

Silicon Motion, Inc.

Mobile Computer Display Controller

Preliminary

Version 11.0

Last Updated 11/29/01

Lynx3DM DataBook

Silicon Motion[®], Inc.

Lynx3DM DataBook

Notice

Silicon Motion[®], Inc. has made best efforts to ensure that the information contained in this document is accurate and reliable. However, the information is subject to change without notice. No responsibility is assumed by Silicon Motion, Inc. for the use of this information, nor for infringements of patents or other rights of third parties.

Copyright Notice

Copyright, 2002 Silicon Motion, Inc. All rights reserved. No part of this publication may be reproduced, photocopied, or transmitted in any form, without the prior written consent of Silicon Motion, Inc. Silicon Motion, Inc. reserves the right to make changes to the product specification without reservation and without notice to our users

Microsoft[®], Windows[®], Windows NT[®], and Direct3D[®] are registered trademarks or trademarks of Microsoft Corporation.

Macrovision[®]: This product incorporates copyright protection technology that is protected by U.S. patents and other intellectual property rights. Use of this copyright protection technology must be authorized by Macrovision, and is intended for home and other limited pay-per-view uses only unless otherwise authorized by Macrovision. Reverse engineering or disassembly is prohibited

Version Number	Date	Note
0.2	6/3/99	<ul style="list-style-type: none"> • Changed External Display Memory Interface & Video Port Interface in Figure 4 on page 5-2 • Changed Register Bits in Figure 8 on page 5-3 • Changed Figure 9 on page 5-2 • Added Figure 18 on page 5-9 (TFT Two Panel Interface Diagram) • PCI Configuration Space Registers Chapter: Added registers (CSR50, CSR51, CSR52, CSR53, CSR54, & CSR58) • Extended SMI Registers: Added registers (CCR7A-CCR7D, FPR4D, FPR4E, MCR76, CRT37, CRT3E, CRT3F, CRT90-CRT9B, CRT9E, CRT9F, CRTA8-CRTAD, CRTA7, SCR1C, SCR1F, SCR10) and Changed registers (CRT3B, CRT3C, FPR49, MCR60, MCR62, MCR76, PHR81, SCR15, SCR16, SCR17) • 2D & Video Registers: Changed Registers (VPR00, VPR04, VPR08, VPR0C, VPR10, VPR14, VPR18, VPR1C, VPR20, VPR24, VPR28, VPR30, VPR38, VPR3C, VPR40, VPR44, VPR54, VPR58) • Changed Figure 57 on page 28-1
0.21	6/11/99	<ul style="list-style-type: none"> • Change to LCD Backend Controller and Nand Tree Testing in Chapter 2 • Change to Colot TFT/DSTN in normal/Virtual Refresh in on page 14-2. • Change in address for registers: CSR50-CSR58 on page 19-8 and 19-9
0.3	6/30/99	<ul style="list-style-type: none"> • Change to registers CSR02, CSR10, CSR2C, CSR2E, CSR40, CSR50, DPR08, DPR1E, CPR00, CPR0C, CPR10, CPR14 • Change to 3D registers DPRA0, DPRBC, DPRC0, DPRC4, DPRCC, DPRD8, DPRE8, DPREC, DPRF4, Texture Base Register, Texture Blending Mode, 3D_Command_Set_0, 3D_Command_Set_1, 3D_Command_Set_2, 3D Test Command, Go register in Vertex, DMA 32-bit Mask, Table of Entry Address, DMA Total Transfer Size of 64-bit Data • Added I/O Port 3C4 Table and I/O Port 3?4 Table in Chapter 18 • Added Appendix D: Programming USR [3:0] pins, Appendix E: Monitor and TV Detect, and Appendix F: CRT Timing Registers Summary • Changed Table 6: Lynx3DM Video Port Interface I/O Configuration page 8-2
0.4	7/15/99	<ul style="list-style-type: none"> • Change to registers CSR2E, MCR76, SCR10 (delete), SCR15, SCR17, SCR1C, SCR1F, PDR21, POP90, CRT39, CRT9F, CRTA7, CSR2C, CSR2E • Added Appendix G: 2D/3D Bus Master DMA Data Stream Format

Version Number	Date	Note
0.5	8/6/99	<ul style="list-style-type: none"> • Change to Pin Description Table: Clock Interface (added SCLK2 to MCKIN/LVDSCLK), Flat Panel Interface (deleted FDA14, SCLK2 from FDATA) • Change to BGA Pin List Table: Added SCLK2 to Pin #L17 and deleted FPSCLK2 from Pin #Y9 • Change to Flat Panel Interface Table: Deletion of FP2_SCLK for FPDATA14 pin, and added LV_SCLK Pin • Change to TFT Two Panel Interface Diagram: Deleted FDATA_[14] and replaced with LVDSCLK • Change to Interface Signals Sleep Mode States Table: Change to Video Port Interface P [15:0] • Change to Power-On Configuration Table: Change to MD[23]
0.6	9/3/99	<ul style="list-style-type: none"> • Change to Figure: 316 BGA Mechanical Dimension. The ball pitch was changed from "c" to "e"
0.7	9/20/99	<ul style="list-style-type: none"> • Change to Power-On Configuration Table: Signal Name MD [32], Enable AGP sideband signals, 0=Disable 1=Enable
0.8	12/10/99	<ul style="list-style-type: none"> • Change to registers: CCR65, FPR4E (renamed LCD2), & CCR69 • Added Lynx3DM Dual Digital LCD Support description in Chapter 9
0.9	1/19/00	<ul style="list-style-type: none"> • Change to Table 5: Power-on-Configuration, Signal Name MD[7:6], MD[14:12] • Change to Register FPR30, bit [6:4] addition
0.95	7/07/00	<ul style="list-style-type: none"> • Updated to include 16 Mbyte configuration.
10.0	4/13/01	<ul style="list-style-type: none"> • Updated display support mode tables. • Changed register MCR62 • Change to Digital DC Specification Table • Added Ordering Information Table • Changed RAMDAC/Clock Synthesizer DC Specifications for CVDD
11	6/4/01	<ul style="list-style-type: none"> • Changed Digital Specifics for ICC • Revised block diagram • Added Thermal Characteristics to Electrical Specification Chapter
12	11/29/01	<ul style="list-style-type: none"> • Changed DC Spec for C_{IN} and C_{OUT} - Electrical Specification Chapter • Updated Memory Mapped Address Diagram

Table of Contents

Chapter 1: Overview	1-1
Overview of Major System Blocks	1-4
Chapter 2: Pins	2-1
Lynx3DM Pin Descriptions	2-1
Lynx3DM NAND Tree Scan Testing	2-17
General Information	2-17
NAND Tree Simulation	2-17
Chapter 3: Initialization	3-1
Lynx3DM Power-On Configurations	3-3
Chapter 4: PCI/AGP Bus Interface	4-1
PCI Configuration Registers	4-1
Chapter 5: Display Memory Interface	5-1
Memory Configuration	5-1
Page Break Look Ahead	5-1
Memory Timing Control	5-1
Chapter 6: Drawing Engine	6-1
Chapter 7: Video Processor	7-1
Chapter 8: Zoom Video Port and Video Capture Unit	8-1
Zoom Video Port	8-1
Video Capture Unit	8-2
Functional Description	8-3
Theory of Operation	8-4
Chapter 9: Flat Panel Interface	9-1
Lynx3DM Flat Panel Enhancements	9-1
Lynx3DM Flat Panel Enhancements	9-1
Lynx3DM Graphics/Text Expansion Information	9-1
Introduction	9-1
Horizontal Expansion for Text and Graphics	9-1
Vertical Expansion for Text and Graphics	9-2
LCD Dithering Engine	9-3
Flat Panel Power ON/OFF Sequencing	9-3
Lynx3DM Dual Digital LCD Support	9-4
Lynx3DM Flat Panel Interface Connections	9-4
LVDS Chipset Interface	9-12
Chapter 10: Miscellaneous Functions	10-1
Video BIOS ROM Interface	10-1
VESA DPMS Interface	10-2
I2C Bus or VESA DDC2B Interface	10-2
Chapter 11: Clock Synthesizers	11-1
Chapter 12: Multimedia RAMDAC	12-1
LCD Backend RAM (RAM1)	12-1
Chapter 13: Signature Analyzer	13-1
Chapter 14: Power Management	14-1
ACPI	14-1
Adaptive Power Management	14-1
Dynamic Control of Functional Blocks	14-1
Dynamic Clock Control and Virtual Refresh	14-2
Standard Power Management	14-2

Standby Mode	14-2
Power Saving In Standby Mode	14-3
Sleep Mode	14-3
Activity Detection	14-4
Power-down Sleep Mode States	14-4
Chapter 15: Motion Compensation Specification	15-1
Overview	15-1
Data Flow and External System Responsibilities	15-1
MC Top Level Architecture	15-1
MC Instruction Format and Operation	15-3
Chapter 16: 3D Engine	16-1
IEEE 754 Floating Point Setup Engine	16-1
Triangle Engine	16-2
Z Engine	16-2
Texture Engine	16-3
Pixel Engine	16-4
Modulation/Addition Unit	16-4
Fog Blending Unit	16-4
Chroma-Key Test Unit	16-4
Alpha Blending Unit	16-4
Dithering Unit	16-4
Chapter 17: TV Encoder	17-1
Function Descriptions	17-3
Macrovision Antitaping process	17-3
Closed Captioning	17-4
Video data output and Over-sampling	17-5
Synchronization	17-5
Sub-carrier Generation	17-5
Parallel bus I/F	17-5
Chapter 18: Register Overview & Usage	18-1
PCI Configuration Registers	18-1
Memory Mapped I/O Registers	18-1
Memory Mapped Registers	18-1
Chapter 19: PCI Configuration Space Registers	19-1
PCI Configuration Space Registers	19-2
Extended SMI Registers	19-10
Chapter 20: Standard VGA Registers	20-1
Standard VGA Registers	20-4
General Registers	20-4
Sequencer Register	20-6
CRTC Controller Registers	20-9
Graphics Controller Registers	20-21
Attribute Controller Registers	20-26
RAMDAC Registers	20-30
Chapter 21: Extended SMI Registers	21-1
Extended SMI Registers	21-6
System Control Registers	21-6
Power Down Control Registers	21-13
Flat Panel Registers	21-18
Memory Control Registers	21-38
Clock Control Registers	21-41
General Purpose Registers	21-49
Pop-up Icon and Hardware Cursor Registers	21-51
Pop-up Icon Registers	21-52

Hardware Cursor Registers	21-55
Extended CRT Control Registers	21-57
Shadow VGA Registers	21-67
Automatic Lock/Unlock Scheme for Shadow Registers	21-67
Chapter 22: 2D & Video Registers	22-1
Drawing Engine Control Registers	22-4
Video Processor Control Registers	22-20
Capture Processor Control Registers	22-45
Chapter 23: Motion Comp Video Registers	23-1
Motion Comp Bus Master CMD Control Registers	23-2
Chapter 24: PCI Bus Master Control Registers	24-1
Motion Compensation ICMD Control Registers	24-2
Motion Compensation IDCT Control Registers	24-3
Host Master Control Registers	24-5
Texture 3D Bus Master Control Registers	24-9
Chapter 25: 3D Registers	25-1
2D3D DMA Registers	25-16
Chapter 26: TV Encoder Registers	26-1
Register Descriptions	26-2
Common Register	26-2
Closed Captioning Registers	26-2
Chapter 27: Electrical Specifications	27-1
Absolute Maximum Ratings	27-1
DC Specifications	27-1
AC Specifications	27-2
AC Timing Specifications	27-3
PCI Bus Cycles	27-4
AGP BUS Cycles	27-5
Synchronous DRAM (SDRAM) and SGRAM Cycles	27-7
Flat Panel Interface Cycle Timing	27-8
Chapter 28: Mechanical Dimensions	28-1
Chapter 29: Index	29-1
Appendix A: Video Modes	A-1
Standard IBM Compatible VGA Modes	A-1
VESA Super VGA Modes	A-2
Low Resolution Modes	A-2
640 by 480 Resolution Modes	A-3
800 by 600 Resolution Modes	A-3
1024 by 768 Resolution Modes	A-4
1280 by 1024 Resolution Modes	A-4
Appendix B: Popup Icon Consideration	B-1
Introduction	B-1
Popup Icon	B-1
Icon Pattern Memory Location	B-1
Icon Pattern	B-2
Icon Control	B-2
Video BIOS Function Call	B-2
Appendix C: SMI Handler Programming Consideration	C-1
Introduction	C-1
Background	C-1
System BIOS Consideration	C-1
Int10 Vector Entry	C-1
Alternate INT10 Entry	C-1
Appendix D: Programming USR [3:0] Pins	D-1

Application Notes for control of USR [3:0] Pins.	D-1
Appendix E: Monitor & TV Detect	E-1
CRT Monitor Detect	E-1
TV Detect	E-1
Appendix F: CRT Timing Register Summary	F-1
CRT Timing Register Summary	F-1
Appendix G: 2D/3D Bus Master DMA Data Stream Format	G-1
2D3D Bus Master - DMA Data Stream Format.	G-1

List of Figures

Figure 1:	System Block Diagram for Lynx3DM	1-2
Figure 2:	Top Level 3D Flow Diagram	1-5
Figure 3:	SM721 Pin Diagram for 316 BGA Package	2-6
Figure 4:	NAND Tree Connection	2-17
Figure 5:	NAND Tree Simulation Timing Diagram	2-17
Figure 6:	SGRAM Power-Up and Initialization Sequence	3-1
Figure 7:	Lynx3DM Video BIOS Initialization Flow	3-2
Figure 8:	External 4MB SGRAM Configuration (2x512Kx32)	5-2
Figure 9:	Video Processor Block Diagram	7-1
Figure 10:	Video Encoder Interface via Video Port	8-1
Figure 11:	Video Capture Block Diagram	8-3
Figure 12:	Video Capture Data Flow	8-4
Figure 13:	Capture Buffer Structure in Interlaced Mode	8-7
Figure 14:	DDA Expansion Algorithm	9-2
Figure 15:	TFT (Single Pixel/Clock) Interface Diagram	9-8
Figure 16:	TFT Panel (2 pixels/clock) Interface Diagram	9-8
Figure 17:	TFT Two Panel Interface Diagram	9-9
Figure 18:	16-bit DSTN Interface Configuration	9-10
Figure 19:	24-bit Dual Color STN Interface Diagram	9-10
Figure 20:	Panel Power On Sequencing Timing Diagram	9-11
Figure 21:	Panel Power Off Sequencing Timing Diagram	9-11
Figure 22:	LVDS Interface with TFT LCD Panel	9-12
Figure 23:	LVDS Interface with DSTN LCD Panel	9-12
Figure 24:	36-bit (18x2 bit) TFT Interface Diagram	9-13
Figure 25:	PanelLink Interface with TFT LCD Panel	9-14
Figure 26:	PanelLink Interface with DSTN LCD Panel	9-14
Figure 27:	Video BIOS ROM Configuration Interface	10-1
Figure 28:	Lynx3DM I2C Bus Protocol Flow Chart	10-3
Figure 29:	Clocks Generator Block Diagram	11-1
Figure 30:	Lynx3DM RAMDAC Block Diagram	12-1
Figure 31:	Signature Analyzer Block Diagram	13-1
Figure 32:	MC Top Level Architecture	15-2
Figure 33:	Control Block Diagram	15-2
Figure 34:	QLF Block Diagram	15-3
Figure 35:	End Stream Instruction	15-4
Figure 36:	MC Instruction Format	15-4
Figure 37:	3D Engine Block Diagram	16-1
Figure 38:	Setup Engine Block Diagram	16-2
Figure 39:	Triangle engine block diagram	16-2
Figure 40:	Z Engine Block Diagram	16-3
Figure 41:	Texture Engine Block Diagram	16-3
Figure 42:	Pixel pipeline block diagram	16-4
Figure 43:	TV Encoder Block Diagram	17-2
Figure 44:	I/O Port 3C4	18-2
Figure 45:	I/O Port 3?4	18-2
Figure 46:	Memory Mapped Address Diagram	18-3
Figure 47:	Memory Mapped Address Diagram	22-4
Figure 48:	Power-on Reset and Reset Configuration Timing	27-3

Figure 49: PCI Bus Timing Diagram27-4
Figure 50: AGP Bus Timing Diagram27-5
Figure 51: AGP 2X Read Request with Return Data (4Qw)27-6
Figure 52: SDRAM/SGRAM Read and Write Cycles27-7
Figure 53: TFT Interface Timing27-8
Figure 54: DSTN Interface (Clock and Data) Timing27-9
Figure 55: DSTN Interface (Control and Clock) Timing27-9
Figure 56: 316 BGA Mechanical Dimensions28-1
Figure 57: Hardware Cursor and Popup Icon Memory Location B-1

List of Tables

Table 1:	Lynx3DM (4MB): Display Support Modes	1-9
Table 2:	Lynx3DM (8MB): Display Support Modes	1-11
Table 3:	Lynx3DM (16MB): Display Support Modes	1-13
Table 4:	Pin Description	2-2
Table 5:	Numerical SM721 BGA Pin List	2-7
Table 6:	Lynx3DM VCC and GROUND Connections	2-15
Table 7:	NAND Tree Scan Test Order	2-18
Table 8:	Power-On Configurations	3-3
Table 9:	Lynx3DM Video Port Interface I/O Compliance	8-2
Table 10:	Bit Setting Summary for Video Capture	8-5
Table 11:	Flat Panel Interface Pins listing for color DSTN and color TFT LCD	9-4
Table 12:	LVDS Transmitter Pin Mapping for TFT Interface	9-15
Table 13:	LVDS Transmitter Pin Mapping for DSTN Interface	9-16
Table 14:	PanelLink Transmitter Pin Mapping for TFT Interface	9-17
Table 15:	PanelLink Transmitter Pin Mapping for DSTN Interface	9-18
Table 16:	DPMS Summary	10-2
Table 17:	Recommended VNR and VDR Values for Common VCLK Settings	11-2
Table 18:	Interface Signals Sleep Mode States	14-4
Table 19:	Instruction Flags and Parameters	15-4
Table 20:	TV Encoder Block Interface Description	17-2
Table 21:	TV Encoder Sampling Rates	17-3
Table 22:	Closed Captioning Lines	17-4
Table 23:	Closed Captioning Odd Field Output Data	17-5
Table 24:	Closed Captioning Even Field Output Data	17-5
Table 25:	PCI Configuration Registers Quick Reference	19-1
Table 26:	Standard VGA Registers Quick Reference	20-1
Table 27:	Extended SMI Registers Quick Reference	21-1
Table 28:	Memory Mapped Registers Quick Reference	22-1
Table 29:	Motion Comp Video Registers Quick Reference	23-1
Table 30:	PCI Bus Master Control Registers Quick Reference	24-1
Table 31:	Summary of Registers	25-1
Table 32:	3D Registers Quick Reference	25-4
Table 33:	TV Encoder Registers Quick Reference	26-1
Table 34:	Absolute Maximum Ratings	27-1
Table 35:	Digital DC Specification	27-1
Table 36:	RAMDAC Characteristics	27-2
Table 37:	RAMDAC/Clock Synthesizer DC Specifications	27-2
Table 38:	RAMDAC AC Specifications	27-2
Table 39:	Power-on Reset and Configuration Reset Timing	27-3
Table 40:	PCI Bus Timing (33 MHz)	27-4
Table 41:	AGP 1X mode BUS Timing	27-5
Table 42:	AGP 2X Timing Parameters	27-6
Table 43:	SDRAM/SGRAM Memory Read Timing	27-7
Table 44:	Color TFT Interface Timing	27-8
Table 45:	Color DSTN Interface Timing	27-9
Table 46:	Ordering Information	28-2
Table 47:	Standard IBM Compatible VGA Modes	A-1
Table 48:	VESA Super VGA Modes	A-2

Table 49:	Low Resolution Modes	A-2
Table 50:	640 x 480 Extended Modes	A-3
Table 51:	800x600 Extended Modes	A-3
Table 52:	1024x768 Extended Modes	A-4
Table 53:	1280x1024 Extended Modes	A-4
Table 54:	CRT Timing and LCD Shadow Register Summary	F-1

Chapter 1: Overview

The Lynx3DM is a power managed, desktop equivalent display controller for notebook PCs. This device delivers full featured 3D, a unique memory architecture designed to enhance 3D/2D performance, enhanced multi-display capabilities, and Motion Compensation for DVD.

The Lynx3DM incorporates an IEEE Floating Point Setup engine as well as a full featured 3D rendering engine. The setup engine is designed to balance with the triangle delivery capabilities of high end notebook processors. The rendering engine supports key features such as Mip Mapping, Alpha Blend, Anti-Aliasing, Specular Highlights and Fog.

The Lynx3DM integrates 4MB, 8MB or 16MB of video memory. The Lynx3DM employs a unique dual memory controller architecture which allows the integrated memory bus and external memory bus to run in parallel. This allows up to a 128-bit memory interface and over 1.6GB/s of memory bandwidth.

Lynx3DM continues to support all the Dual Application/Dual View capabilities of its predecessor, LynxE. In addition, Lynx3DM can drive two independent digital displays (dual-digital), as well as simultaneously drive LCD, CRT and TV displays (multiview). Support for all of these features is provided under Windows 95, Windows 98, Windows Me, Windows NT 4.0, and Windows 2000.

A robust 128-bit Drawing Engine provides no compromise 2D performance. The Drawing Engine supports 3 ROPs, BitBLT, transparent BLT, pattern BLT, color expansion, and line draw. The Host Interface Unit allows support for AGP and PCI. Support for all ACPI power states is provided. A high quality TV encoder, VGA Core, LCD Backend Controller and 200 MHz RAMDAC are incorporated as well.

The Lynx3DM's Motion Compensation block, Video Processor block, and Video Capture Unit provide superior video quality for real-time video playback and capture. When combined with high end notebook CPUs, the Motion Compensation block allows full frame playback of DVD video content without the need for additional hardware. The Video Processor supports multiple independent full screen, full motion video windows with overlay. Each motion video window uses hardware YUV-to-RGB conversion, scaling, and color interpolation. When combined with multi-view capabilities of the chip, these independent video streams can be output to each of two display devices and bilinear scaled to support applications such as full screen display of local and remote images for video conferencing.

Lynx3DM is designed with 0.25m, 4LM, 2.5V CMOS process technology. A hierarchical layout approach provides enhanced internal timing control. In addition to built-in test modes and a signature analyzer, the Lynx3DM incorporates a 20 bit test bus which can be used to simultaneously monitor internal signals through the Zoom Video (ZV) Port Interface. The capability can be used to increase fault coverage, and to reduce silicon validation and debugging time. The Lynx3DM is available in a 316 pin BGA packages.

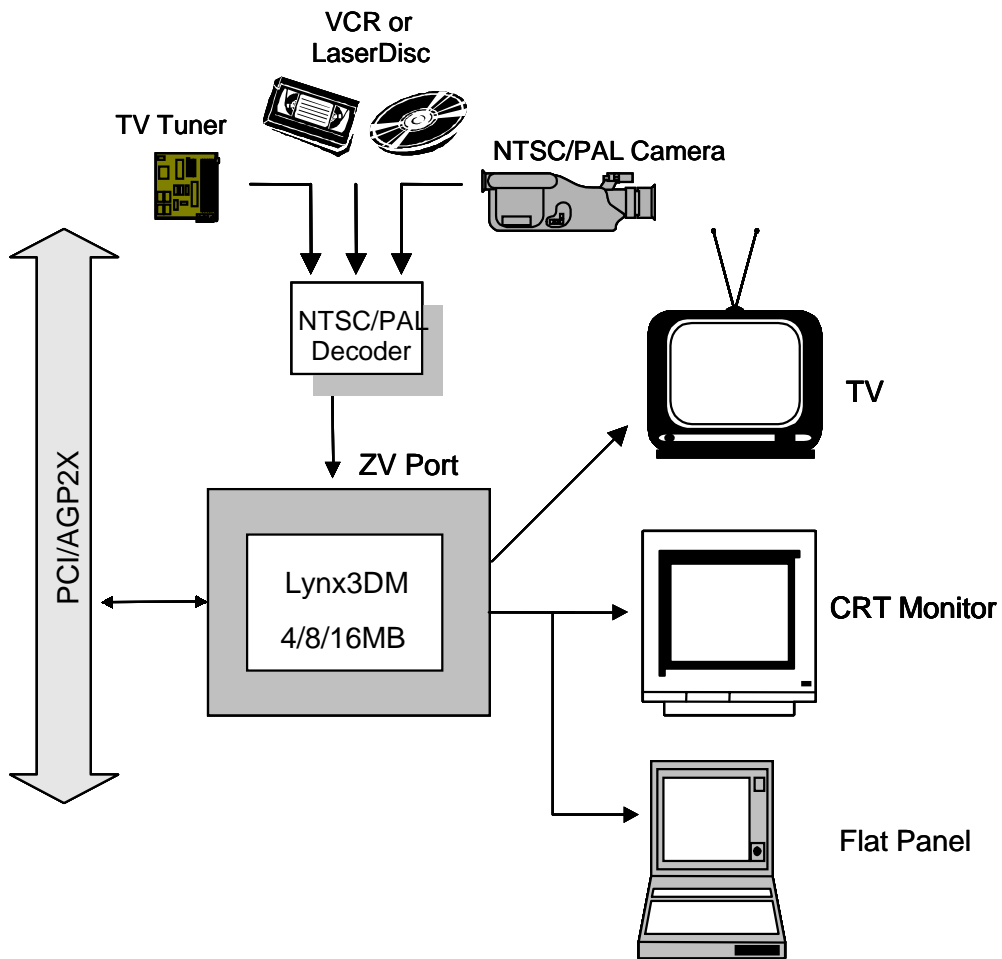

Figure 1: System Block Diagram for Lynx3DM

Features	Benefits
High performance, power managed 3D	Desktop level 3D performance within the power budget of a notebook system
Motion Compensation	Allows full frame playback of DVD content in software
Multi-Display support under Microsoft Windows 95, Windows NT, Windows 98 and Windows Me with one device	<ul style="list-style-type: none"> • Applications available at the same time across multiple display devices • Single chip implementation ideal for mobile systems
SMI Dual View support under Microsoft Windows 95, Windows NT, Windows 98 and Windows Me	Any rectangular portion of primary display can be zoomed up for display on multiple secondary displays
Dual-Digital support	Independent display support for external digital LCD monitor or LCD projector
Adaptive Power Management <ul style="list-style-type: none"> • Dynamic functional block shut-down, clock control 	<ul style="list-style-type: none"> • Reduce average power consumption when in operation mode
Multiple independent hardware video windows	<ul style="list-style-type: none"> • Independent full screen, motion video for separate displays. • Complete dual view support for video
128-bit, single clock cycle Drawing Engine	No compromise 2D graphics performance for mobile systems
High performance memory interface	Delivers over 1.6GB/s bandwidth to support 3D graphics, DVD
AGP 2X sideband and PCI 2.1 support	Provides interface capability for today's most popular PC graphics busses
DSTN and TFT panel support up to 1600x1200	Supports all panel requirements for mobile systems
Integrated TV Encoder with Macrovision	Graphics/video display on TV with no external support logic
Zoom Video Port	Provides support for camera, TV tuner input, or output to VCR
Hardware support for LCD landscape/portrait rotation	Portrait view for desktop publishing, word processing applications
PC99 Compliant, ACPI Compliant	Meets WHQL certification requirements
SW support for Microsoft Windows 95, Microsoft Windows NT 4.0, Microsoft Windows 98, Windows Me, Windows 2000, and OS/2	Complete OS software support

Microsoft, Windows, Windows NT, and Direct3D are registered trademarks or trademarks of Microsoft Corporation.

Regarding Macrovision: This product incorporates copyright protection technology that is protected by U.S. patents and other intellectual property rights. Use of this copyright protection technology must be authorized by Macrovision, and is intended for home and other limited pay-per-view uses only unless otherwise authorized by Macrovision. Reverse engineering or disassembly is prohibited.

Overview of Major System Blocks

The Lynx3DM consists of a logic block which interfaces to a 4MB, 8MB or 16MB block of integrated memory. The integrated memory supports single clock cycle transfers up to 100MHz. Peak memory bandwidth for the integrated 128-bit memory bus is over 1.6GB/s.

The logic within the Lynx3DM consists of 11 functional blocks: PCI Interface, Host Interface (HIF), Memory Controller, Drawing Engine, Power Down Control Unit, Video Processor, Video Capture Module, LCD Backend Controller, VGA Core, PLL Module, and RAMDAC. A summary of each of the functional blocks, along with important features follows:

AGP/PCI Interface and HIF

Lynx3DM's PCI Host Interface Unit supports burst read, burst write, and bus master mode with DMA. The Host Interface Unit decodes I/O read, I/O write, memory read, memory write, memory mapped access, 2D/3D Drawing Engine access, VGA access, and others. The unit also supports Little-Endian and Big-Endian format, and 8-bit ROM decode for on board video BIOS ROM. A dual aperture feature is designed to support VGA modes and non-VGA modes. In addition, a special VGA aperture function is added to allow 64-bit memory access in VGA modes.

Lynx3DM has an internal HIF (Host Interface) bus which is designed to transfer data between PCI Host Interface Unit and other functional blocks. The PCI Host Interface Unit controls the HIF bus protocol to effectively deliver PCI I/O and memory cycles to each functional block.

Lynx3DM supports 2X with sideband Accelerated Graphics Port (AGP). The AGP interface provides a high bandwidth, low latency connection to the system memory; therefore, it can increase the graphics performance for 2D and 3D applications.

Key Feature Summary:

- AGP 2X sideband support
- 33 MHz PCI Master/Slave interface
- PCI 2.1 compliant
- Dual aperture feature for concurrent VGA and video/drawing engine access

Memory Controller

Independent control is provided for the 4/8/16MB block of integrated memory. Page Break Look Ahead support assures a memory cycle is not broken if there is a change of memory bus agent within the same memory page. Programmable memory arbitration allows memory interface usage to be fully optimized - priority and round robin arbitration is supported. The block write function for SGRAM is supported.

Key Feature Summary:

- Independent memory interface control
- Up to 128-bit memory interface
- Over 1.6GB/s memory bandwidth

Drawing Engine

The Lynx3DM's 128-bit Drawing Engine is designed to accelerate 2D and 3D through APIs such as Direct Draw and Direct3D. The engine pipeline runs at a single clock per cycle at speeds of 100MHz+. The engine supports key GUI functions such as 3 operand ALU with 256 raster operations, pattern BLT, color expansion, trapezoid fill, and line draw. Direct3D rendering acceleration is provided by support for features such as arithmetic stretching, source transparent BLT, and double buffering.

Key Feature Summary:

- 100MHz single clock/cycle engine
- Designed to accelerate DirectDraw and Direct3D

3D Engine

The Lynx3DM incorporates an IEEE Floating Point Setup engine as well as a full featured 3D rendering engine. The diagram below illustrates a top level diagram of the Lynx3DM setup and rendering pipeline.

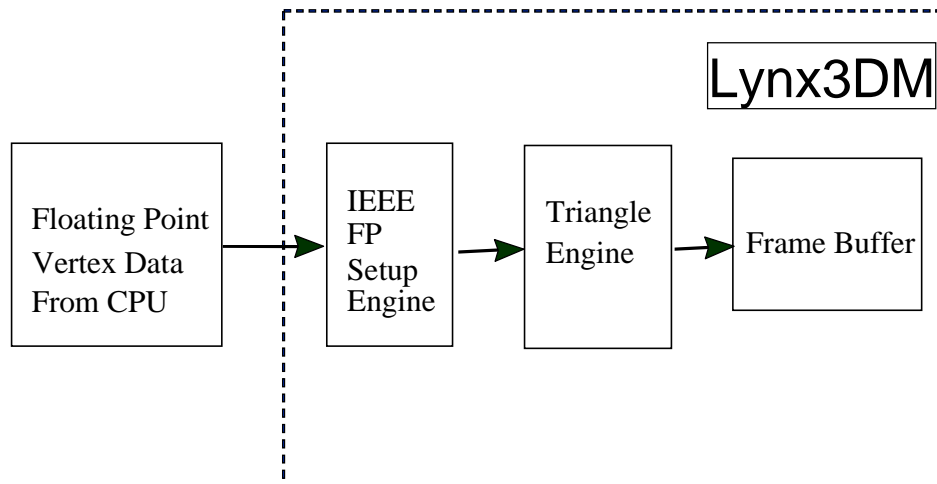

Figure 2: Top Level 3D Flow Diagram

The setup engine is designed to balance with the triangle delivery capabilities of high-end notebook processors. The setup engine performs single precision floating point operations to calculate slope parameters (x, y, z; color - RGB, alpha; texture - s, t, perspective) from the triangle vertex data delivered from the CPU. The slope information is derived with sub-pixel accuracy to eliminate misalignment. The rendering engine utilizes the slope information to render the defined triangle to the screen. The rendering engine supports a full set of 3D rendering features. A representative list of features is provided in the Key Feature Summary below.

Key Feature Summary:

- IEEE Floating Point Setup Engine
- Complete 3D Rendering Engine set:
 - Bi-linear and tri-linear filtering
 - Mip Mapping
 - Vertex and global fog
 - Source and destination alpha blend
 - Specular highlights
 - Edge anti-aliasing
 - Z-buffering
 - Gouraud shading
 - Mirrored textures
 - Texture decompression

Motion Compensation Engine

The Motion Compensation Engine offloads the motion compensation portion of the MPEG-2 decode process. This block can reduce CPU overhead requirements for MPEG-2 decode by 20%-40%, depending on CPU type and MPEG-2 data rate. To insure proper handling of MPEG-2 video data streams, the Lynx3DM implements a separate bus master control mechanism for motion compensation command and IDCT data. This approach allows for a dedicated pipeline through

which the motion compensation command and IDCT data can be transferred to the Motion Compensation Engine for processing.

The motion compensation block provides full sub-picture support as well. Both 2-bit/pixel formats and 8-bit/pixel formats (4-bit color data, 4-bit alpha data) are supported.

Key Feature Summary:

- Offloads motion compensation portion of MPEG-2 decode process from CPU
- Separate bus master control for motion compensation command and IDCT data
- Sub-picture support
 - 2-bit/pixel format
 - 8-bit/pixel format

Digital TV-Encoder

The TV Encoder is an NTSC/PAL Composite Video/S-video Encoder. It receives RGB inputs and converts to digital video signals based on CCIR 624 format.

The input video signal of the TV Encoder is RGB 8 bit each. The sampling rate is corresponding to CCIR 601, Square pixel and 4Fsc.

The output video signals of the TV Encoder are Composite Video signal and S-video signals of 10-bit each. These output signals are over-sampled by a double frequency clock called CLKX2. This feature helps for simplify external analog filtering.

The TV Encoder video timing is controlled by vertical sync and the horizontal sync input signals. The blank signal input is optional. If the blank signal input signal is pulled up, internal blanking control will be performed.

Macrovision 7.1.21 and closed captioning functions are included.

Key Feature Summary:

- NTSC/PAL interlace mode digital video encoder
- Composite Video and S-Video digital output
- CCIR 601, Square pixel and 4Fsc (NTSC only) resolution RGB input
- Interlace mode operation
- 2x over-sampling data output to simplify external analog filtering
- Macrovision function (version 7.1.21)
- Closed captioning function

Power Down Control Unit

The Power Down Control unit provides Dynamic Power Management for all functional blocks within the Lynx3DM. Dynamic Power Management is made possible by individual clocking control to each of the functional blocks within Lynx3DM. Each clock to a given functional block is skew matched to maintain synchronization between blocks. The functional blocks can then be turned on/off "on the fly" as needed. Power savings under fully operational conditions is maximized, yet the process completely transparent to the user.

Control for Virtual Refresh is provided through the Power Down Control unit as well. Through Virtual Refresh, LCD panel timing may be driven from a fully independent PLL. VCLK can be significantly reduced, while retaining full graphics performance. The result is significant power savings for LCD only configurations.

Finally, the Power Down Control unit generates power down sequencing for Standby and Suspend modes. Internal auto-standby and system standby implementations are supported.

Under sleep mode, options for memory refresh type and use of internal PLL/external clock for memory refresh clock are provided. Activity detection is supported for resuming from Standby or Suspend modes.

Key Feature Summary:

- Dynamic Power Management
- Virtual Refresh
- Standby and Suspend model support
- ACPI, DPMS, APM compliant

Video Processor

The Video Processor module manages video playback to an LCD, CRT, or TV display. Independent video sources can be scaled up and displayed full screen different display devices - ideal for videoconferencing applications. The Video Processor module supports, bi-linear scaling, YUV to RGB color space conversion, color key, and overlay of graphics over video. The Video Processor module also supports flicker reduction and adjustable overscan/underscan for TV display.

Key Feature Summary:

- Multiple video windows in HW
- Independent video sources on different displays
- Bi-linear scaling
- Flicker filter and underscan for TV display

Video Capture

The Video Capture module processes incoming video data from the Zoom Video Port and sends the data to the local video frame buffer. From there, the data may be displayed, as well as bus mastered out for storage on a hard drive. Incoming data from the Zoom Video port can be interlaced or non-interlace and in YUV or RGB format. The data can be cropped, horizontally filtered (2,3,or 4-tap), and shrunk to ¼ size. Single buffer as well as double buffer capture is supported.

Key Feature Summary:

- Support for Zoom Video Port interface
- Crop, filter, shrink support

LCD Backend Controller

The LCD Backend Controller module manages data flow and generates timing to the selected LCD display. The module provides support for 9, 12, 18, 24, 36, 48, 2x18, 2x24 bit TFT and DSTN panels up to SXGA+ resolution. The backend controller contains a color encoder, dithering engines for TFT and DSTN panels, frame accelerator, and a Virtual Refresh timing generation block. Each of the blocks within the LCD Backend controller module can be powered down if not in use.

Key Feature Summary:

- TFT and DSTN support up to SXGA+
- Timing generation for Virtual Refresh

Popup Icon

The Lynx3DM support 64x64 popup icon which can be zoomed up by 2 to become 128x128 popup icon. The popup icon can be programmed to anywhere on the screen display. In addition, the popup icon has transparency support.

Key Feature Summary:

- Popup icon location flexible
- Transparency color support

VGA Core

The Lynx3DM has a high performance 32-bit VGA core which is 100% IBM VGA compatible. In addition to standard VGA functions, the Lynx3DM's VGA core module generates LCD timing, performs LCD screen auto-centering and expansion, generates TV timing, and provides Hardware Cursor control.

Key Feature Summary:

- 100% IBM VGA compatible

PLL Module

The PLL module provides three separate PLLs for MCLK, VCLK, and Virtual Refresh clock to drive LCD panel timing. A 14.318MHz base clock is used to drive TV timing. This allows for completely independent timing for LCD/CRT or LCD/TV under dual application or dual view. For instance, the LCD panel can be driven at 60Hz while CRT refresh is 85Hz.

Key Feature Summary:

- Separate PLL for LCD panel timing

RAMDAC

The integrated RAMDAC supports pixel clock frequencies up to 200MHz. Anti-sparkle logic is provided for read/writes to the palette. An internal band gap voltage reference saves need for external RC components.

Table 1: Lynx3DM (4MB): Display Support Modes

CRT Only				
Display Resolution	Refresh (Hz)	Color Depth		
		8 bpp	16 bpp	24 bpp
640x480	60	x	x	x
	75	x	x	x
	85	x	x	x
	100	x	x	x
800x600	60	x	x	x
	75	x	x	x
	85	x	x	x
	100	x	x	x
1024x768	60	x	x	x
	75	x	x	x
	85	x	x	x
	100	x	x	-
1280x1024	60	x	x	x
	75	x	x	-
	85	x	x	-
	100	x	x	-

LCD/Simultaneous Mode				
Display Resolution	Refresh (Hz)	Color Depth		
		8 bpp	16 bpp	24 bpp
640x480	60	x	x	x
800x600	60	x	x	x
1024x768	60	x	x	x
1280x1024	60	x	x	x

Dual Display Mode				
Display 1 (D1)	Display 2 (D2)	Color Depth (Max Color Depth Display 2 bpp)		
		when D1 is 8 bpp	when D1 is 16 bpp	when D1¹ is 24 bpp
640x480	640x480	24 (D2)	24 (D2)	-
	800x600	24	24	-
	1024x768	24	24	-
	1280x1024	16	16	-
800x600	640x480	24	24	-
	800x600	24	24	-
	1024x768	24	24	-
	1280x1024	16	16	-

1024x768	640x480	24	24	-
	800x600	24	24	-
	1024x768	24	24	-
	1280x1024	16	16	-

¹Max color depth for display 1, 16bpp under dual display

Table 2: Lynx3DM (8MB): Display Support Modes

CRT Only				
Display Resolution	Refresh (Hz)	Color Depth		
		8 bpp	16 bpp	24 bpp
640x480	60	x	x	x
	75	x	x	x
	85	x	x	x
	100	x	x	x
800x600	60	x	x	x
	75	x	x	x
	85	x	x	x
	100		x	x
1024x768	60	x	x	x
	75	x	x	x
	85	x	x	x
	100	x	x	x
1280x1024	60	x	x	x
	75	x	x	x
	85	x	x	x
	100	x	x	x

LCD/Simultaneous Mode				
Display Resolution	Refresh (Hz)	Color Depth		
		8 bpp	16 bpp	24 bpp
640x480	60	x	x	x
800x600	60	x	x	x
1024x768	60	x	x	x
1280x1024	60	x	x	-

Dual Display Mode				
Display 1 (D1)	Display 2 (D2)	Color Depth (Max Color Depth Display 2 bpp)		
		when D1 is 8 bpp	when D1 is 16 bpp	when D1¹ is 24 bpp
640x480	640x480	24 (D2)	24 (D2)	-
	800x600	24	24	-
	1024x768	24	24	-
	1280x1024	24	24	-
800x600	640x480	24	24	-
	800x600	24	24	-
	1024x768	24	24	-
	1280x1024	24	24	-

1024x768	640x480	24	24	-
	800x600	24	24	-
	1024x768	24	24	-
	1280x1024	24	24	-

¹Max color depth for display 1, 16bpp under dual display

Table 3: Lynx3DM (16MB): Display Support Modes

CRT Only				
Display Resolution	Refresh (Hz)	Color Depth		
		8 bpp	16 bpp	24 bpp
640x480	60	x	x	x
	75	x	x	x
	85	x	x	x
	100	x	x	x
800x600	60	x	x	x
	75	x	x	x
	85	x	x	x
	100	x	x	x
1024x768	60	x	x	x
	75	x	x	x
	85	x	x	x
	100	x	x	x
1280x1024	60	x	x	x
	75	x	x	x
	85	x	x	x
	100	x	x	x

LCD/Simultaneous Mode				
Display Resolution	Refresh (Hz)	Color Depth		
		8 bpp	16 bpp	24 bpp
640x480	60	x	x	x
800x600	60	x	x	x
1024x768	60	x	x	x
1280x1024	60	x	x	x

Dual Display Mode				
Display 1 (D1)	Display 2 (D2)	Color Depth (Max Color Depth Display 2 bpp)		
		when D1 is 8 bpp	when D1 is 16 bpp	when D1¹ is 24 bpp
640x480	640x480	24 (D2)	24 (D2)	-
	800x600	24	24	-
	1024x768	24	24	-
	1280x1024	24	24	-
800x600	640x480	24	24	-
	800x600	24	24	-
	1024x768	24	24	-
	1280x1024	24	24	-

1024x768	640x480	24	24	-
	800x600	24	24	-
	1024x768	24	24	-
	1280x1024	24	24	-

¹Max color depth for display 1, 16bpp under dual display

Chapter 2: Pins

The Lynx3DM is provided in a 316 BGA package.

Figure 3 illustrates the pinout diagram for SM721 316 BGA package. Figure 56 illustrate the mechanical dimensions of the BGA package.

Lynx3DM Pin Descriptions

The following table, Table 4, provides brief description of each BGA ball of the Lynx3DM. Signal names with ~ preceding are active "LOW" signals, whereas signal names without ~ preceding are active "HIGH" signals. Also, the following abbreviations are used for Pin Type.

Table 5 outlines the numerical SM721 BGA pins.

I - INPUT SIGNAL
O - Output Signal
I/O - Input or Output Signal

*Note: All Outputs and I/O signals are tri-stated. Internal pull-up for I/O pad are all 100K Ω resistor. Internal pull-down for I/O pad are all 100K Ω resistor.

Table 4: Pin Description

Signal Name	Type	Pull-up/ Pull-Down	IOL (mA)	Max. Load (pF)	Description
Host Interface (PCI or AGP)					
AD [31:0]	I/O		TBD	120	Multiplexed Address and Data Bus. A bus transaction consists of an address cycle followed by one or more data cycles.
C/ ~BE [3:0]	I/O		TBD	120	Bus Command and Byte Enables. These signals carry the bus command during the address cycle and byte enable during data cycles.
PAR	I/O		TBD	120	Parity. Lynx3DM asserts this signal to verify even parity across AD [31:0] and C/~BE [3:0].
~FRAME	I/O		TBD	120	Cycle Frame. Lynx3DM asserts this signal to indicate the beginning and duration of a bus transaction. It is de-asserted during the final data cycle of a bus transaction.
~TRDY	I/O		TBD	120	Target Ready. A bus data cycle is completed when both ~IRDY and ~TRDY are asserted on the same cycle.
~IRDY	I/O		TBD	120	Initiator Ready. A bus data cycle is completed when both ~IRDY and ~TRDY are asserted on the same cycle.
~STOP	I/O		TBD	120	Stop. Lynx3DM asserts this signal to indicate that the current target is requesting the master to stop current transaction.
~DEVSEL	I/O		TBD	120	Device Select. Lynx3DM asserts this signal when it decodes its addresses as the target of the current transaction.
IDSEL	I				ID Select. This input is used during PCI configuration read/write cycles.
CLK	I				System Clock, 33MHz. for PCI and 66MHz for AGP
~RST	I				System Reset. Lynx3DM asserts this signal to force registers and state machines to initial default values
~REQ	O		TBD	120	Bus Request (bus master mode)
~GNT	I				Bus Grant (bus master mode)
~INTA	O		TBD	120	Interrupt
PME#	O		TBD	120	Power management event signals
~PIPE	O		TBD	120	Pipe signal. Initiates pipelined AGP request. Signal indicates beginning and duration of pipelined AGP access.
~RBF	O		TBD	120	Read Buffer Full. Indicates if graphics device can accept previously low priority read data
AD_STB[1:0]	I/O		TBD	120	Address strobes 1, 0 for 2X transfer support
ST[2:0]	I				Status bus for AGP support
SBA[7:0]	O		TBD	120	Sideband address bits 7-0
SB_STB	O		TBD	120	Sideband strobe
~AGP_BUSY	O		TBD	120	Power management signal for AGP bus.
~STP_AGP	I				Power management signal for AGP bus.
Power Down Interface					

Signal Name	Type	Pull-up/ Pull-Down	IOL (mA)	Max. Load (pF)	Description
~PDOWN	I	pull-up			Power down mode enable
~CLKRUN/ ACTIVITY	O	pull-up	TBD	60	~CLKRUN or Lynx3DM Memory and I/O activity detection depending on SCR18 [7] 0 = select ~CLKRUN 1 = select ACTIVITY
<i>Clock Interface</i>					
REFCLK	I	pull-up			32KHz refresh clock source for power down
PALCLK	I	pull-up			27MHz clock source for PAL TV
CKIN	I	pull-up			14.318MHz clock (~EXCKEN = 1) or Video Clock (~EXCKEN = 0)
MCKIN/ LVDSCLK	I/O	pull-up	TBD	60	Memory Clock In (~EXCKEN = 0) LVDSCLK Out (~EXCKEN = 1). LVDSCLK is a free running clock which can be used to drive LVDS transmitter for DSTN panels. Note: this pin is used as CLK2 for dual panel configuration. For this case configure as LVDSCLK.
~EXCKEN	I	pull-up		60	External Clock Enable. Select external VCLK from CKIN and MCLK from MCKIN.
<i>External Display Memory Interface (for reference only)</i>					
MA [10:0]	O	pull-down	TBD	50	External Memory Address Bus. The video memory row and column addresses are multiplexed on these lines.
MD [63:0]	I/O	MD [63:33] pull-down	TBD	20	
MD [63:0]	I/O	MD[32:0] pull-up	TBD	20	
~WE	O	pull-up	TBD	50	
~RAS	O	pull-up	TBD	50	
~CAS	O	pull-up	TBD	50	External SGRAM Column Address Select
~CS0	O	pull-up	TBD	50	External SGRAM Chip Select 0, select 1st 1MB within the 2MB memory, or select 1st 2MB within the 4MB memory
~DQM [7:0]	O	pull-up	TBD	50	External SGRAM I/O mask [7:0]. DQM [7:0] are byte specific. DQM0 masks MD [7:0], DQM1 masks MD [15:8], DQM2 masks MD [23:16], and DQM7 masks MD [63:58].
DSF	O	pull-up	TBD	50	External SGRAM Block write
BA	O		TBD	50	External SGRAM Bank Select. SDRAM has dual internal banks. Bank address defines to which bank the current command is being applied.
SDCK	I/O	pull-up	TBD	50	External SGRAM clock. SDCK is driven by the memory clock. All SDRAM input signals are sampled on the positive edge of SDCK.
SDCKEN	I/O	pull-up	TBD	50	External SGRAM clock enable. SDCKEN activates (HIGH) and deactivates (LOW) the SDCLK signal. Deactivating the SDCK provides POWER-DOWN and SELF-REFRESH mode. ~ROMEN
~ROMEN	O	pull-up	TBD	20	ROM Enable

Signal Name	Type	Pull-up/ Pull-Down	IOL (mA)	Max. Load (pF)	Description
-------------	------	-----------------------	-------------	-------------------	-------------

Flat Panel Interface

FDATA [47:0]	O	pull-down	TBD	50	Flat Panel Data Bit 47 to Bit 0 for single panel implementation. For Dual Panel Implementation Panel 1: FDA21-16, FDA 13-8, FDA5-0, panel1data Panel 2: FDA23, HSYNC2 FDA22, VSYNC2 FDA15, DE2 FDA47-FDA24, panel 2 data Note: FDA14, FDA7, FDA6 not used for Dual Panel Implementation. LVDSCLK used as SCLK2.
LP/FHSYNC	O	pull-down	TBD	50	DSTN LCD: Line Pulse TFT LCD: LCD Horizontal Sync
FP/FVSYNC	O	pull-down	TBD	50	DSTN LCD: Frame Pulse TFT LCD: LCD vertical sync
M/DE	O	pull-down	TBD	50	M-signal or Display Enable. This signal is used to indicate the active horizontal display time. FPR3E [7] is used to select 1 = M-signal 0 = Display Enable
FPCLK	O	pull-down	TBD	50	Flat Panel Shift Clock. This is the pixel clock for Flat Panel Data.
FPEN	O	pull-down	TBD	20	Flat Panel Enable. This signal needs to become active after all panel voltages, clocks, and data are supplied. This signal also needs to become inactive before any panel voltages or control signals are removed. FPEN is part of the VESA FPD1-1B specification.
FPVDDEN	O	pull-down	TBD	20	Flat Panel VDD Enable. This signal is used to control LCD logic power.
VBIASEN	O	pull-down	TBD	20	Flat Panel Voltage Bias Enable. This signal is used to control LCD Bias power.

CRT Interface

RED	O				Analog Red Current Output
GREEN	O				Analog Green Current Output
BLUE	O				Analog Blue Current Output
IREF	I				Current Reference Input
CRTVSYNC	O	pull-up	TBD	50	CRT Vertical Sync
CRTHSYNC/ CSYNC	O	pull-up	TBD	50	CRT Horizontal Sync or Composite Sync depending on CCR65 [0] 0 = CRT Horizontal Sync 1 = Composite Sync

TV Interface

Y	O				Luminance Output
C	O				Chrominance Output
CVBS	O				Composite Video Output
IREF2	I				Current Reference Input

Video Port Interface

Signal Name	Type	Pull-up/ Pull-Down	IOL (mA)	Max. Load (pF)	Description
P [15:0]	I/O	pull-down	TBD	20	RGB or YUV input/ RGB digital output
PCLK	I/O	pull-up	TBD	20	Pixel Clock
VREF	I/O	pull-up	TBD	20	VSYNC input from PC Card or video decoder
HREF	I/O	pull-up	TBD	20	HSYNC input from PC Card or video decoder
BLANK	O	pull-up	TBD	20	Blank output 0 = BLANK output
General Purpose Registers / I²C					
USR3	I/O	pull-up	TBD	20	General Purpose I/O
USR2	I/O	pull-up	TBD	20	General Purpose I/O
USR1 / SDA	I/O	pull-up	TBD	20	General Purpose I/O. USR1/ DDC2/ I ² C Data for CRT. Can be used to select different test modes.
USR0 / SCL	I/O	pull-up	TBD	20	General Purpose I/O. USR0/ DDC2/ I ² C Clock for CRT. Can be used to select different test modes.
Test Mode Pins					
TEST [1:0]	I	pull-down			Test mode selects
VCC and GROUND Pins					
HVDD					Host Interface VDD on I/O Ring, 3.3V
MIVDD					Integrated Display Memory Interface VDD on I/O Ring, 3.3V (2.5V option)
MEVDD					External Display Memory Interface VDD on I/O ring, 3.3V (2.5V option)
FPVDD					Flat Panel Interface VDD on I/O Ring, 3.3V
VPVDD					VPort Interface VDD on I/O Ring 3.3V
CVDD					Clock (PLL) Analog Power, 2.5V
AVDD					DAC Analog Power, 3.3V
AVDD3					TVDAC Analog Power, 3.3V
RVDD					RAM Filtered Palette Power, 2.5V
CVSS					PLL Analog Ground
AVSS1					DAC Analog Ground
AVSS2					DAC Analog Ground
AVSS3					TVDAC Analog Ground
RVSS					RAM Filtered Palette Ground
VDD					Digital Core Power Supply, 2.5V
VCCA					Digital Memory Power Supply, 3.3V (2.5V option)
VSSA					Digital Internal Memory Ground
VSS					Digital Ground

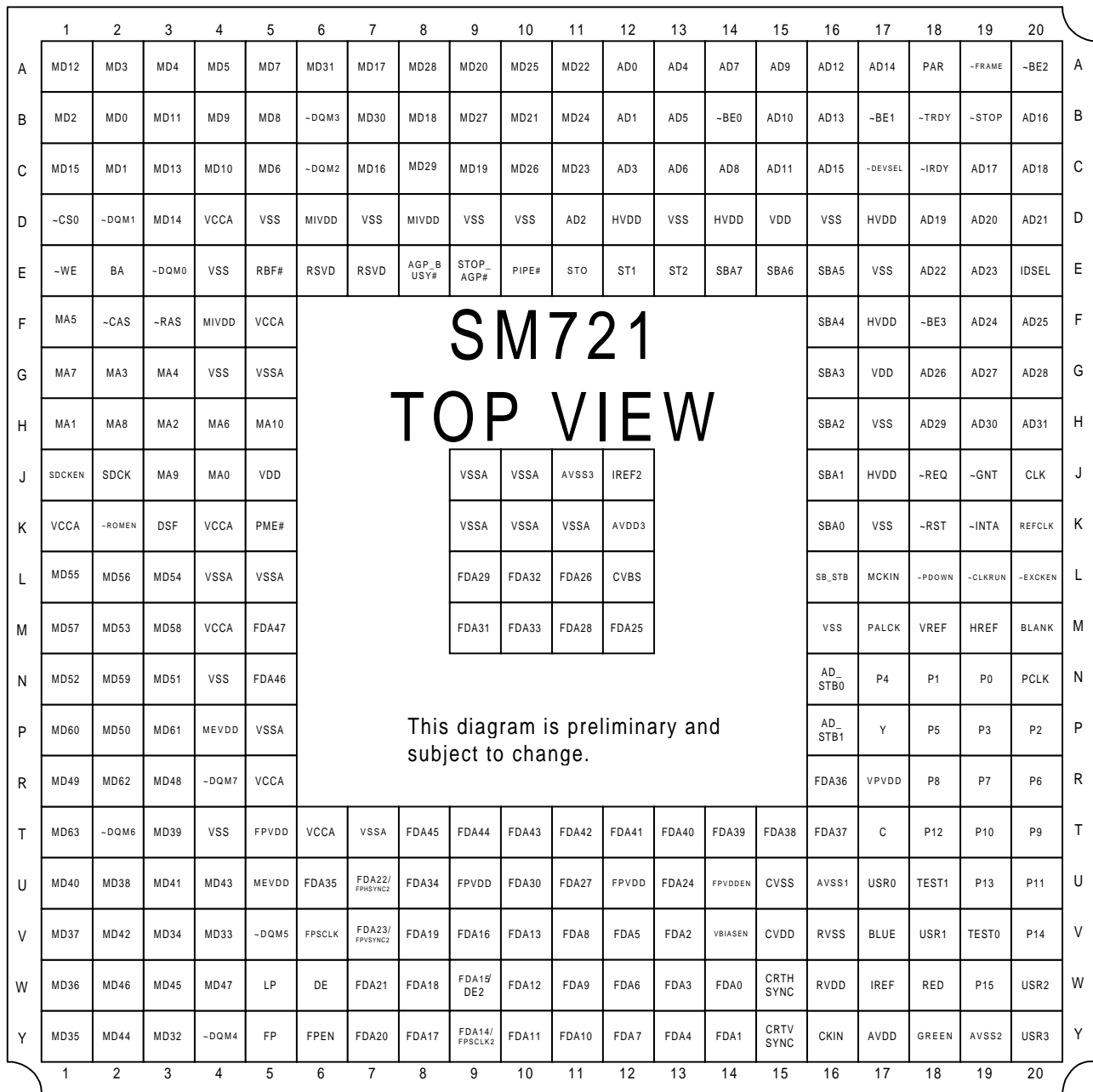

Figure 3: SM721 Pin Diagram for 316 BGA Package

Table 5: Numerical SM721 BGA Pin List

#	SM721 Name	{Function1}	{Function2}	{Function3}	{Function4}	{Function 5}	VDD
A1	MD12						MEVDD
A2	MD3	{ROM}					MEVDD
A3	MD4	ROMD4					MEVDD
A4	MD5	ROMD5					MEVDD
A5	MD7	ROMD7					MEVDD
A6	MD31						MEVDD
A7	MD17						MEVDD
A8	MD28						MEVDD
A9	MD20						MEVDD
A10	MD25						MEVDD
A11	MD22						MEVDD
A12	AD0						HVDD
A13	AD4						HVDD
A14	AD7						HVDD
A15	AD9						HVDD
A16	AD12						HVDD
A17	AD14						HVDD
A18	PAR						HVDD
A19	~FRAME						HVDD
A20	C/~BE2						HVDD
B1	MD2	ROMD2					MEVDD
B2	MD0	ROMD0					MEVDD
B3	MD11						MEVDD
B4	MD9						MEVDD
B5	MD8						MEVDD
B6	~DQM3						MEVDD
B7	MD30						MEVDD
B8	MD18						MEVDD
B9	MD27						MEVDD
B10	MD21						MEVDD
B11	MD24						MEVDD
B12	AD1						HVDD
B13	AD5						HVDD
B14	C/~BE0						HVDD
B15	AD10						HVDD
B16	AD13						HVDD
B17	C/~BE1						HVDD

#	SM721 Name	{Function1}	{Function2}	{Function3}	{Function4}	{Function 5}	VDD
B18	~TDRY						HVDD
B19	~STOP						HVDD
B20	AD16						HVDD
C1	MD15						MEVDD
C2	MD1	ROMD1					MEVDD
C3	MD13						MEVDD
C4	MD10						MEVDD
C5	MD6	ROMD6					MEVDD
C6	~DQM2						MEVDD
C7	MD16						MEVDD
C8	MD29						MEVDD
C9	MD19						MEVDD
C10	MD26						MEVDD
C11	MD23						MEVDD
C12	AD3						HVDD
C13	AD6						HVDD
C14	AD8						HVDD
C15	AD11						HVDD
C16	AD15						HVDD
C17	~DEVSEL						HVDD
C18	~IDRY						HVDD
C19	AD17						HVDD
C20	AD18						HVDD
D1	~CS0						MEVDD
D2	~DQM1						MEVDD
D3	MD14						MEVDD
D4	VCCA						
D5	VSS						
D6	MIVDD						
D7	VSS						
D8	MIVDD						
D9	VSS						
D10	VSS						
D11	AD2						HVDD
D12	HVDD						
D13	VSS						
D14	HVDD						
D15	VDD						
D16	VSS						

#	SM721 Name	{Function1}	{Function2}	{Function3}	{Function4}	{Function 5}	VDD
D17	HVDD						
D18	AD19						HVDD
D19	AD20						HVDD
D20	AD21						HVDD
E1	~WE						MEVDD
E2	BA						MEVDD
E3	~DQM0						MEVDD
E4	VSS						
E5	~RBF						
E6	Reserved						
E7	Reserved						
E8	~AGP_BUSY						HVDD
E9	~STOP_AGP						HVDD
E10	~PIPE						HVDD
E11	ST0						HVDD
E12	ST1						HVDD
E13	ST2						HVDD
E14	SBA7						HVDD
E15	SBA6						HVDD
E16	SBA5						HVDD
E17	VSS						
E18	AD22						HVDD
E19	AD23						HVDD
E20	IDSEL						HVDD
F1	MA5						MEVDD
F2	~CAS						MEVDD
F3	~RAS						MEVDD
F4	MIVDD						
F5	VCCA						
F16	SBA4						HVDD
F17	HVDD						
F18	C/~BE3						HVDD
F19	AD24						HVDD
F20	AD25						HVDD
G1	MA7						MEVDD
G2	MA3						MEVDD
G3	MA4						MEVDD
G4	VSS						
G5	VSSA						

#	SM721 Name	{Function1}	{Function2}	{Function3}	{Function4}	{Function 5}	VDD
G16	SBA3						HVDD
G17	VDD						
G18	AD26						HVDD
G19	AD27						HVDD
G20	AD28						HVDD
H1	MA1						MEVDD
H2	MA8						MEVDD
H3	MA2						MEVDD
H4	MA6						MEVDD
H5	MA10						MEVDD
H16	SBA2						HVDD
H17	VSS						
H18	AD29						HVDD
H19	AD30						HVDD
H20	AD31						HVDD
J1	SDCKEN						MEVDD
J2	SDCK						MEVDD
J3	MA9						MEVDD
J4	MA0						MEVDD
J5	VDD						
J9	VSSA						
J10	VSSA						
J11	AVSS3						
J12	IREF2						
J16	SBA1						HVDD
J17	HVDD						
J18	~REQ						HVDD
J19	~GNT						HVDD
J20	CLK						HVDD
K1	VCCA						
K2	~ROMEN						MEVDD
K3	DSF						MEVDD
K4	VCCA						
K5	~PME						HVDD
K9	VSSA						
K10	VSSA						
K11	VSSA						
K12	AVDD3						
K16	SBA0						HVDD

#	SM721 Name	{Function1}	{Function2}	{Function3}	{Function4}	{Function 5}	VDD
K17	VSS						
K18	\bar{RST}						HVDD
K19	\bar{INTA}						HVDD
K20	REFCLK						HVDD
L1	MD55						MEVDD
L2	MD56						MEVDD
L3	MD54						MEVDD
L4	VSSA						
L5	VSSA						
L9	FDATA29				GA5		FPVDD*
L10	FDATA32				RA4		FPVDD*
L11	FDATA26				BB4		FPVDD*
L12	CVBS	{EXT CLK}		{LVDS}			
L16	SB_STB						HVDD
L17	MCKIN/LVDSCK	MCKIN		LVDSCK		SCLK2	HVDD
L18	\bar{PDOWN}						HVDD
L19	\bar{CLKRUN} /ACTIVITY						HVDD
L20	\bar{EXCKEN}						HVDD
M1	MD57					Panel 1 TFTx18	MEVDD
M2	MD53					Panel 2 TFTx24	MEVDD
M3	MD58					[multi-panel]	MEVDD
M4	VCCA						
M5	FDATA47					FP2_R7	FPVDD
M9	FDATA31				GB5	FP2_B7	FPVDD*
M10	FDATA33				RA5	FP2_G1	FPVDD*
M11	FDATA28				GA4	FP2_B4	FPVDD*
M12	FDATA25				BA5	FP2_B1	FPVDD*
M16	VSS						
M17	(PALCK)						
		{ZV IN}		{TESTMODE1}			
M18	VREF	VS		TD19			VPVDD
M19	HREF	HREF	{External TV encoder}	TD18			VPVDD
M20	BLANK		TVCLK	TD17			VPVDD
N1	MD52						MEVDD
N2	MD59						MEVDD
N3	MD51						MEVDD
N4	VSS						

#	SM721 Name	{Function1}	{Function2}	{Function3}	{Function4}	{Function 5}	VDD
N5	FDATA46					FP2_R6	FPVDD
N16	AD_STB0						HVDD
N17	P4	UV4		TD4			VPVDD
N18	P1	UV1		TD1			VPVDD
N19	P0	UV0		TD0			VPVDD
N20	PCLK	PCLK		TD16			VPVDD
P1	MD60						MEVDD
P2	MD50						MEVDD
P3	MD61						MEVDD
P4	MEVDD						
P5	VSSA						
P16	AD_STB1						HVDD
P17	Y						
		{ZV IN}					
P18	P5	UV5		TD5			VPVDD
P19	P3	UV3		TD3			VPVDD
P20	P2	UV2		TD2			VPVDD
R1	MD49						MEVDD
R2	MD62						MEVDD
R3	MD48						MEVDD
R4	~DQM7						MEVDD
R5	VCCA						
R16	FDATA36					FP2_G4	FPVDD
R17	VPVDD						
R18	P8	Y0		TD8			VPVDD
R19	P7	UV7		TD7			VPVDD
R20	P6	UV6		TD6			VPVDD
T1	MD63						MEVDD
T2	~DQM6	{ROM}					MEVDD
T3	MD39	ROMA7					MEVDD
T4	VSS						
T5	FPVDD						
T6	VCCA						
T7	VSSA						
T8	FDATA45					FP2_R5	FPVDD
T9	FDATA44					FP2_R4	FPVDD
T10	FDATA43					FP2_R3	FPVDD
T11	FDATA42					FP2_R2	FPVDD
T12	FDATA41					FP2_R1	FPVDD

#	SM721 Name	{Function1}	{Function2}	{Function3}	{Function4}	{Function 5}	VDD
T13	FDATA40					FP2_R0	FPVDD
T14	FDATA39					FP2_G7	FPVDD
T15	FDATA38					FP2_G6	FPVDD
T16	FDATA37					FP2_G5	FPVDD
T17	C	{ZV IN}					
T18	P12	Y4		TD12			VPVDD
T19	P10	Y2		TD10			VPVDD
T20	P9	Y1		TD9			VPVDD
		{ROM}					
U1	MD40	ROMA8					MEVDD
U2	MD38	ROMA6					MEVDD
U3	MD41	ROMA9					MEVDD
U4	MD43	ROMA11					
U5	MEVDD						
U6	FDATA35	{DSTN}				FP2_G3	FPVDD*
U7	FDATA22	UD10	Ro2			FPHSYNC2	FPVDD
U8	FDATA34					FP2_G2	FPVDD*
U9	FPVDD						
U10	FDATA30					FP2_B6	FPVDD*
U11	FDATA27					FP2_B3	FPVDD*
U12	FPVDD						
U13	FDATA24					FP2_B0	
U14	FPVDDEN					FPVDDEN1	FPVDD
U15	CVSS						
U16	AVSS1	{I2C/DDC}	{USR CFG}				
U17	USR0/SCL	SCL (Prim)	USR0				VPVDD
U18	TEST1	{ZV IN}		TEST1			VPVDD
U19	P13	Y5		TD13			VPVDD
U20	P11	Y3		TD11			VPVDD
		{ROM}					
V1	MD37	ROMA5					MEVDD
V2	MD42	ROMA10					MEVDD
V3	MD34	ROMA2					MEVDD
V4	MD33	ROMA1					MEVDD
V5	~DQM5	{DSTN}					MEVDD
V6	FPSCCLK	XCK				FPSCCK1	FPVDD
V7	FDATA23	UD11	Ro3			FPVSYNC2	FPVDD
V8	FDATA19	UD7	Re3			FP1_R3	FPVDD
V9	FDATA16	UD4	Re0			FP1_R0	FPVDD

#	SM721 Name	{Function1}	{Function2}	{Function3}	{Function4}	{Function 5}	VDD
V10	FDATA13	UD1	Go1			FP1_G5	FPVDD
V11	FDATA8	LD8	Ge0			FP1_G0	FPVDD
V12	FDATA5	LD5	Bo1			FP1_B5	FPVDD
V13	FDATA2	LD2	Be2			FP1_B2	FPVDD
V14	VBIASEN					VBIASEN1	FPVDD
V15	CVDD						
V16	RVSS						
V17	BLUE	{I2C/DDC}	{USR CFG}				
V18	USR1/SDA	SDA (Prim)	USR1				VPVDD
V19	TEST0	{ZV IN}		TEST0			VPVDD
V20	P14	Y6		TD14			VPVDD
		{ROM}					
W1	MD36	ROMA4					MEVDD
W2	MD46	ROMA14					MEVDD
W3	MD45	ROMA13					MEVDD
W4	MD47	ROMA15					MEVDD
		{DSTN}					
W5	LP/FHSYNC	LP				HSYNC1	FPVDD
W6	M/ DE	M/DE				DE1	FPVDD
W7	FDATA21	UD9	Ro1			FP1_R5	FPVDD
W8	FDATA18	UD6	Re2			FP1_R2	FPVDD
W9	FDATA15	UD3	Go3			DE2	FPVDD
W10	FDATA12	UD0	Go0			FP1_G4	FPVDD
W11	FDATA9	LD9	Ge1			FP1_G1	FPVDD
W12	FDATA6	LD6	Bo2				FPVDD
W13	FDATA3	LD3	Be3			FP1_B3	FPVDD
W14	FDATA0	LD0	Be0			FP1_B0	FPVDD
W15	CRTHSYNC						VPVDD
W16	RVDD						
W17	IREF						
W18	RED	{ZV IN}					
W19	P15	Y7		TD15			VPVDD
		{I2C/DDC}	{USR CFG}				
W20	USR2	SCL	USR2/ NTSCPAL			SCL2	VPVDD
		{ROM}					
Y1	MD35	ROMA3					MEVDD
Y2	MD44	ROMA12					MEVDD
Y3	MD32	ROMA0					MEVDD
Y4	~DQM4	{DSTN}			{TFT}		MEVDD

#	SM721 Name	{Function1}	{Function2}	{Function3}	{Function4}	{Function 5}	VDD
Y5	FP/ FVSYNC	FP			FVSYNC	VSYNC1	FPVDD
Y6	FPEN	FPEN	{TFT 18x2}		FPEN	FPEN	FPVDD
Y7	FDATD20	UD8	Ro0		R4	FP1_R4	FPVDD
Y8	FDATA17	UD5	Re1		R1	FP1_R1	FPVDD
Y9	FDATA14	UD2	Go2		G6		FPVDD
Y10	FDATA11	LD11	Ge3		G3	FP1_G3	FPVDD
Y11	FDATA10	LD10	Ge2		G2	FP1_G2	FPVDD
Y12	FDATA7	LD7	Bo3		B7		FPVDD
Y13	FDATA4	LD4	Bo0		B4	FP1_B4	FPVDD
Y14	FDATA1	LD1	Be1		B1	FP1_B1	FPVDD
Y15	CRTVSYNC						FPVDD
Y16	CKIN						
Y17	AVDD						
Y18	GREEN						
Y19	AVSS2	{I2C/DDC2}	{USR CFG}				
Y20	USR3	SDA	USR3/ TVONOFF			SDA2	VPVDD

Notes: The reserved signals are for future products.

Table 6: Lynx3DM VCC and GROUND Connections

VCC Pin	Location	Supply Voltage	Description
HVDD	D12	3.3V	Host interface VDD
HVDD	D14	3.3V	Host interface VDD
HVDD	D17	3.3V	Host interface VDD
HVDD	F17	3.3V	Host interface VDD
HVDD	J17	3.3V	Host interface VDD
MIVDD	D6	3.3V/2.5V ¹	Integrated memory VDD. Allow option for 3.3V or 2.5V connection.
MIVDD	D8	3.3V/2.5V ¹	Integrated memory VDD. Allow option for 3.3V or 2.5V connection.
MIVDD	F4	3.3V/2.5V ¹	Integrated memory VDD. Allow option for 3.3V or 2.5V connection.
MEVDD	P4	3.3V/2.5V ¹	External memory VDD. Allow option for 3.3V or 2.5V connection.
MEVDD	U5	3.3V/2.5V ¹	External memory VDD. Allow option for 3.3V or 2.5V connection.
FPVDD	T5	3.3V	Flat panel interface VDD
FPVDD	U9	3.3V	Flat panel interface VDD
FPVDD	U12	3.3V	Flat panel interface VDD
VPVDD	R17	3.3V	ZVPort Interface VDD
CVDD	V15	2.5V	Clock PLL analog power
AVDD	Y17	3.3V	CRT DAC analog power
AVDD3	K12	3.3V	TVDAC analog power

VCC Pin	Location	Supply Voltage	Description
RVDD	W16	2.5V	RAM palette power
VDD	D15	2.5V ²	Core power
VDD	G17	2.5V ²	Core power
VDD	J5	2.5V ²	Core power
VCCA	F5	3.3V/2.5V ¹	Integrated memory power. Allow for 3.3V or 2.5V connection
VCCA	K4	3.3V/2.5V ¹	Integrated memory power. Allow for 3.3V or 2.5V connection
VCCA	M4	3.3V/2.5V ¹	Integrated memory power. Allow for 3.3V or 2.5V connection
VCCA	R5	3.3V/2.5V ¹	Integrated memory power. Allow for 3.3V or 2.5V connection
VCCA	K1	3.3V/2.5V ¹	Integrated memory power. Allow for 3.3V or 2.5V connection
VCCA	D4	3.3V/2.5V ¹	Integrated memory power. Allow for 3.3V or 2.5V connection
VCCA	T6	3.3V/2.5V ¹	Integrated memory power. Allow for 3.3V or 2.5V connection
Ground			
CVSS	U15		Clock PLL analog ground
AVSS1	U16		DAC analog ground
AVSS2	Y19		DAC analog ground
AVSS3	J11		TVDAC analog ground
RVSS	V16		RAM palette ground
VSS	D5,D7,D9,D10,D13,D16,E4,E17,G4,H17,M16		Digital ground
VSSA	G5,J9,J10,K9,K10, K11L4,L5,P5,T7		Digital memory ground

¹2.5V future option.

² Recommend selectable 2.5V or 3.3V core power option.

Lynx3DM NAND Tree Scan Testing

The Lynx3DM NAND Tree scan test circuit is designed for verifying the device being properly soldered to the board (NAND support for SM721 only). It detects opened/shorted traces of a signal pin with a simple test pattern which, for this particular case, only ~243 vectors in length. Since the NAND Tree scan test circuit uses Combination logic; therefore, no clock pulses are required during the testing.

General Information

The Lynx3DM NAND Tree scan test circuit is a long chain of 2-input NAND gates. The first pin of the NAND chain is an input (signal pin "~ROMEN"), the last pin of the chain is an output (signal pin "BLANK"). In order to setup Lynx3DM for NAND Tree testing, USR[3:0] pins are programmed to 0010h and Test[1:0] pins to 10h. ALL VDD's, VSS's, and Analog pins RED, GREEN, BLUE, IREF, C, Y, CVBS, IREF2 are not included in the scan chain.

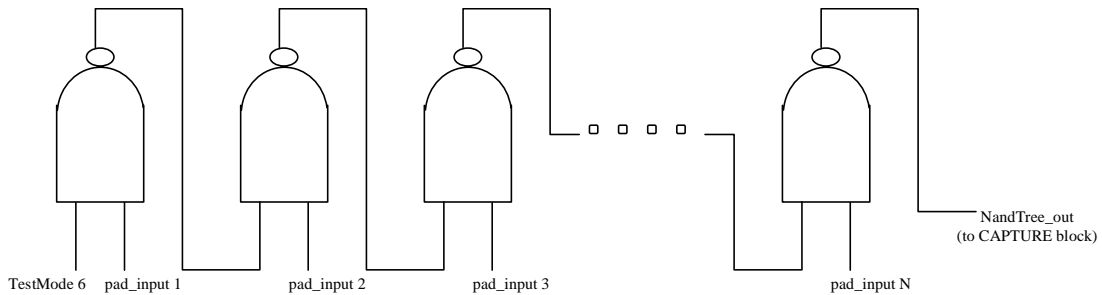

Figure 4: NAND Tree Connection

NAND Tree Simulation

In order to setup Lynx3DM to NAND Tree scan test mode, USR[3:0] and Test[1:0] pins are programmed to 0010h and 10h respectively. In NAND Tree mode, internal signal TestMode6 is a "1" (active "High" signal). In the beginning of the simulation, all inputs are forced to "1". Then, follow the NAND Tree PAD sequence and change each input to "0" every 400ns, starting with input_0 (signal "~ROMEN"). The Output pin (signal "BLANK") should be a clock waveform that toggles every 400ns (a 2.5MHz square waveform) (See Figure 5). Any mismatch in the waveform would mean the device was not properly soldered to the board.

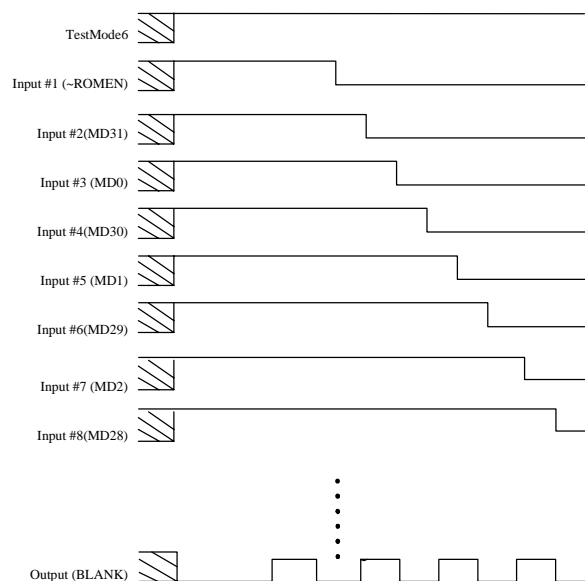

Figure 5: NAND Tree Simulation Timing Diagram

Table 7: NAND Tree Scan Test Order

NAND TREE SCAN PIN ORDER#	Pin Name	In/Out
1	~ROMEN	In
2	MD31	In
3	MD0	In
4	MD30	In
5	MD1	In
6	MD29	In
7	MD2	In
8	MD28	In
9	MD3	In
10	MD27	In
11	MD26	In
12	MD4	In
13	MD25	In
14	MD5	In
15	MD24	In
16	MD6	In
17	MD7	In
18	MD16	In
19	MD15	In
20	MD17	In
21	MD14	In
22	MD18	In
23	MD13	In
24	MD19	In
25	MD12	In
26	MD20	In
27	MD11	In
28	MD21	In
29	MD10	In
30	MD9	In
31	MD22	In
32	MD8	In
33	MD23	In
34	~DQM3	In
35	~DQM0	In
36	~DQM1	In
37	SDCK	In
38	~DQM2	In
39	SDCKEN	In
40	MA1	In
41	DSF	In

NAND TREE SCAN PIN ORDER#	Pin Name	In/Out
42	MA2	In
43	MA9	In
44	MA3	In
45	MA7	In
46	MA4	In
47	MA0	In
48	MA5	In
49	MA8	In
50	BA	In
51	MA6	In
52	~CS0	In
53	MA10	In
54	~RAS	In
55	~DQM5	In
56	~CAS	In
57	~DQM7	In
58	~WE	In
59	~DQM6	In
60	~DQM4	In
61	MD40	In
62	MD55	In
63	MD41	In
64	MD54	In
65	MD42	In
66	MD53	In
67	MD43	In
68	MD52	In
69	MD44	In
70	MD51	In
71	MD45	In
72	MD50	In
73	MD46	In
74	MD49	In
75	MD47	In
76	MD48	In
77	MD56	In
78	MD39	In
79	MD57	In
80	MD38	In
81	MD58	In
82	MD37	In
83	MD59	In

NAND TREE SCAN PIN ORDER#	Pin Name	In/Out
84	MD36	In
85	MD35	In
86	MD60	In
87	MD34	In
88	MD61	In
89	MD33	In
90	MD62	In
91	MD32	In
92	MD63	In
93	FDATA47	In
94	FDATA46	In
95	FPHSYNC/LP	In
96	FPVSYNC/FP	In
97	FDATA35	In
98	FPCLK	In
99	DE	In
100	FPEN	In
101	FDATA45	In
102	FDATA22	In
103	FDATA23	In
104	FDATA20	In
105	FDATA21	In
106	FDATA19	In
107	FDATA29	In
108	FDATA16	In
109	FDATA34	In
110	FDATA44	In
111	FDATA30	In
112	FDATA43	In
113	FDATA31	In
114	FDATA18	In
115	FDATA17	In
116	FDATA13	In
117	FDATA33	In
118	FDATA15	In
119	FDATA14	In
120	FDATA12	In
121	FDATA11	In
122	FDATA41	In
123	FDATA32	In
124	FDATA42	In
125	FDATA27	In

NAND TREE SCAN PIN ORDER#	Pin Name	In/Out
126	FDATA5	In
127	FDATA8	In
128	FDATA6	In
129	FDATA9	In
130	FDATA10	In
131	FDATA26	In
132	FDATA7	In
133	FDATA40	In
134	FDATA39	In
135	FDATA38	In
136	FDATA28	In
137	FDATA24	In
138	FPVDDEN	In
139	FDATA2	In
140	FDATA3	In
141	VBIASEN	In
142	FDATA25	In
143	FDATA0	In
144	FDATA4	In
145	FDATA1	In
146	FDATA36	In
147	FDATA37	In
148	CKIN	In
149	CRTVSYNC	In
150	CRTHSYNC	In
151	~EXCKEN	In
152	REFCLK	In
153	~PDOWN	In
154	MCKIN	In
155	PALCLK	In
156	HREF	In
157	VREF	In
158	P15	In
159	P14	In
160	P13	In
161	P12	In
162	P11	In
163	P10	In
164	P9	In
165	PCLK	In
166	P8	In
167	P7	In

NAND TREE SCAN PIN ORDER#	Pin Name	In/Out
168	P5	In
169	P6	In
170	P4	In
171	P3	In
172	P2	In
173	P1	In
174	P0	In
175	~CLKRUN	In
176	~REQ	In
177	AD29	In
178	SBA1	In
179	AD30	In
180	SBA2	In
181	~GNT	In
182	~RST	In
183	~INTA	In
184	SBA0	In
185	AD31	In
186	SBSTB	In
187	AD28	In
188	AD_STB0	In
189	AD27	In
190	AD_STB1	In
191	AD25	In
192	AD26	In
193	IDSEL	In
194	SBA3	In
195	AD21	In
196	SBA4	In
197	AD18	In
198	CLK	In
199	AD24	In
200	AD15	In
201	AD23	In
202	C/~BE3	In
203	AD22	In
204	SBA5	In
205	AD20	In
206	AD19	In
207	~STOP	In
208	AD17	In
209	C/~BE2	In

NAND TREE SCAN PIN ORDER#	Pin Name	In/Out
210	AD16	In
211	~IRDY	In
212	~TRDY	In
213	~FRAME	In
214	~DEVSEL	In
215	PAR	In
216	C/~BE1	In
217	AD14	In
218	AD12	In
219	AD13	In
220	AD9	In
221	AD10	In
222	AD11	In
223	SBA6	In
224	AD7	In
225	C/~BE0	In
226	AD8	In
227	SBA7	In
228	AD4	In
229	AD5	In
230	AD6	In
231	ST2	In
232	AD0	In
233	AD1	In
234	AD3	In
235	ST1	In
236	AD2	In
237	ST0	In
238	PIPE#	In
239	STOP_AGP#	In
240	AGP_BUSY#	In
241	RBF#	In
242	PME#	In
243	BLANK	Out

Chapter 3: Initialization

Lynx3DM generates an internal power-on reset during system power-on. After receiving the system \sim RESET signal, Lynx3DM will release its internal power-on reset circuit and enter the RESET period until the host de-asserts the \sim RESET signal. During the RESET period, Lynx3DM resets its internal state machines and registers to the power-on default states. During power-on, Lynx3DM is configured based on configuration lines MD [22:0].

Table 8 provides a detailed description of each configuration line. All MD (memory data) lines have internal pull-up resistors on I/O pads which are latched into the corresponding register as logic "1" on the rising edge (trailing edge) of the \sim RESET. To set a specific bit as logic "0" during power-on reset, an external pull-down resistor must be added on the corresponding MD line.

In addition to power-on configuration, Lynx3DM performs an initialization sequence for the integrated memory.

After memory initialization has been completed, Lynx3DM's video BIOS is ready to service system BIOS requests. System BIOS passes a pointer to the Lynx3DM video BIOS to start the video BIOS initialization sequence.

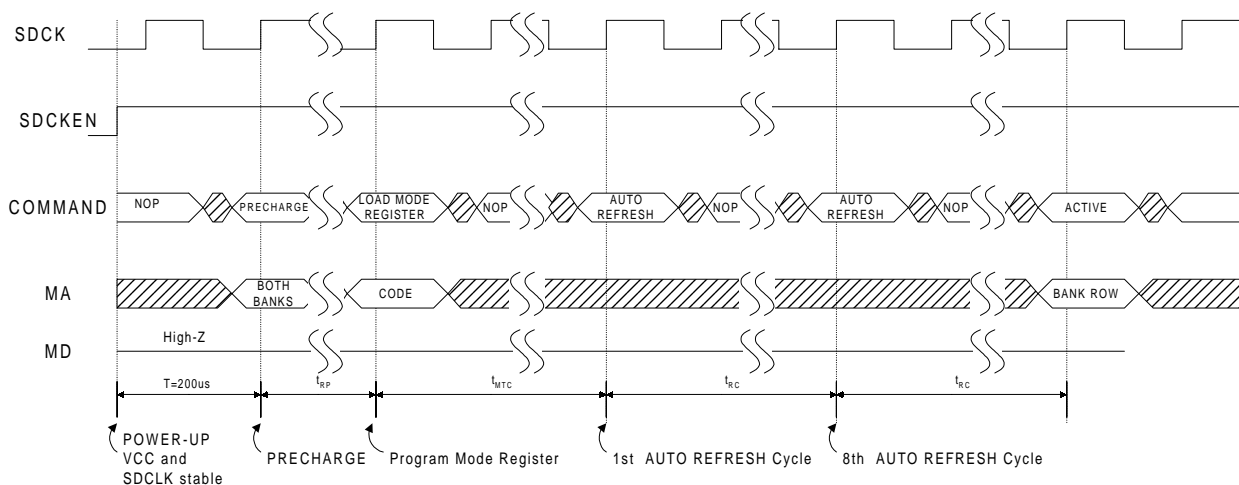

Figure 6: SGRAM Power-Up and Initialization Sequence

Figure 7 illustrates the Lynx3DM Video BIOS initialization flow. The initialization sequence consists of the following stages:

- Load configuration table
- Get panel 2D
- Initialize INT10 function
- Initialize hardware
- Query system BIOS via Int 15 calls
- Set initial mode
- Enable the display

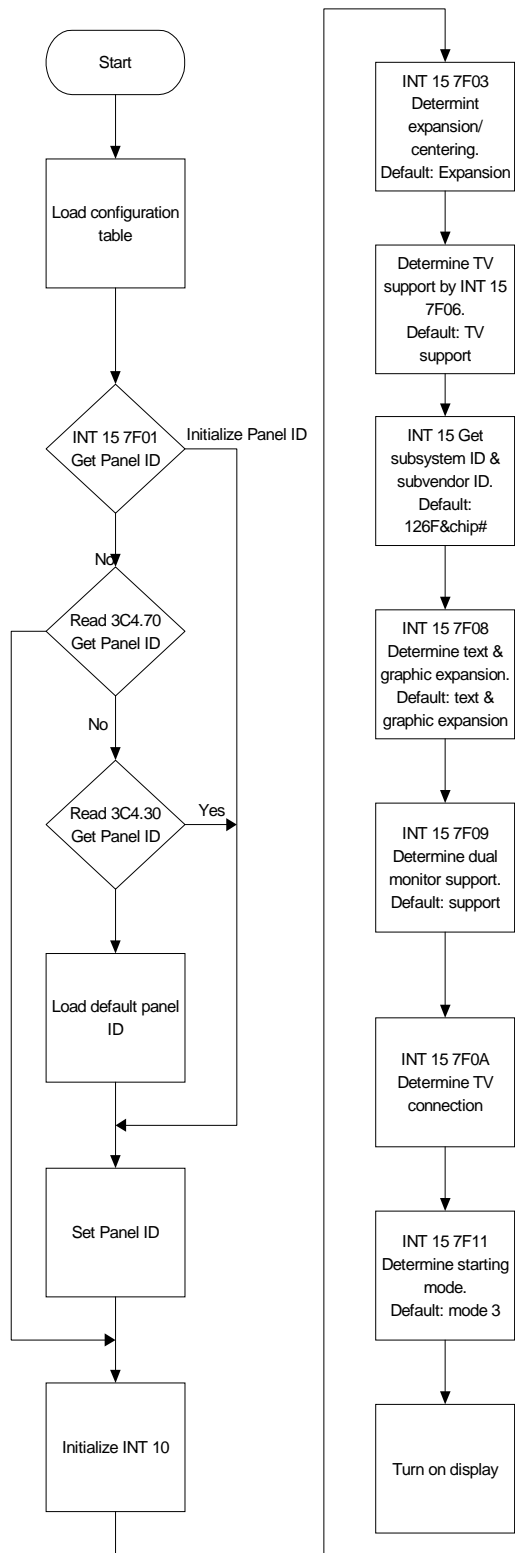

Figure 7: Lynx3DM Video BIOS Initialization Flow

Lynx3DM Power-On Configurations

- Memory data bit [63:33] have pull-down resistors on I/O pads
- Memory data bit [32:0] have internal pull-up resistors on I/O pads
- 0 = external pull-down resistor
- 1 = no external pull-down resistor

Table 8: Power-On Configurations

Signal Name	Read/Write	Register Bits	Address	Lynx3DM Description
MD [32]	CONFIG ONLY			Enable AGP sideband signals 0 = Disable 1 = Enable
MD [31:30]	R/W	MCR76 [7:6]	3C5h.76	Reserved
MD [29:28]	R/W	MCR76 [5:4]	3C5h.76	Reserved
MD [27]	R/W	MCR76 [3]	3C5h.76	External Memory Block Write Cycle Time 0 = 1 MCLK 1 = 2 MCLK
MD [26]	R/W	MCR76 [2]	3C5h.76	Enable External Memory 0 = Disable External Memory 1 = Enable External Memory
MD [25]	R/W	MCR76 [1]	3C5h.76	External SGRAM Memory Active to Precharge Delay (tras) 0 = 4 MCLK 1 = 3 MCLK
MC [24]	R/W	MCR76 [0]	3C5h.76	External SGRAM Memory Refresh to Command Delay (trc) 0 = 8 MCLK 1 = 7 MCLK
MD [23]	CONFIG ONLY	CPR00 [25]		External pull-down is required
MD [22]	CONFIG ONLY			Bios Size Configuration 0 = 32KB 1 = 64KB
MD [21]	CONFIG ONLY			EBROM Access 0 = Enable C0000 access when expansion ROM is disabled (MD [20] = pullup) 1 = Disable C0000 access
MD [20]	CONFIG ONLY			Expansion ROM 0 = Expansion ROM 1 = no Expansion ROM (default)
MD [19:16]	R/W	GPR70 [3:0]	3C5h.70	Panel ID Configuration Refer to BIOS Spec for panel ID definition
MD15	R/W	FPR30 [7]	3C5h.30	DSTN Interface Type 0 = 16-bit interface 1 = 24-bit interface
MD [14:12]	R/W	FPR30 [6:4]	3C5h.30	Color TFT Interface Type 000 = 9-bit, 3-bit per R, G, B 001 = 12-bit, 4-bit per R, G, B 010 = 18-bit, 6-bit per R, G, B 011 = 24-bit, 8-bit per R, G, B 100 = 24-bit, (12+12-bit, 2 pixels/clock) 101 = Analog TFT w/ analog R, G, B interface 110 = 36-bit, (18+18-bit, 2 pixels/clock) 111 = 48-bit, (24+24-bit, 2 pixels/clock)

Signal Name	Read/Write	Register Bits	Address	Lynx3DM Description
MD [11:10]	R/W	FPR30 [3:2]	3C5h.30	LCD Display Size 00 = 640 x 480 01 = 800 x 600 10 = 1024 x 768 11 = 1280 x 1024
MD9	R/W	FPR30 [1]	3C5h.30	TFT FPCLK Select 0 = Normal 1 = Inverted
MD8	R/W	FPR30 [0]	3C5h.30	Color LCD Type 0 = color TFT 1 = color STN
MD [7:6]	R/W	MCR62 [7:6]	3C5h.62	Internal Memory DRAM size 10 = 8 MB of internal memory 11 = 4 MB of internal memory 0x = Reserved
MD [5:4]	R/W	MCR62 [5:4]	3C5h.62	Internal SGRAM Memory Column Address Select 10 = 9-bit column address 11 = 8-bit column address 0x = 10-bit column address
MD3	R/W	MCR62 [3]	3C5h.62	Internal Memory Block Write Cycle Time 0 = 1 MCLK 1 = 2 MCLK
MD2	R/W	MCR62 [2]	3C5h.62	Memory Data Bus Size 0 = 128-bit Memory Data Bus 1 = 64-bit Memory Data Bus
MD1	R/W	MCR62 [1]	3C5h.62	Internal SGRAM Memory Active to Precharge Delay (tras) 0 = 4 MCLK 1 = 3 MCLK
MD0	R/W	MCR62 [0]	3C5h.62	Internal SGRAM Memory Refresh to Command Delay (trc) 0 = 8 MCLK 1 = 7 MCLK

Chapter 4: PCI/AGP Bus Interface

Lynx3DM provides a glue-less interface to the PCI and AGP system bus. The device is fully compliant with PCI Version 2.1. The PCI interface 5V tolerant. Lynx3DM's PCI Host Interface Unit supports both slave and master mode. To maximize performance, the Host Interface Unit also supports burst write, and burst read with Read Look Ahead. When connected to the AGP interface, Lynx3DM supports AGP 2X with sideband.

The Lynx3DM's PCI/AGP Host Interface Unit manages data transfer between the external PCI/AGP bus and internal Host Interface (HIF) bus. All functional blocks, with the exception of the Drawing Engine, are tied to the HIF bus through a proprietary protocol. Separate decode logic and a dedicated FIFO are used for the Drawing Engine.

In addition to PCI Configuration Space Registers, the PCI/AGP Host Interface Unit contains Power Down Control Registers (PDR20-PDR23) and System Control Registers (SCR10-SCR1A). These Registers may be accessed by the CPU even while internal PLLs are turned off.

PCI Configuration Registers

The PCI configuration registers are designated CSR00 - CSR3D. A brief description of key elements of the register set follows:

- Vendor ID register (CSR00) - hardwired to 126Fh to identify Silicon Motion, Inc as the chip vendor.
- Device ID register (CSR02) - hardwired to 0720h to identify the Lynx3DM device.
- Status register (CSR06) - hardwired to 01b, which indicates medium speed for ~DEVSEL.
- Class Code register (CSR08) - hardwired to 030000h to specify Lynx3DM as a VGA compatible device. Bit [7:0] used to identify the revision of the Lynx3DM.
- Memory Base Address register (CSR10) - specifies the PCI configuration space for address relocation. After power-on, the register defaults to 00h, which indicates the base register can be located anywhere in a 32-bit address space and that the base register is located in memory space.
- Subsystem Vendor ID and Subsystem ID (addressable at CSR2C and CSR2E respectively) - 32-bit read only registers. These registers are used to differentiate between multiple graphics adapters within the same system.

Chapter 5: Display Memory Interface

Memory Configuration

The Lynx3DM supports a total of 16MB of integrated memory. The memory interface is 128 bits wide and is clocked at 100 MHz, for a total bandwidth of 1.6GB/s peak. To accomplish this when configured with 16MB, Lynx3DM uses two 1Mx64 SGRAM memory devices running in parallel.

Page Break Look Ahead

For standard architectures, the memory controller will break cycle when bus agent changes. Lynx3DM can allow a "No Wait Cycle" during agent changes if the preceding and current agents are in the same page. Both the embedded memory bus and external memory bus support this capability.

Memory Timing Control

Memory timing control is configurable via MD [7:0] and MD [31:24] during power-on reset. When equipped with 16MB, the configuration bits MD [7:0] control 1Mx64 SGRAM timing, while MD [31:24] control the other 1Mx64 SGRAM timing. They should always be set the same. See Reference Table 10 in the Initialization section for a complete description of these memory configuration bits.

Note: MD[63-33] has internal pull-down resistors and MD[32-0] has pull-up resistors on I/O pads. The default configuration is therefore a logical "1" during power-on reset. To set an MD line to 0, an external pull-down resistor needs to be added. After power-on initialization, software can be used to overwrite the initial setting by writing to MCR62 - bits [7:0] correspond to MD [7:0], and MCR76 - bits [7:0] correspond to MD [31:24].

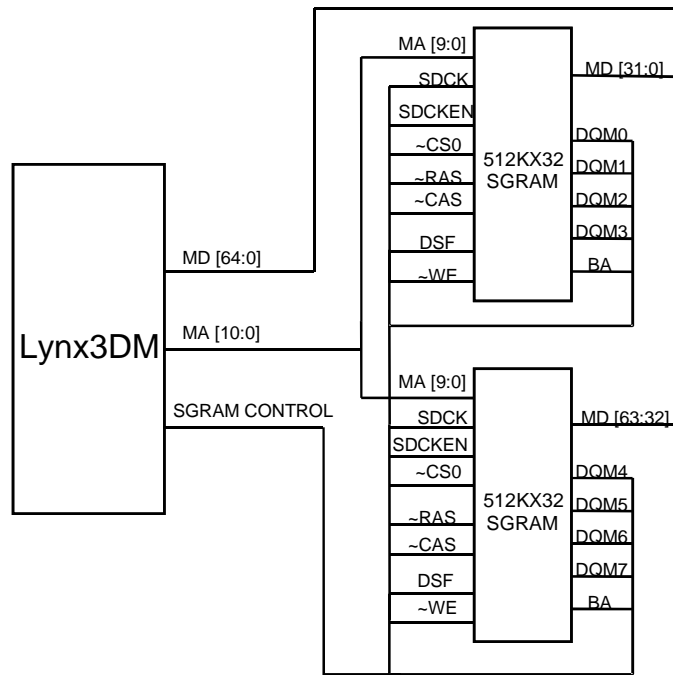

Figure 8: External 4MB SGRAM Configuration (2x512Kx32)

Chapter 6: Drawing Engine

Lynx3DM's 128-bit Drawing Engine is designed to accelerate Microsoft's DirectDraw and Direct3D applications. The engine contains a 3-operand ALU with 256 raster operations, source and destination FIFOs, as well as a host data FIFO. The drawing engine pipeline allows single cycle operations and runs at the memory clock speed.

Lynx3DM's Drawing Engine includes several key functions to achieve the high GUI performance. The device supports color expansion with packed mono font, color pattern fill, host BLT, stretch BLT, short stroke, line draw, and others. Dedicated pathways are designed to transfer data between host interface (HIF) bus and Drawing Engine, and memory interface (MIF) bus and Drawing Engine. In addition, the drawing engine supports rotation BIBLT for any block size, and automatic self activate rotation BLIT. This feature allows conversion between landscape and portrait display without the need for special software drivers.

The Drawing Engine offers several 3D assist features. The Drawing Engine supports low-resolution modes and hardware arithmetic stretching to allow 3D to be rendered to a smaller back buffer and scaled up to the front buffer. Lynx3DM also supports fast DMA BLT, source clear during BLT, transparent BLT, programmable blter stride, page flip, and current scan line refresh.

Lynx3DM's Drawing Engine is also used to bus master captured data to the hard disk drive or to system memory during video capture. To accomplish this, the video capture driver turns on the Drawing Engine Capture Enable bit (DPROE bit 4), selects HOST BLT Read command function (DPROE [3:0]), and enables PCI bus master mode (SCR17 bit 6). The Video Capture Unit loads the incoming video stream into Capture Buffer 1 or 2, depending on which is idle (CPR00 bit 1 or bit 2 = 0 indicates idle status). The Drawing Engine resets Capture Buffer I or Capture Buffer II control/Status bit to 0 (CPR00 bit 1 or bit 2) after a transfer has completed.

Chapter 7: Video Processor

Lynx3DM's Video Processor manages video data streams, as well as graphics data streams in non-VGA modes. The Video Processor can process two independent video data streams. The two video windows (primary and secondary) can be displayed at any screen location with any size, and can be overlaid with graphics data. Lynx3DM also supports Bob and Weave for DVD playback.

Within the Video Processor, the Graphics Source Control block, Video Window I Control block, Video Window II Control block, and HW Pop-up Icon Control block all have independent Starting Address and Offset Address registers. This means that each control block can fetch data from any display memory location. Video Window I source control block supports double-buffered video capture. Internal logic automatically detects the control/status bits of the two capture buffers and fetches the captured video data from the buffer which is not used.

The Video Processor supports TV flicker reduction for direct color modes (64K colors or 16M colors), as well as index color modes (256 colors and 16 colors). A special data path is designed to feed the outputs of the color palette RAM back to the TV Flicker Reduction block. The TV Overscan & Underscan Control block is used to convert 480 lines into 400 visible lines on NTSC TV display. The same function can also be used on PAL TV display. When the TV display is enabled, the Shadow registers need to be locked as 640 x 480 mode (or 720 x 525 for PAL).

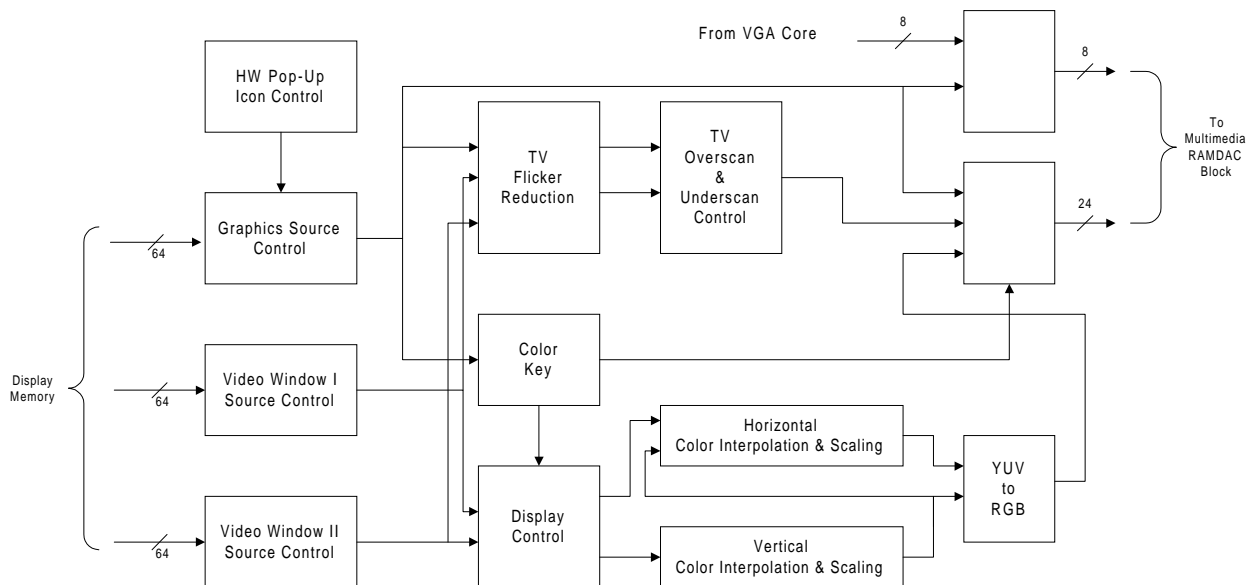

Figure 9: Video Processor Block Diagram

Chapter 8: Zoom Video Port and Video Capture Unit

Zoom Video Port

Lynx3DM's Zoom Video Port (ZV Port) is designed to interface with video solutions implemented as PCMCIA (or PC CardBus) cards: examples are NTSC/PAL decoders, MPEG-2 decoders, and JPEG Codecs. The ZV Port can also directly interface with an NTSC/PAL decoder, such as Philips 7111 or BT819. Figure 10 illustrates an example of the Philips video encoder interface via the ZV Port.

Incoming video data from the ZV Port interface can be YUV or RGB format. The data can be interlaced or non-interlaced. The ZV Port can be configured for output if the video capture function is disabled. 18-bit graphics and video data in RGB format can be sent out when the ZV Port is configured for output mode.

The ZV Port may also be configured as a test port. Up to 20 signals from each of the logic blocks within Lynx3DM can be brought out to an internal test bus (TD Bus) connected to the ZV Port. System designers or silicon validation engineers can access these signals by setting the TEST0, TEST1, USR0, USR1, and USR2 pins. This approach can bring out a total of 180 internal signals to the primary I/O pins. The test port capability can be used to enhance fault coverage, as well as reduce silicon validation or debugging time.

Table 9 lists signal definitions for the following ZV Port interface configurations: YUV input mode, RGB input mode, and graphics/video (output mode).

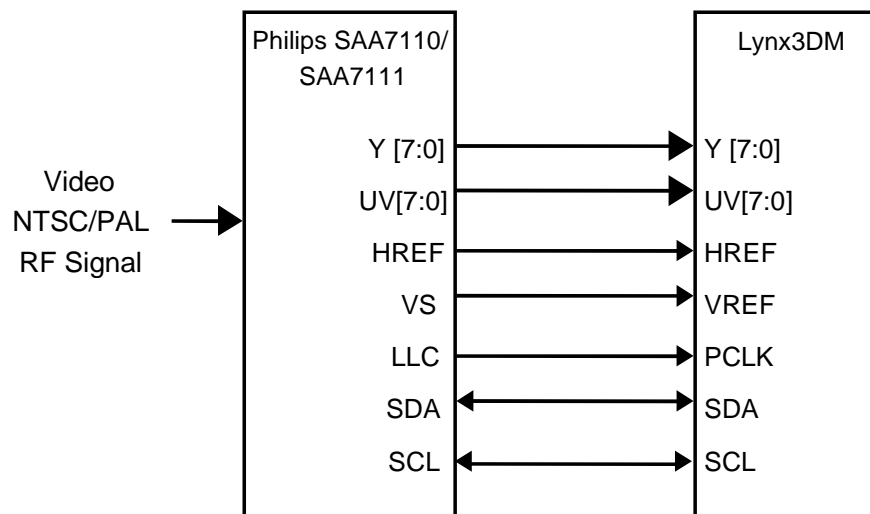

Figure 10: Video Encoder Interface via Video Port

Table 9: Lynx3DM Video Port Interface I/O Compliance

Video Port Interface	ZV Port (Input mode)	I/O	NTSC/PAL Decoder (Input mode)	I/O	Graphics/Video (Output mode)	I/O
VREF	VS	I	VS	I	R7	O
HREF	HREF	I	HREF	I	R6	O
BLANK	(note1)		(note1)		BLANK	O
PCLK	PCLK	I	PCLK	I	PCLK	O
P15	UV7	I	R7	I	R5	O
P14	UV6	I	R6	I	R4	O
P13	UV5	I	R5	I	R3	O
P12	UV4	I	R4	I	R2	O
P11	UV3	I	R3	I	G7	O
P10	UV2	I	G7	I	G6	O
P9	UV1	I	G6	I	G5	O
P8	UV0	I	G5	I	G4	O
P7	Y7	I	G4	I	G3/Vindex_[7]	O
P6	Y6	I	G3	I	G2/Vindex_[6]	O
P5	Y5	I	G2	I	G7/Vindex_[5]	O
P4	Y4	I	B7	I	G6/Vindex_[4]	O
P3	Y3	I	B6	I	G5/Vindex_[3]	O
P2	Y2	I	B5	I	G4/Vindex_[2]	O
P1	Y1	I	B4	I	G3/Vindex_[1]	O
P0	Y0	I	B3	I	G2/Vindex_[0]	O

Note 1: BLANK pin can used as TVCLK output, which is independent of ZV port.

Note 2: Vindex [7:0] is indexed video out

Note 3: SMI test bus is for internal use only

Video Capture Unit

The Video Capture Unit captures incoming video data from the ZV Port and then stores the data into the frame buffer. The Video Capture Unit support several features to maintain display quality, and balance the capture rate:

- 2-tap, 3-tap, and 4-tap horizontal filtering
- 2 to 1 and 4 to 1 reduction for horizontal and vertical frame size
- YUV 4:2:2, YUV 4:2:2 with byte swap, RGB 5:5:5, and RGB 5:6:5
- Multiple frame skipping methods
- Interlaced data and non-interlaced data capture
- Single buffer and double buffer capture
- Cropping

Lynx3DM uses the Video Processor block to display the captured data on the LCD, TV, or CRT display. The captured data can be displayed through Video Window I or Video Window II. The stretching, color interpolation, YUV-to-RGB conversion, and color key functions are performed in the Video Processor. Lynx3DM's Video Processor can simultaneously process captured video data and perform CD-ROM playback on two independent video windows.

Lynx3DM also supports real-time video capture to the hard drive or system memory through PCI master mode or slave mode. In PCI bus master mode, Lynx3DM uses the Drawing Engine's Host BLT and Host DMA functions to maximize performance.

Functional Description

Lynx3DM's Video Capture Unit supports the Video Port Extension (VPE) specification for video stream processing. This capture unit includes CLIP block, FILTER block, SHRINK block, and FIFO control block. Figure 11 and Figure 12 illustrate the Lynx3DM Video Capture Block Diagram and Data Flow. The CLIP functional block is used to select the desired rectangles from the video stream to be captured. VPR40 register (Video Source Clipping Control) is used to define the upper left corner of the rectangle from the video source. VPR44 register (Video Source Capture Size Control) is used to define the height and width of the rectangle from the video source.

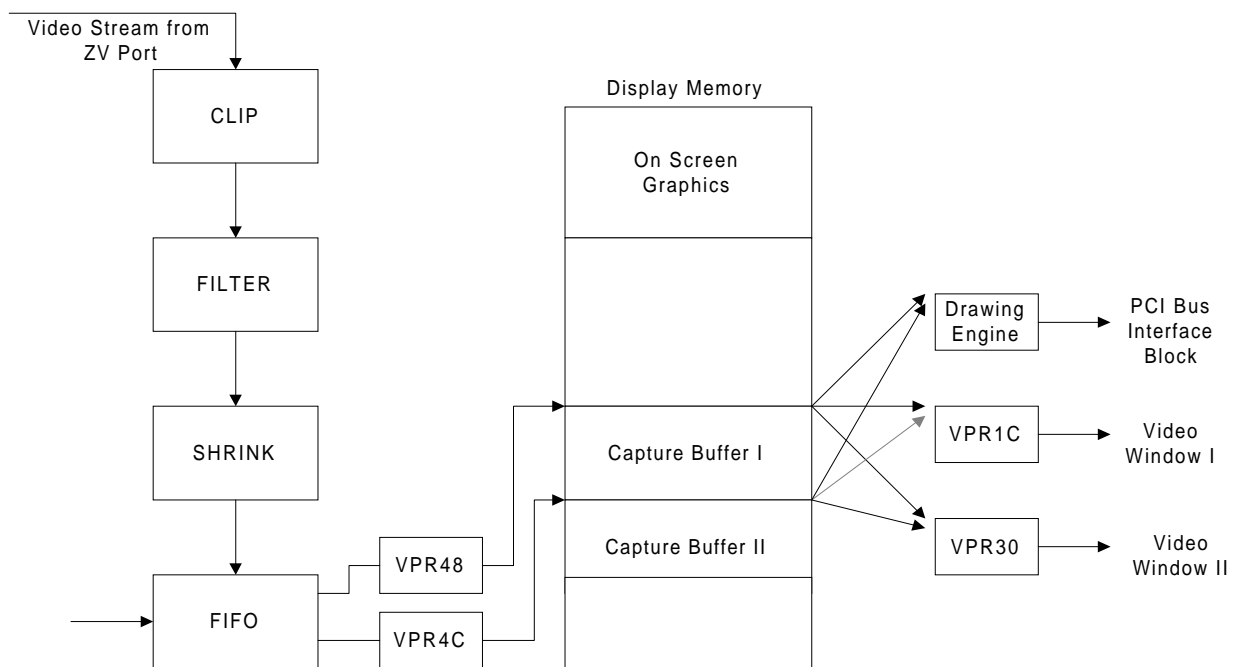

Figure 11: Video Capture Block Diagram

The FILTER functional block controls horizontal filtering logic. CPR00 (Capture Port Control) bit 21 and bit 20 are used to select 2 tap, 3 tap, and 4 tap filtering. The SHRINK functional block is used to not only reduce the storage area for both display memory and hard drive, but also increase performance of video capture and video playback. CPR00 bit 19 and bit 18 are used to enable vertical reduction, and bit 17 and bit 16 are used to enable horizontal reduction. With filter and shrink functions, Lynx3DM is able to achieve high video capture performance and maintain optimal video playback quality.

CPR00 bit 13 to bit 11 are used to select 8 different frame skipping options in the event the capture rate is less than the incoming video stream. CPR00 bit 10 and bit 9 are used to support interlaced capture and double buffer capture. CPR00 bit 1 and bit 2 are used as control/status bits for Buffer I and Buffer II.

The captured data can be displayed on either Video Window I or Video Window II. The video capture driver needs to program VPR1C (or VPR30), Video Window I (or II) Source Start Address, with the same address value from Capture Port Buffer I or II Start Address register. VPR00 (Miscellaneous Graphics and Video Control) bit 24 may be used to automatically display the capture data on Video Window I without programming VPR1C register. This feature is independent of single buffer or double buffer mode.

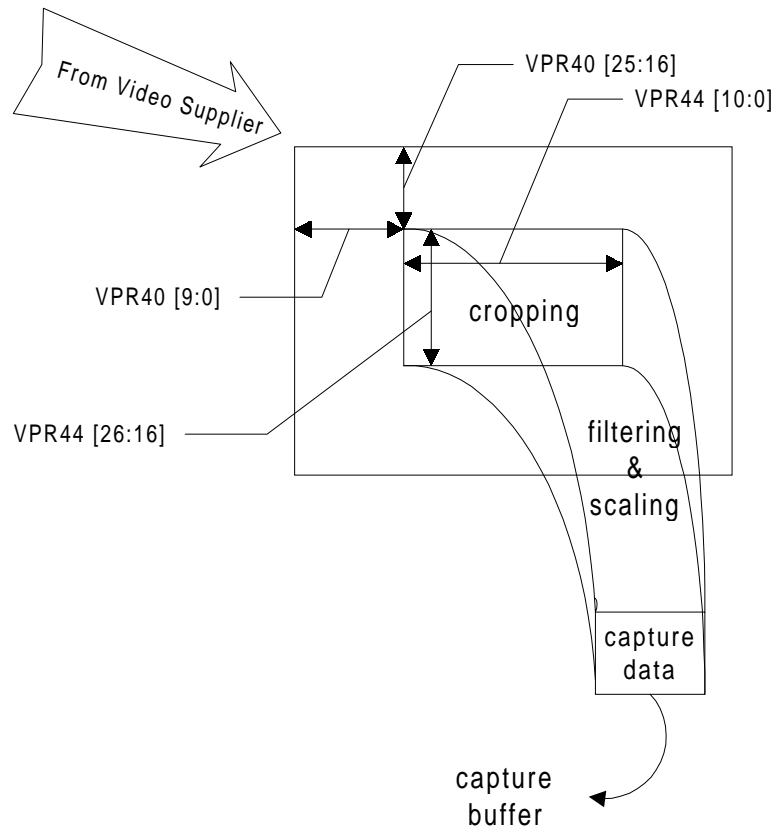

Figure 12: Video Capture Data Flow

Theory of Operation

Initialization

- Enable Video Capture (CPR00 bit 0 = 1)
- Preset Buffer I and Buffer II Status/Control bits (CPR00 [2:1] = 11b)
- Enable Drawing Engine (DPR0E bit 4 = 1)
- Select Host BLT Read Command function (DPR0E [3:0] = 9h)
- Enable PCI bus master mode (SCR17 bit 6 = 1)
- Select Field Detection, VREF/HREF polarity, Vertical/Horizontal Reduction, Horizontal Filtering, Video Capture Input Data Format, Frame Skip, Interlaced/non-interlaced and other miscellaneous settings (CPR00, Capture Port Control Register)

Table 10: Bit Setting Summary for Video Capture

B1S	Buffer 1 Status/Control (CPR00 bit 1)
B2S	Buffer 2 Status/Control (CPR00 bit 2)
Continuous Capture	bit 8 = 0
Conditional Capture	bit 8 = 1
Single Buffer	bit 9 = 0
Double Buffer	bit 9 = 1
Non-interlaced Mode	bit 10 = 0
Interlaced Mode	bit 10 = 1

The Video Capture Unit supports the following types of capture modes:

- Single Buffer Mode with Continuous Capture
- Single Buffer Mode with Conditional Capture
- Double Buffer Mode with Continuous Capture
- Double Buffer Mode with Conditional Capture
- Interlace and Non-Interlaced Mode

A summary of each of the video capture modes follows:

- **Single Buffer Mode with Continuous Capture**

Video Capture Unit (VCU)	Drawing Engine (DE)	Video Processor (VP)
<ul style="list-style-type: none"> • Continuously capture incoming video data to capture buffer 1 • Independent of B1S and B2S bits 	It is not recommended to use the Drawing Engine to transfer captured data from display memory to hard drive or system memory in this mode. This mode is used to view the captured data only.	<ul style="list-style-type: none"> • VPR00 bit 24 = 0 Captured data can be displayed on either Video Window I or Video Window II by setting video window start address register. • VPR00 bit 24 = 1 Captured data is automatically displayed on Video Window I.

- **Single Buffer Mode with Conditional Capture**

Video Capture Unit (VCU)	Drawing Engine (DE)	Video Processor (VP)
a) VCU monitors B1S bit b) If B1S = 1, start capture c) VCU will reset B1S to 0 after it completes a frame d) Go to step "a"	a) Test b) If B1S = 0, SW will activate the DE to transfer captured data from capture buffer 1 to hard drive or system memory c) DE will set B1S bit to 1 after it completes a frame d) Go to step "a"	<ul style="list-style-type: none"> • VPR00 bit 24 = 0 Captured data can be displayed on either Video Window I or Video Window II by setting video window start address register. • VPR00 bit 24 = 1 Captured data is automatically displayed on Video Window I

• **Double Buffer Mode with Continuous Capture**

Video Capture Unit (VCU)	Drawing Engine (DE)	Video Processor (VP)
<ul style="list-style-type: none"> Continuously capture the incoming video data into capture buffer 1 or buffer 2 Automatically switch from one buffer to the other when VCU completes a frame Independent of B1S and B2S bits 	<p>It is not recommended to use DE to transfer captured data from display memory to hard drive or system memory in this mode. This mode is used to view the captured data only.</p>	<ul style="list-style-type: none"> VPR00 bit 24 = 0 Captured data can be displayed on either Video Window I or Video Window II by setting video window start address register. VPR00 bit 24 = 1 Captured data is automatically displayed on Video Window I. If capture buffer 1 is used by VCU, Video Window I will display captured data from capture buffer 2

• **Double Buffer Mode with Conditional Capture**

Video Capture Unit (VCU)	Drawing Engine (DE)	Video Processor (VP)
<ul style="list-style-type: none"> a) VCU monitors B1S and B2S bits b) If B1S (or B2S) = 1, start video capture and store into capture buffer 1 (or buffer 2). c) VCU will reset B1S (or B2S) to 0 after it completes a frame d) VCU will continue video capture if B1S or B2S = 1 e) Go to step "a" if both bits = 0 	<ul style="list-style-type: none"> a) SW monitors B1S or B2S bit b) If B1S (or B2S) = 0, SW will activate the DE to transfer captured data from capture buffer 1(or buffer 2) to hard drive or system memory c) DE will set B1S (or B2S) bit to 1 after it completes a frame d) DE will continuously transfer Data from capture buffer 1 or 2 if B1S or B2S = 0 e) Go to step "a " if both bits = 1 	<ul style="list-style-type: none"> VPR00 bit 24 = 0 Captured data can be displayed on either Video Window I or Video Window II by setting video window start address register. VPR00 bit 24 = 1 Captured data is automatically displayed on Video Window I. If capture buffer 2 is used by VCU, Video Window I will display captured data from capture buffer 1.

• **Interlaced Capture**

CPR00 bits 10 are used to select the interlaced capture mode. In most of video capture applications, an interlaced video stream will be treated as non-interlaced video stream by dropping all even frames (CPR00[13:11] = 010b), or dropping all odd frames (CPR00[13:11] = 011). This approach will reduce artifacts when playing back the captured data. However, in some video capture applications, de-interlacing is needed to handle the incoming interlaced video stream.

For the de-interlacing case, CPR00 bit 10 needs to be set to 1 to enable interlaced capture for incoming interlaced video stream. The double buffer mode (CPR00 bit 9 = 1) needs to be turned on at the same time. Capture Buffer 1 and Capture Buffer 2 are combined together as a single buffer with one line offset. Figure 13 illustrates the capture buffer structure. The video capture driver will preset B1S and B2S bits to 1 to initialize the buffer 1 and 2 status/control bits. The Video Capture Unit will start video capture if any one of B1S and B2S = 1. After VCU fills capture buffer 1 and 2, both B1S and B2S bits are set to "0" by VCU. The video capture driver will activate Drawing Engine to transfer captured data in capture buffer 1 and 2 to system memory or hard drive when both B1S and B2S are "0". After the completion of the transfer, the Drawing Engine will set both B1S and B2S to "1". The Video Capture Unit then continues video capture and repeats the same protocol.

During video playback, the captured data can be displayed on either Video Window I or Video Window II. It is not recommended to display both even frame and odd frame for video playback. The video captured driver can program Video Window I (or II) Source Start Address Register and Video Window I (or II) Source Width and Offset Register in such a way that odd frame (or even frame) captured data will be dropped during video playback. The scaling, color interpolation, and YUV-to-RGB conversion functions can also be enabled at the same time.

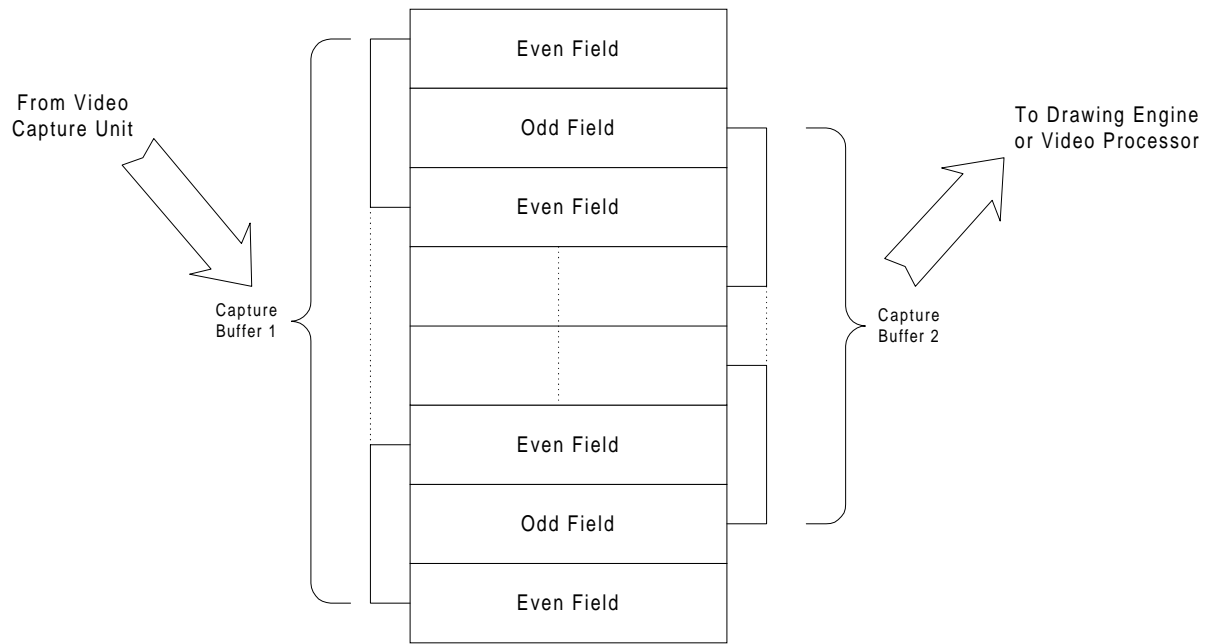

Figure 13: Capture Buffer Structure in Interlaced Mode

Chapter 9: Flat Panel Interface

Lynx3DM supports both color dual scan STN (passive) and color TFT (active) panel interface for notebook computers. It can also support color TFT panel with RGB analog interface. For color DSTN panel, Lynx3DM can support 16-bit and 24-bit interfaces up to 1600x1200 resolution. For color TFT panel, Lynx3DM can support single pixel per clock of 9-bit, 12-bit, 18-bit, 24-bit, or double-pixel per clock of 24-bit, 36-bit and 48-bit interfaces up to 1400x1050 resolution. Table 11 lists the complete set of Lynx3DM panel interface pins for both color DSTN and TFT LCD. Figure 15 shows the single-pixel per clock TFT interface, Figure 16 shows the double-pixel per clock TFT interface, Figure 18 shows the 16-bit DSTN interface, and Figure 19 shows the 24-bit DSTN interface.

Lynx3DM Flat Panel Enhancements

Lynx3DM integrates various flat panel enhancement features such as: LCD screen auto-centering, LCD screen expansion (including XY interpolated screen expansion), Virtual Refresh, and special dithering engines for TFT and DSTN flat panels.

Lynx3DM Flat Panel Enhancements

Lynx3DM integrates various flat panel enhancement features such as: LCD screen auto-centering, LCD screen expansion (including XY interpolated screen expansion), Virtual Refresh, and special dithering engines for TFT and DSTN flat panels.

Lynx3DM Graphics/Text Expansion Information

Introduction

Lynx3DM provides full expansion capability for text and graphics modes. Text as well as graphics expansion is supported up to XGA resolution. Expansion is supported on TFT and DSTN panels. A detailed description of the expansion algorithms of these devices follows:

Horizontal Expansion for Text and Graphics

Horizontal expansion is handled in 8 pixel pieces whether the mode is text or graphics. There are two expansion mechanisms: 10-dot expansion and 12-dot expansion. 10-dot expansion is used to expand to 800 pixels, 12-dot is used to expand to 960 pixels for XGA panel sizes.

For 10-dot expansion, every 4th pixel is duplicated. For example, for mode3h (80x25 text) or mode 12h(640x480 graphics), where p0 is pixel one and p7 is pixel 8 - p0p1p2**p3**p3p4p5p6**p7p7** - the 4th pixel (p3) is duplicated, as well as the 8th pixel (p7). The pattern repeats for each 8 pixel piece.

For 12-dot expansion, every other pixel, beginning with p1 is duplicated. For example, for mode 3h or mode 12h - p0**p1**p1p2**p3**p3p4**p5**p5p6**p7**p7. Again, the pattern repeats for each pixel piece.

So far, all examples assume 8x16 font size. There is also 9x16 font size to consider (in this case the actual font is still 8x16, but an additional 9th dot - either the background color or a repeat of the 8th pixel - is inserted). For 9x16 case, pixel

p3 is duplicated just like 8x16 case. Pixel p7 is handled somewhat differently depending on whether the character is a text character or graphics character - for text character case, the second p7 value becomes the background color. For graphics case, p7 is repeated.

Vertical Expansion for Text and Graphics

Vertical expansion for text or graphics uses a Dynamic Duplication Algorithm (DDA) method to achieve expansion. The same basic methodology is used independent of resolution. First, an initial DDA constant value (for Lynx3DM this is a 10-bit value) is loaded into the Vertical Screen Expansion DDA Constant Registers. This value is used as part of a logical algorithm to determine which lines on the display to duplicate. Figure 14 is a diagram of the algorithm.

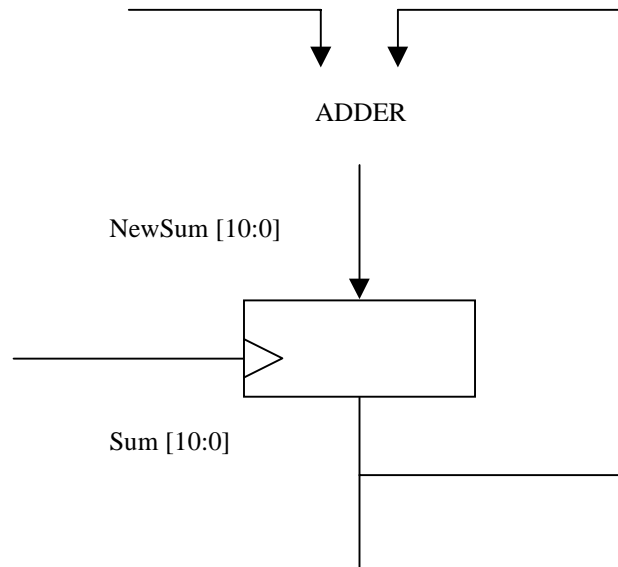

Figure 14: DDA Expansion Algorithm

For each line of the display, the following equation is calculated via the illustrated algorithm:

$$\text{NewSum [10:0]} = \text{Sum[10:0]} + \text{DDA}$$

If $\text{Sum [10:0]} = \text{NewSum [10:0]}$, the given line is duplicated.

For text case, the DDA logic algorithm will reset each character block, so expansion is handled in terms of character rows (e.g. 25 character rows of 16 lines each). For the graphics case, the DDA logic algorithm will reset when the bottom of the display is reached.

The DDA constant may be calculated by the following equation:

$$\frac{1024}{\text{DDA}} = \frac{\text{Expanded Resolution}}{\text{Existing Resolution}}$$

For example, to expand a 480 line mode to 768, the equation would be:

$$\frac{1024}{\text{DDA}} = \frac{768 \text{ Lines}}{480 \text{ Lines}}$$

DDA constant may then be calculated and entered into the expansion algorithm.

DDA[9:0]

LCD Dithering Engine

Lynx3DM has separate dithering engines for color DSTN LCD and color TFT LCD. The DSTN dithering engine includes a set of 32 different dithering patterns which are developed with LCD's response time and contrast ratio in mind. FPR32 bit 5 is used to select 16 gray levels or 32 gray levels for each Red, Green, and Blue color. The TFT dithering engine includes a set of 8 different dithering patterns which combine frame rate modulation and space dithering algorithm. FPR32 bit 7 and 6 are used to select 4-gray level dithering, 8-gray level dithering, and no dithering.

Flat Panel Power ON/OFF Sequencing

Lynx3DM integrates logic for panel power ON/OFF sequencing during power down modes and display switching.

There are two ways to power ON/OFF the flat panel: hardware panel power sequencing and software panel power sequencing.

Hardware panel power sequencing:

Hardware panel power sequencing is selected when FPR34 bit 7 = 1. Whenever FPR31 bit toggles, Lynx3DM automatically controls LCD data, LCD controls, FPEN, FPVDD, and VBIASEN pins. FPR33 [3:2] determines the time period from FPEN to VBIASEN, from VBIASEN to LCD controls/data, and from LCD controls/data to FPVDDEN.

FPR33[3:2]	Power On Sequencing Time Select
00	1 vertical frame
01	2 vertical frames
10	4 vertical frames
11	8 vertical frames

Figure 20 shows the auto panel power on sequencing timing relationship. Figure 21 shows the auto panel power off sequencing timing relationship.

For flat panels which have non-standard requirements for on/off power sequencing, Lynx3DM supports panel power on/off sequencing through software programming.

Below are examples of software programming for panel power on sequencing:

Software panel power sequencing- ON:

- Set FPR34 bit 7 = 0 (software panel power sequencing)
- Setup shadow registers: SVR40 to SVR4B
- Set FPR31 bit 0 = 1 (enable LCD display)
- After X vertical frames, set PDR22 bit 0 = 1 (turn on FPVDDEN)
- After X vertical frames, set PDR22 bit 1 = 0 (enable LCD controls and data)
- After X vertical frame, set PDR22 bit 2 = 1 (turn on VBIASEN)
- After X vertical frames, set PDR22 bit 3 = 1 (turn on FPEN)

Note: LCD backlight control is independent of power sequencing. The VBKLGT can be turned on at the same time as FPEN.

Software panel power sequencing - OFF:

- Set FPR34 bit 7 = 0 (software panel power sequencing)
- Select FPR33 [3:2] for panel power on/off timing:
- Set PDR22 bit 3 = 0 (turn off FPEN)
- After X vertical frames, set PDR22 bit 2 = 0 (turn off VBIASEN)
- After X vertical frames, set PDR22 bit 1 = 1 (disable LCD controls and data)
- After X vertical frames, set PDR22 bit 0 = 0 (turn off FPVDDEN)
- Set FPR31 bit 0 = 0 (disable LCD display)

Lynx3DM Dual Digital LCD Support

Lynx3DM can support two separate digital LCDs. Both LCDs need to be TFT interface. FP1 has to be only 18-bit TFT interface and FP2 has to be 24-bit TFT interface. DSTN panel can not be supported under dual digital LCD mode.

Table 11 lists the Dual Digital LCD pin mapping for FP1 + FP2.

Dual Digital LCD mode is supported through the Virtual Refresh architecture. FP1 and FP2 must be in Virtual Refresh mode. FP1 clocks the data based on VRCLK (Virtual Refresh Clock); whereas FP2 clocks the data based on WFIFOCLK (based on Video Clock).

To enable FP1 + FP2, the following registers need to be programmed:

- * FPR31[7] = 1 (virtual refresh enable)
- * FPR4E[1] = 1 (enable second LCD panel)
- * PDR21[5] = 0 (enable LCD frame buffer write)
- * CCR69[5] = 1 (LVDSCLK source is from inverted WFIFO clock)

FP1's timing can be programmed via the Virtual Refresh Timing Registers. (FPR50 - FPR57) FP2's timing is directly derived from the CRT timing under Virtual Refresh mode via the Shadow VGA Registers (SVR40 - SVR4D).

Lynx3DM Flat Panel Interface Connections

Lynx3DM supports both color dual scan STN (passive) and TFT (active) panel interface for notebook computers. It supports DSTN in 16-bit 24-bit interface. For TFT interface, it can support either 9-bit, 12-bit, 18-bit, 24-bit, 12-bitx2, 18-bitx2, and 24-bitx2. Furthermore, Lynx3DM can support two separate TFT interface: FP1 is 18-bit TFT and FP2 is 24-bit TFT. The table listed below details the various pin mapping for different panel configuration

Table 11: Flat Panel Interface Pins listing for color DSTN and color TFT LCD

Pin Name	DSTN		TFT					
	16-bit	24-bit	9-bit	12-bit	18-bit	24-bit	12-bit x2	18-bit x2
LP/FHSYNC	LP	LP	HSYNC	HSYNC	HSYNC	HSYNC	HSYNC	HSYNC
FP/FVSYNC	FP	FP	VSYNC	VSYNC	VSYNC	VSYNC	VSYNC	VSYNC
FPCLK	XCK	XCK	CK	CK	CK	CK	CK	CK
DE			ENAB	ENAB	ENAB	ENAB	ENAB	ENAB
FPEN	FPEN	FPEN	FPEN	FPEN	FPEN	FPEN	FPEN	FPEN
FPVDDEN	VDD	VDD	VDD	VDD	VDD	VDD	VDD	VDD
VBIASEN	VEE	VEE	VEE	VEE	VEE	VEE	VEE	VEE
FPDATA35								RB5
FPDATA34								RB4
FPDATA33								RA5
FPDATA32								RA4
FPDATA31								GB5
FPDATA30								GB4
FPDATA29								GA5
FPDATA28								GA4
FPDATA27								BB5
FPDATA26								BB4
FPDATA25								BA5
FPDATA24								BA4
FPDATA23		UD11				R7	RB3	RB3
FPDATA22		UD10				R6	RB2	RB2
FPDATA21		UD9			R5	R5	RB1	RB1
FPDATA20		UD8			R4	R4	RB0	RB0
FPDATA19	UD7	UD7		R3	R3	R3	RA3	RA3
FPDATA18	UD6	UD6	R2	R2	R2	R2	RA2	RA2
FPDATA17	UD5	UD5	R1	R1	R1	R1	RA1	RA1
FPDATA16	UD4	UD4	R0	R0	R0	R0	RA0	RA0
FPDATA15	UD3	UD3				G7	GB3	GB3

Table 11: Flat Panel Interface Pins listing for color DSTN and color TFT LCD

Pin Name	DSTN		TFT					
	16-bit	24-bit	9-bit	12-bit	18-bit	24-bit	12-bit x2	18-bit x2
FPDATA14	UD2	UD2				G6	GB2	GB2
FPDATA13	UD1	UD1			G5	G5	GB1	GB1
FPDATA12	UD0	UD0			G4	G4	GB0	GB0
FPDATA11		LD11		G3	G3	G3	GA3	GA3
FPDATA10		LD10	G2	G2	G2	G2	GA2	GA2
FPDATA9		LD9	G1	G1	G1	G1	GA1	GA1
FPDATA8		LD8	G0	G0	G0	G0	GA0	GA0
FPDATA7	LD7	LD7				B7	BB3	BB3
FPDATA6	LD6	LD6				B6	BB2	BB2
FPDATA5	LD5	LD5			B5	B5	BB1	BB1
FPDATA4	LD4	LD4			B4	B4	BB0	BB0
FPDATA3	LD3	LD3		B3	B3	B3	BA3	BA3
FPDATA2	LD2	LD2	B2	B2	B2	B2	BA2	BA2
FPDATA1	LD1	LD1	B1	B1	B1	B1	BA1	BA1
FPDATA0	LD0	LD0	B0	B0	B0	B0	BA0	BA0

Pin name	24-bitx2 TFT	TFTs: FP1 + FP2	18-bit x2 TFT	24-bit TFT
DE	DE	FP1_DISP	DE	DE
FP_FVSYNC	FP_FVSYNC	FP1_FVSYNC	FP_FVSYNC	FP_FVSYNC
LP_FHSYNC	LP_FHSYNC	LP1_FHSYNC	LP_FHSYNC	LP_FHSYNC
FPCLK	FPCLK	FP1_SCLK	FPCLK	FPCLK
FPEN	FPEN	FPEN	FPEN	FPEN
FPVDDEN	FPVDDEN	FPVDDEN	FPVDDEN	FPVDDEN
VBIASEN	VBIASEN	VBIASEN	VBIASEN	VBIASEN
FPDATA47	RB7	FP2_R7		
FPDATA46	RB6	FP2_R6		
FPDATA45	RA7	FP2_R5		
FPDATA44	RA6	FP2_R4		
FPDATA43	GB7	FP2_R3		
FPDATA42	GB6	FP2_R2		
FPDATA41	GA7	FP2_R1		
FPDATA40	GA6	FP2_R0		
FPDATA39	BB7	FP2_G7		

Pin name	24-bitx2 TFT	TFTs: FP1 + FP2	18-bit x2 TFT	24-bit TFT
FPDATA38	BB6	FP2_G6		
FPDATA37	BA7	FP2_G5		
FPDATA36	BA6	FP2_G4		
FPDATA35	RB5	FP2_G3	RB5	
FPDATA34	RB4	FP2_G2	RB4	
FPDATA33	RA5	FP2_G1	RA5	
FPDATA32	RA4	FP2_G0	RA4	
FPDATA31	GB5	FP2_B7	GB5	
FPDATA30	GB4	FP2_B6	GB4	
FPDATA29	GA5	FP2_B5	GA5	
FPDATA28	GA4	FP2_B4	GA4	
FPDATA27	BB5	FP2_B3	BB5	
FPDATA26	BB4	FP2_B2	BB4	
FPDATA25	BA5	FP2_B1	BA5	
FPDATA24	BA4	FP2_B0	BA4	
FPDATA23	RB3	FP2_VSYNC	RB3	R7
FPDATA22	RB2	Fp2_HSYNC	RB2	R6
FPDATA21	RB1	FP1_R5	RB1	R5
FPDATA20	RB0	FP1_R4	RB0	R4
FPDATA19	RA3	FP1_R3	RA3	R3
FPDATA18	RA2	FP1_R2	RA2	R2
FPDATA17	RA1	FP1_R1	RA1	R1
FPDATA16	RA0	FP1_R0	RA0	R0
FPDATA15	GB3	FP2_DE	GB3	G7
FPDATA14	GB2		GB2	G6
FPDATA13	GB1	FP1_G5	GB1	G5
FPDATA12	GB0	FP1_G4	GB0	G4
FPDATA11	GA3	FP1_G3	GA3	G3
FPDATA10	GA2	FP1_G2	GA2	G2
FPDATA9	GA1	FP1_G1	GA1	G1
FPDATA8	GA0	FP1_G0	GA0	G0
FPDATA7	BB3		BB3	B7
FPDATA6	BB2		BB2	B6
FPDATA5	BB1	FP1_B5	BB1	B5
FPDATA4	BB0	FP1_B4	BB0	B4

Pin name	24-bitx2 TFT	TFTs: FP1 + FP2	18-bit x2 TFT	24-bit TFT
FPDATA3	BA3	FP1_B3	BA3	B3
FPDATA2	BA2	FP1_B2	BA2	B2
FPDATA1	BA1	FP1_B1	BA1	B1
FPDATA0	BA0	FP1_B0	BA0	B0
LVDSCCLK		FP2_SCLK		

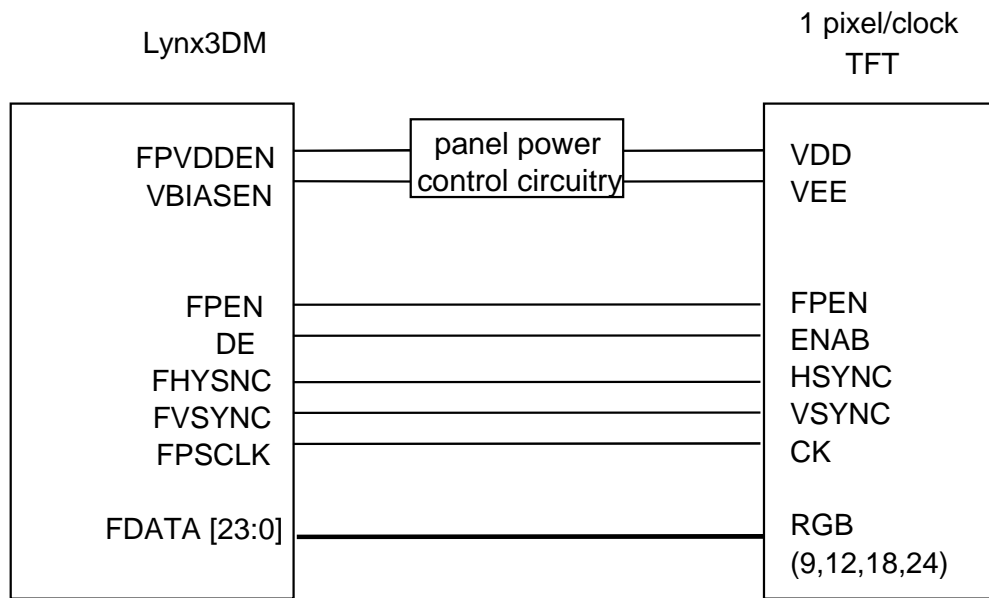

Figure 15: TFT (Single Pixel/Clock) Interface Diagram

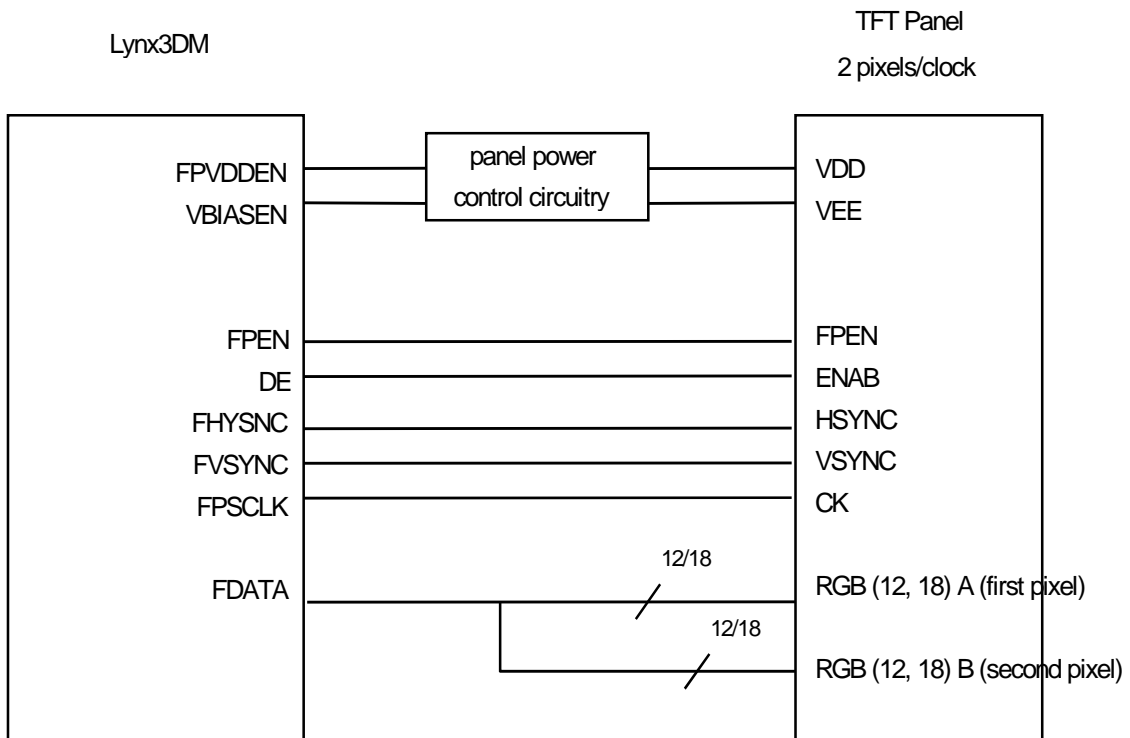

Figure 16: TFT Panel (2 pixels/clock) Interface Diagram

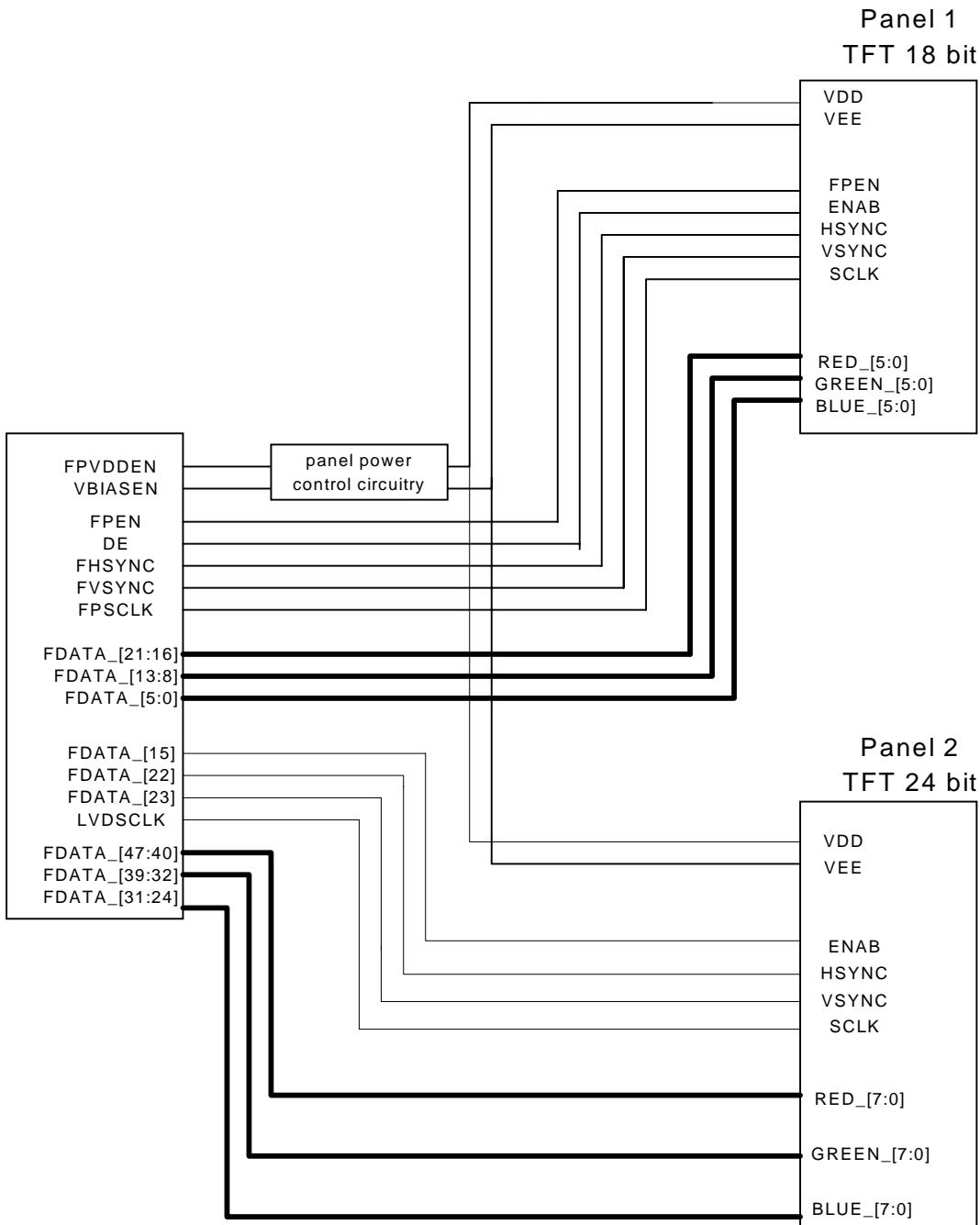

Figure 17: TFT Two Panel Interface Diagram

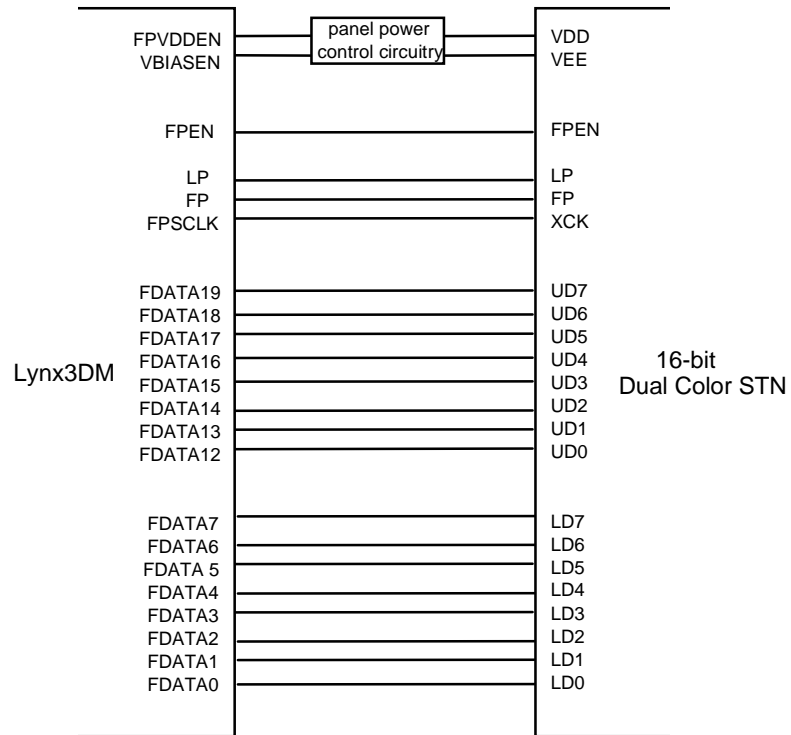

Figure 18: 16-bit DSTN Interface Configuration

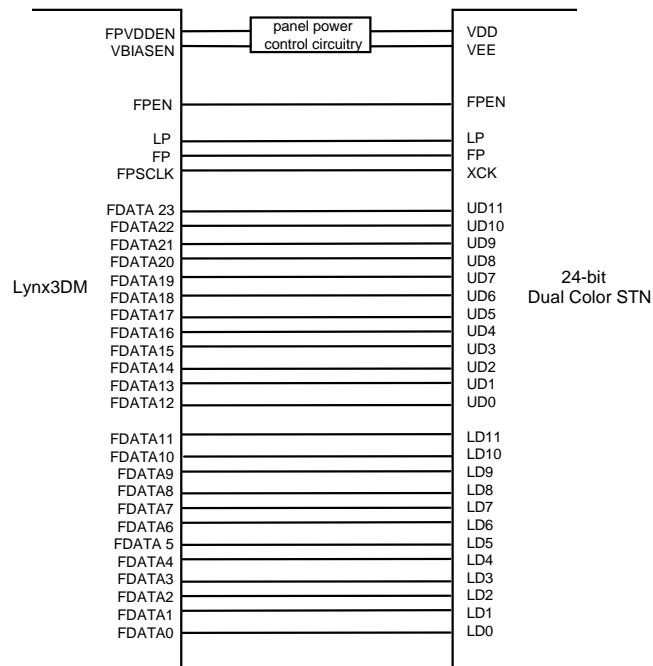
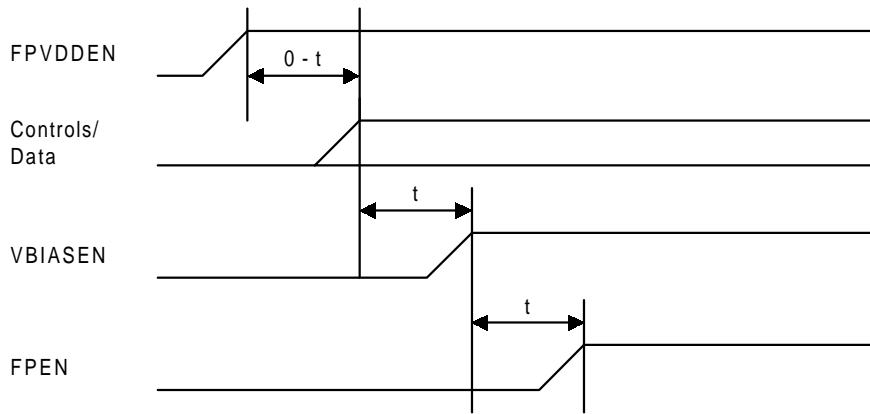
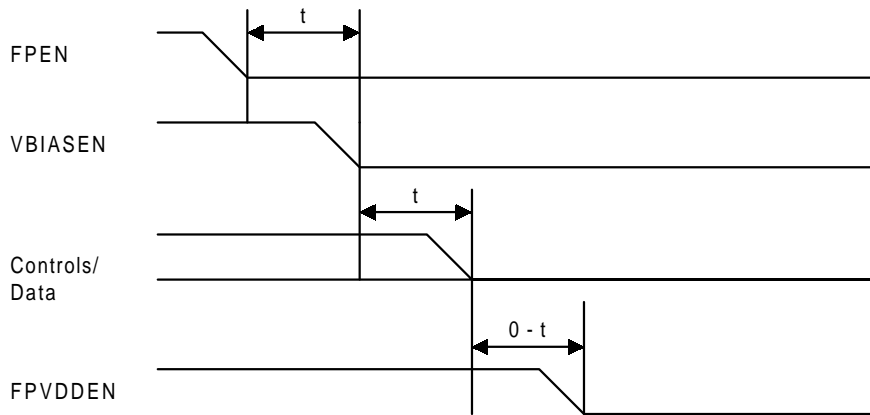

Figure 19: 24-bit Dual Color STN Interface Diagram



t is programmed via FPR33 [3:2]

Figure 20: Panel Power On Sequencing Timing Diagram



t is programmed via FPR33 [3:2]

Figure 21: Panel Power Off Sequencing Timing Diagram

FPR33[3:2]	Power On/Off Sequencing Time Select
00	1 vertical frame
01	2 vertical frames
10	4 vertical frames
11	8 vertical frames

LVDS Chipset Interface

In order to address EMI and cable issues associated with a wide, high speed TTL/CMOS panel interface, designers may choose to use an LVDS (Low Voltage Differential Signaling) chipset or a PanelLink chipset (each chipset type includes a transmitter and a receiver). Examples of the LVDS chipset include National Semiconductor DS90C383/4 (3.3V, 65 MHz) or Texas Instruments' SN75LVDS83/2 (3.3V, 65 MHz); the chipsets from these vendors are pin-compatible. The PanelLink chipset is available from Silicon Image (SiI100). Lynx3DM supports a direct interface to the transmitter of either LVDS or PanelLink chipset types. Figure 22 and Figure 23 illustrate the 24-bit interfaces for TFT and DSTN LVDS panels. Figure 25 and Figure 26 illustrate the 24-bit interfaces for TFT and DSTN PanelLink panels. For 36-bit LVDS interface (2 channel LVDS), please refer to Figure 24.

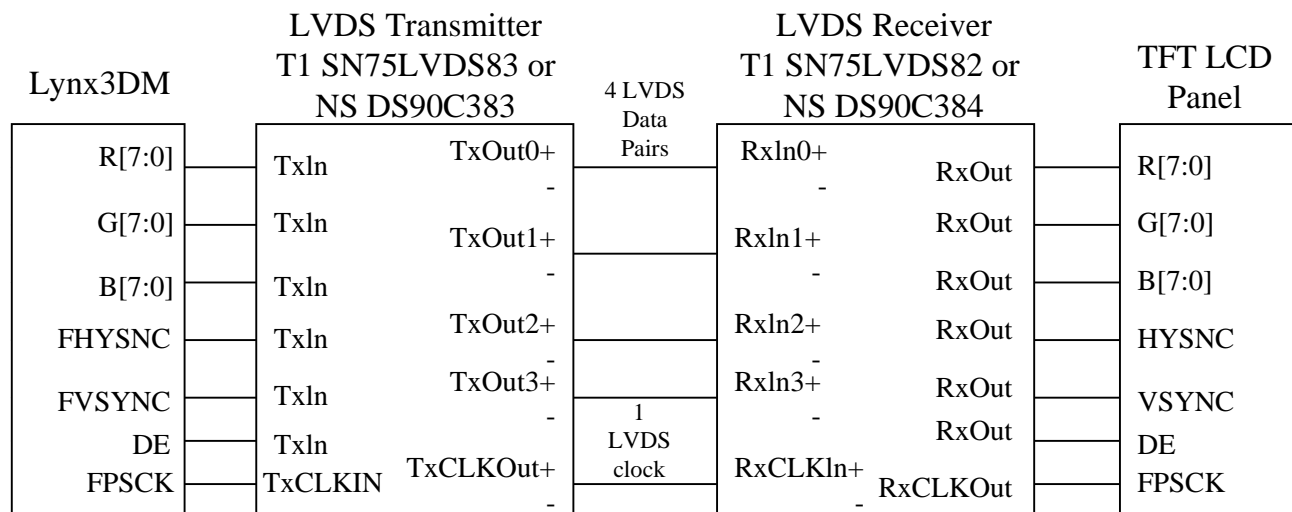

Figure 22: LVDS Interface with TFT LCD Panel

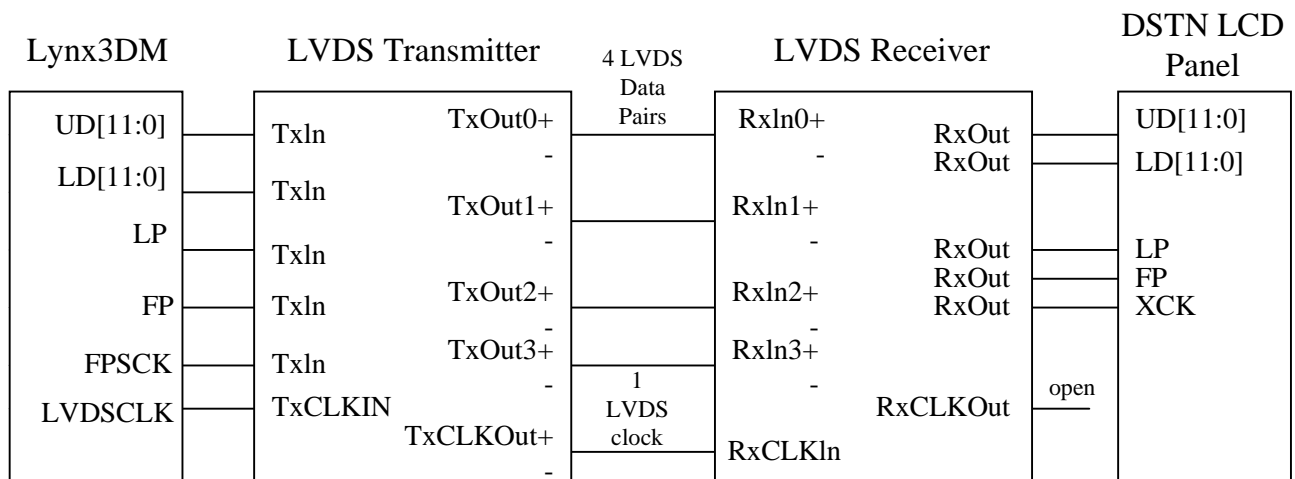

Figure 23: LVDS Interface with DSTN LCD Panel

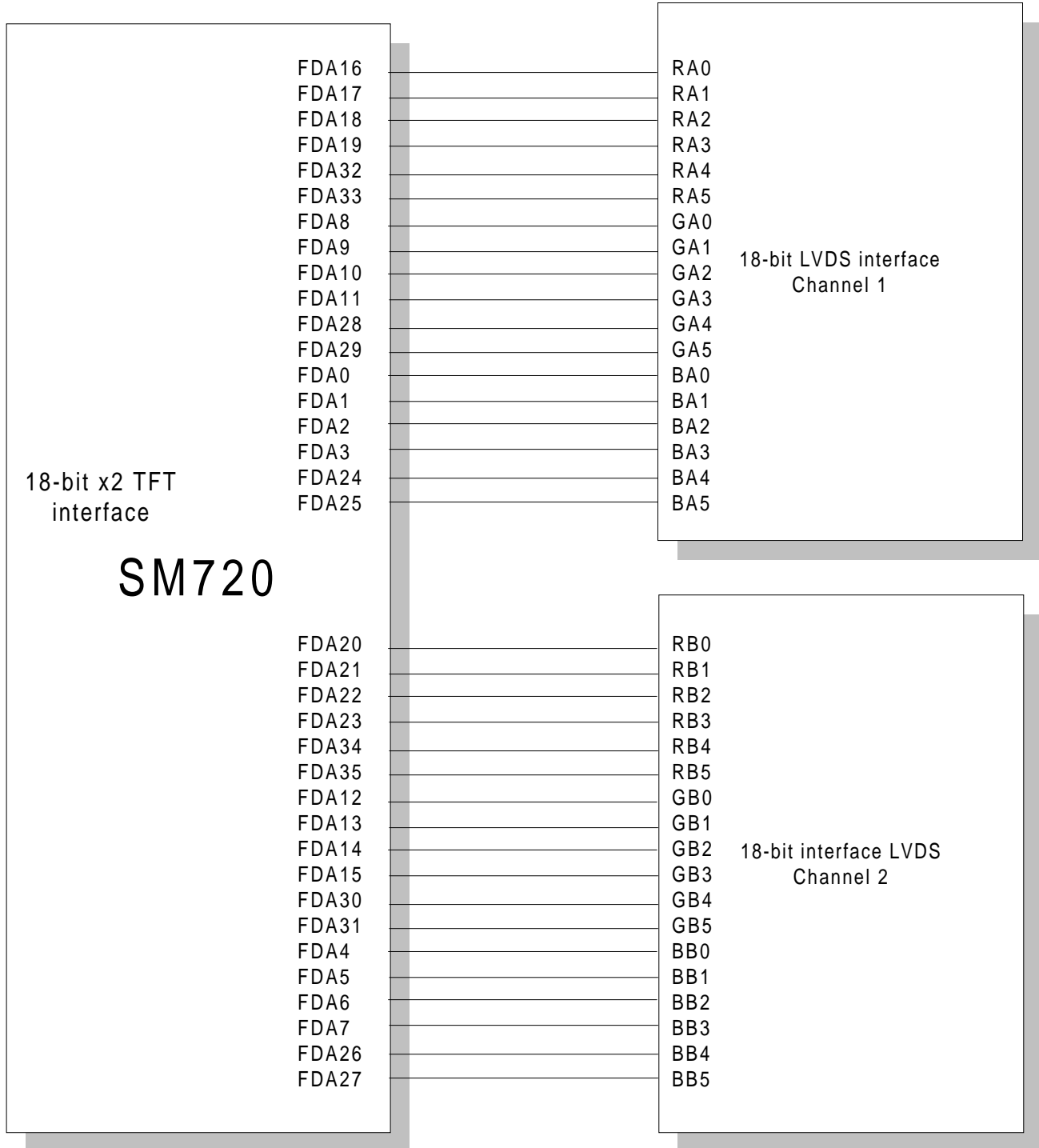

Figure 24: 36-bit (18x2 bit) TFT Interface Diagram

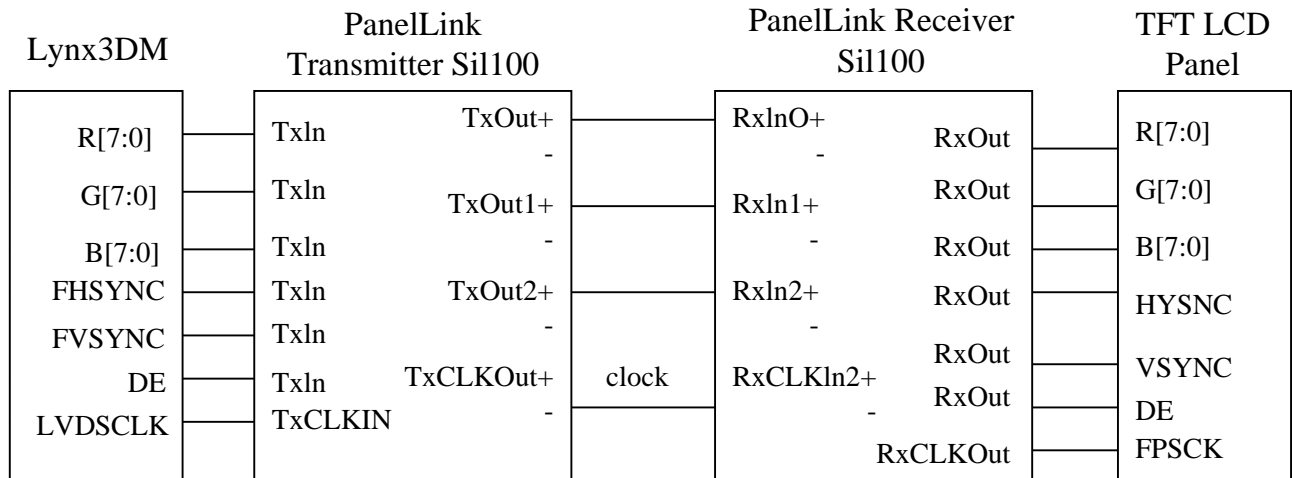

Figure 25: PanelLink Interface with TFT LCD Panel

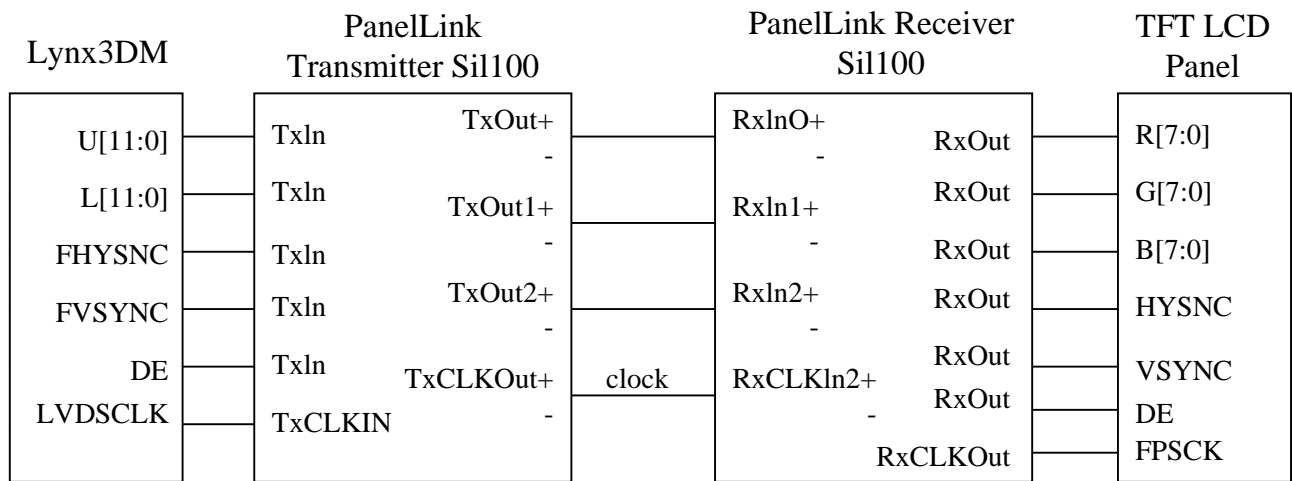

Figure 26: PanelLink Interface with DSTN LCD Panel

Table 12 and Table 13 list the pin mapping for an LVDS transmitter with Lynx3DM for LVDS TFT and DSTN panels. Table 14 and Table 15 list the pin mapping for a PanelLink transmitter with Lynx3DM for PanelLink TFT and DSTN panels.

Please consult your panel manufacturer to verify the pin mapping between the LVDS receiver and the panel. The pin mapping from the transmitter side must correspond with the pin mapping from the receiver side in order to ensure that the panel will function properly.

Table 12: LVDS Transmitter Pin Mapping for TFT Interface

Lynx3DM Pin Name	TFT interface	LVDS Transmitter SN75LVDS83/DS90C383 Pin #	LVDS Transmitter Pin Name
FPDATA16	R0	51	TxIN0
FPDATA17	R1	52	TxIN1
FPDATA18	R2	54	TxIN2
FPDATA19	R3	55	TxIN3
FPDATA20	R4	56	TxIN4
FPDATA21	R5	3	TxIN6
FPDATA22	R6	50	TxIN27
FPDATA23	R7	2	TxIN5
FPDATA8	G0	4	TxIN7
FPDATA9	G1	6	TxIN8
FPDATA10	G2	7	TxIN9
FPDATA11	G3	11	TxIN12
FPDATA12	G4	12	TxIN13
FPDATA13	G5	14	TxIN14
FPDATA14	G6	8	TxIN10
FPDATA15	G7	10	TxIN11
FPDATA0	B0	15	TxIN15
FPDATA1	B1	19	TxIN18
FPDATA2	B2	20	TxIN19
FPDATA3	B3	22	TxIN20
FPDATA4	B4	23	TxIN21
FPDATA5	B5	24	TxIN22
FPDATA6	B6	16	TxIN16
FPDATA7	B7	18	TxIN17
LP/FHSYNC	FHSYNC	27	TxIN24
FP/FVSYNC	FVSYNC	28	TxIN25
DE	DE	30	TxIN26
-	-	25	TxIN23
FPCLK	FPCLK	31	TxCLKIN

Table 13: LVDS Transmitter Pin Mapping for DSTN Interface

Lynx3DM Pin Name	STN interface	LVDS Transmitter SN75LVDS83/DS90C383 Pin #	LVDS Transmitter Pin Name
FPDATA12	UD0	12	TxIN13
FPDATA13	UD1	14	TxIN14
FPDATA14	UD2	8	TxIN10
FPDATA15	UD3	10	TxIN11
FPDATA16	UD4	51	TxIN0
FPDATA17	UD5	52	TxIN1
FPDATA18	UD6	54	TxIN2
FPDATA19	UD7	55	TxIN3
FPDATA20	UD8	56	TxIN4
FPDATA21	UD9	3	TxIN6
FPDATA22	UD10	50	TxIN27
FPDATA23	UD11	2	TxIN5
FPDATA0	LD0	15	TxIN15
FPDATA1	LD1	19	TxIN18
FPDATA2	LD2	20	TxIN19
FPDATA3	LD3	22	TxIN20
FPDATA4	LD4	23	TxIN21
FPDATA5	LD5	24	TxIN22
FPDATA6	LD6	16	TxIN16
FPDATA7	LD7	18	TxIN17
FPDATA8	LD8	4	TxIN7
FPDATA9	LD9	6	TxIN8
FPDATA10	LD10	7	TxIN9
FPDATA11	LD11	11	TxIN12
LP/FHSYNC	LP	27	TxIN24
FP/FVSYNC	FP	28	TxIN25
DE	-	30	TxIN26
FPCLK	FPCLK	25	TxIN23
LVDSCLK	LVDSCLK	31	TxCLKIN

Table 14: PanelLink Transmitter Pin Mapping for TFT Interface

Lynx3DM Pin Name	TFT interface	PanelLink Transmitter Si1100 Pin #	PanelLink Transmitter Pin Name
FPDATA16	R0	63	D0
FPDATA17	R1	62	D1
FPDATA18	R2	61	D2
FPDATA19	R3	60	D3
FPDATA20	R4	59	D4
FPDATA21	R5	58	D5
FPDATA22	R6	57	D6
FPDATA23	R7	56	D7
FPDATA8	G0	55	D8
FPDATA9	G1	54	D9
FPDATA10	G2	52	D10
FPDATA11	G3	51	D11
FPDATA12	G4	50	D12
FPDATA13	G5	49	D13
FPDATA14	G6	48	D14
FPDATA15	G7	47	D15
FPDATA0	B0	46	D16
FPDATA1	B1	44	D17
FPDATA2	B2	43	D18
FPDATA3	B3	42	D19
FPDATA4	B4	41	D20
FPDATA5	B5	40	D21
FPDATA6	B6	38	D22
FPDATA7	B7	37	D23
LP/FHSYNC	FHSYNC	2	HSYNC
FP/FVSYNC	FVSYNC	3	VSYNC
DE	DE	1	DE
FPSCLK	FPSCLK	12	IDCK

Table 15: PanelLink Transmitter Pin Mapping for DSTN Interface

Lynx3DM Pin Name	STN interface	PanelLink Transmitter Si1100 Pin #	PanelLink Transmitter Pin Name
FPDATA12	UD0	50	D12
FPDATA13	UD1	49	D13
FPDATA14	UD2	48	D14
FPDATA15	UD3	47	D15
FPDATA16	UD4	63	D0
FPDATA17	UD5	62	D1
FPDATA18	UD6	61	D2
FPDATA19	UD7	60	D3
FPDATA20	UD8	59	D4
FPDATA21	UD9	58	D5
FPDATA22	UD10	57	D6
FPDATA23	UD11	56	D7
FPDATA0	LD0	46	D16
FPDATA1	LD1	44	D17
FPDATA2	LD2	43	D18
FPDATA3	LD3	42	D19
FPDATA4	LD4	41	D20
FPDATA5	LD5	40	D21
FPDATA6	LD6	38	D22
FPDATA7	LD7	37	D23
FPDATA8	LD8	55	D8
FPDATA9	LD9	54	D9
FPDATA10	LD10	52	D10
FPDATA11	LD11	51	D11
LP/FHSYNC	LP	2	HSYNC
FP/FVSYNC	FP	3	VSYNC
DE	DE	1	DE
LVDSCLK	LVDSCLK	12	IDCK

Chapter 10: Miscellaneous Functions

This chapter describes functions of Lynx3DM such as the Video ROM BIOS interface, VESA DPMS, and I²C / VESA DDC2B.

Video BIOS ROM Interface

The Video BIOS contains code for chip power-on initialization, graphics mode setup, and various read/write routines to the frame buffer. The Video BIOS can be burned into a separate video BIOS EPROM (this is the typical case for add-in cards) or be integrated into the system BIOS ROM (this is the typical case for a motherboard graphics implementation).

To support separate video BIOS ROM access, BIOS address decode must be enabled by setting CSR30 (Expansion ROM Enable Base Address Register) bit 0 = 1. For implementations where video BIOS is integrated into the system BIOS ROM, BIOS address decode access must be disabled by clearing CSR30 bit 0.

Figure 27 shows the external video BIOS ROM configuration interface for Lynx3DM. The \sim ROMEN (ROM Enable) signal from Lynx3DM connects to the OE and CE signals of the BIOS ROM. Since video BIOS ROM address and data are shared with the video memory data (MD) lines, programmers must ensure that the memory bus is inactive when reading from the Video BIOS ROM. For this case, the Video BIOS ROM must be read out and shadowed (typically in system memory at C0000) immediately after reset. Direct physical access to the Video BIOS must then be disabled to prevent interference with ensuing graphics operations.

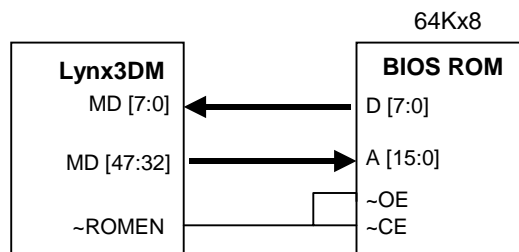

Figure 27: Video BIOS ROM Configuration Interface

VESA DPMS Interface

Lynx3DM supports the VESA Display Power Management Signaling (DPMS) via direct programming PDR22 (LCD Panel Control Select Register) bits 5, 4, or through implementation of the chip's power down states. Table 16 shows the VESA DPMS states and methods for entering each of the DPMS states.

Table 16: DPMS Summary

DPMS State	HSYNC State	VSYNC State	RGB State	Direct Programming Method	Power Down State Method
ON	Pulses	Pulses	Active	PDR22 [5:4] = 00	-
Standby	No pulses	Pulses	Blank	PDR22 [5:4] = 01	Automatic Standby DPMS state when enter Standby mode
Suspend	Pulses	No pulses	Blank	PDR22 [5:4] = 10	CCR69[2]=0 selects Suspend DPMS state when in Sleep mode
OFF	No pulses	No pulses	Blank	PDR22 [5:4] = 11	CCR69[2]=1 selects OFF DPMS state when in Sleep mode

I²C Bus or VESA DDC2B Interface

Lynx3DM provides dual ports for I²C-Bus through USR [3:0] I/O pins for various applications such as VESA's DDC2B monitor interface. It is recommended to use USR1 and USR0 as the primary port for SDA and SCL signals on I²C Bus. USR3 and USR2 are reserved as a secondary port. GPR72 (User Defined Register 1) and GPR73 (User Defined Register 2) are defined to support I²C/DDC2 bus protocol. Lynx3DM, as an I²C master controller only, is designed to initiate a transfer, generate clock signal, and terminate a transfer to a slave I²C component.

Lynx3DM's I²C-Bus interface is designed to interface with NTSC/PAL decoders, EEPROMs, audio decoders, and others. The operation voltage of USR [3:0] I/O pins is controlled by VPVDD, which can be configured as 5V or 3.3V. Each of the USR [3:0] I/O pins has an internal pull-up resistor. To enable the data (SDA) and the clock (SCL) from Lynx3DM's primary port, bit 5 and bit 4 of GPR72 (3C5h index 72h) must be set as "11". To drive a logic "0" to SDA line (USR1) and SCL line (USR0), program GPR72 bit 1 and bit 0 to "0". The SDA and SCL can be read back from bit 3 and bit 2 of GPR72.

Figure 28 shows the basic I²C-Bus protocol of Lynx3DM as a master transmitter.

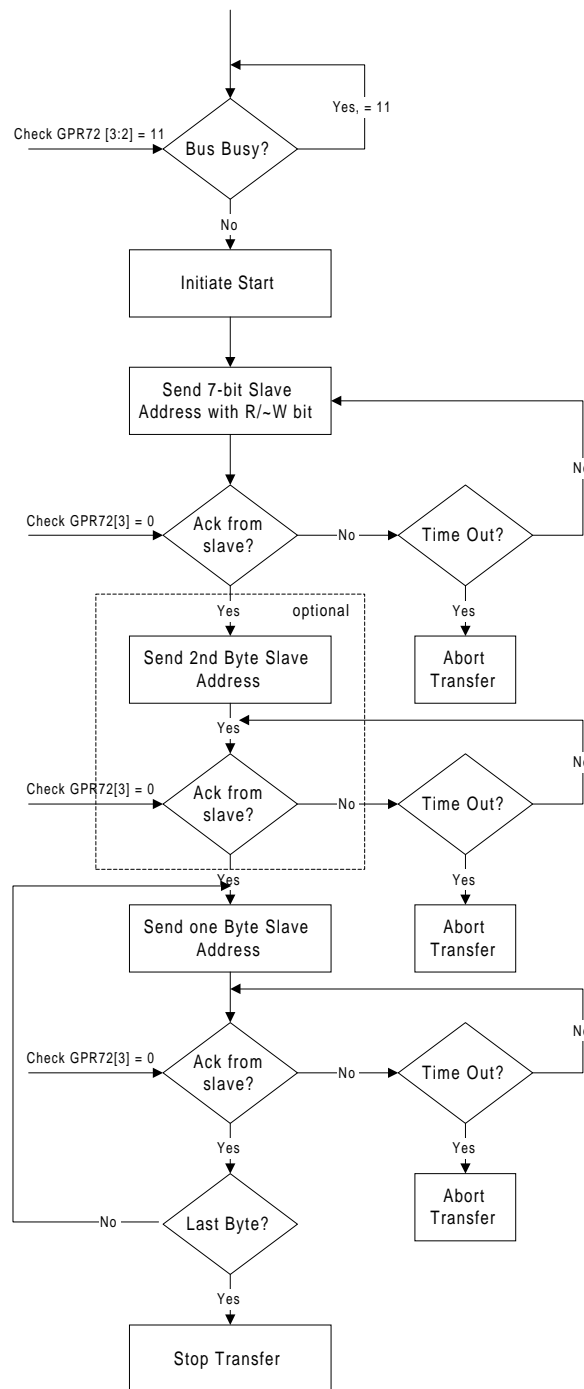

Figure 28: Lynx3DM I²C Bus Protocol Flow Chart

Chapter 11: Clock Synthesizers

Lynx3DM integrates three programmable clock synthesizers for memory clock (MCLK), Video Clock 1 (VCLK), and Video Clock 2 (VCLK2). VCLK1 is utilized for standard CRT only, LCD only, or CRT/LCD display modes for which the refresh rate for both devices is the same. VCLK2 may be utilized when Virtual Refresh mode is implemented - for this case, VCLK1 is utilized for panel timing and to clock the panel display block within Lynx3DM. VCLK2 may be utilized to clock the CRT interface independently for LCD/CRT display modes or to independently clock various functional blocks within the device to save power under LCD only display mode. Please see the Virtual Refresh discussion under the Power Management section for additional details regarding power saving capabilities under Virtual Refresh architecture.

Figure 29 illustrates the control logic for MCLK, VCLK, VCLK2. The figure also shows the clock generator module for WFIFO (WFIFOCLK), RFIFO (RFIFOCLK), RAM (RAMCLK), Video Capture (VCMCLK), Drawing Engine (DPMCLK), and Video Processor (VPCLK). TVCLK is used for an external analog TV encoder (this clock is either derived from 14.318MHz base clock - NTSC, or from separate 17.734480MHz clock source connected to input signal PALCLK - PAL).

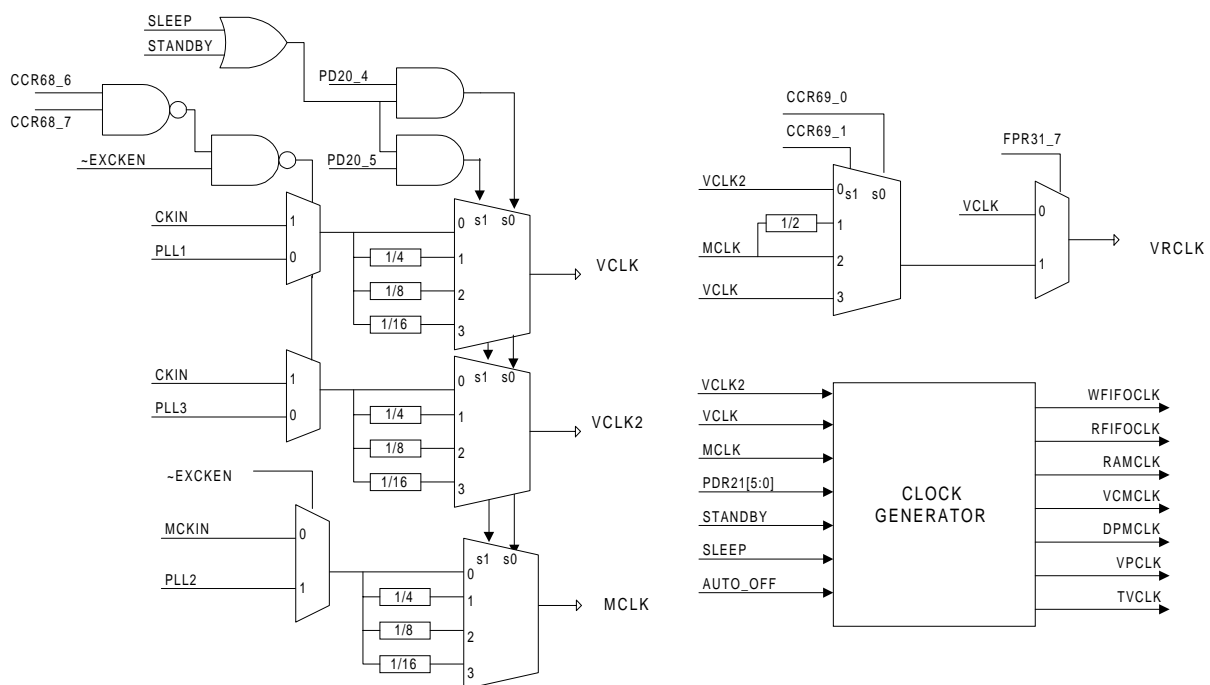

Figure 29: Clocks Generator Block Diagram

The VCLK PLL is programmed using the VCLK Numerator Register (VNR), CCR6C, and VCLK Denominator (VDR) and Post Scalar (PS) register, CCR6D. The VCLK frequency is based on the following equation:

$$VCLK = 14.31818 \text{ MHz} \times \frac{VNR}{VDR} \times \frac{1}{1+PS}$$

The post scalar is used to support VCLK frequencies which need a large VDR number. With PS enabled, the VDR number can be set to ½ of the original VDR number. This helps to reduce jitter and maintain accuracy.

The VCLK2 PLL is programmed using the VCLK2 Numerator Register (VCLK2NR), CCR6E, and VCLK Denominator (VCLK2DR) register CCR6F. The VCLK2 frequency is based on the following equation:

$$VCLK2 = 14.31818 \text{ Mhz} * \frac{VCLK2NR}{VCLK2DR}$$

Table 17: Recommended VNR and VDR Values for Common VCLK Settings

Mode	Ref. Rate	CCR68 [7]	CCR68 [6]	CCR68 [5]	3C2.3	3C2.2	VCLK (MHZ)	VNR	VDR
640x480	60Hz	0	01	0	0	0	25.180	33h	1Dh
720x400									
(text)	70Hz	0	0	0	0	1	28.325	5Bh	97h2
640x480	85Hz	0	0	1	0	0	31.500	2Ch	14h
800x600	56Hz	0	0	1	0	1	35.484	39h	17h
--	--	1	1	x	x	x	14.318	x	x
800x600	72Hz	0	1	x	x	x	49.517	53h	18h
1024x768	75Hz	0	1	x	x	x	78.750	6Eh	14h

Notes:

1. VNR and VDR numbers are hard coded in VGA modes.
2. Post scalar enabled.

The MCLK PLL is programmed using the MCLK Numerator Register (MNR), CCR6A, and MCLK Denominator Register (MDR), CCR6B. MCLK frequency is based on the following equation:

$$MCLK = 14.31818 \text{ MHz} \times \frac{MNR}{MDR}$$

Chapter 12: Multimedia RAMDAC

Lynx3DM contains a multimedia RAMDAC, which supports a maximum frequency of 200MHz (2.5V power supply). The multimedia RAMDAC includes two 256 x 18 color palette RAMs (RAM0 for CRT display, RAM1 for LCD display), RAM Sequencer, Hardware Cursor Registers (foreground and background), Hardware Pop-up Icon Registers (foreground and background), Data Mixer, Power-On Reset, Bias circuit, Monitor Detect circuit, and three 8-bit DACs (R, G and B). Anti-flicker logic for I/O read/writes is also built in the color palette RAM blocks. Figure 30 shows a block diagram of Lynx3DM Multimedia RAMDAC.

Lynx3DM uses an internal band gap voltage reference circuit to supply the reference voltage. This circuit automatically compensates for temperature and power supply variation. The external portion of the circuit consists of a single RSET resistor used to set the full scale voltage of RGB output from DAC.

The RAMDAC supports two types of modes, color palette index mode and direct color mode. In color palette index mode, the 8-bit input data of a given pixel goes to the color palette RAM block through VGA mask register. In direct color mode, pixel data bypasses the color palette RAM.

LCD Backend RAM (RAM1)

Lynx3DM includes a separate 18-bit RAM (6 bits each RGB) module for the LCD backend. The RAM allows support for color palette index modes for the LCD display. This RAM module is written concurrently with RAM0.

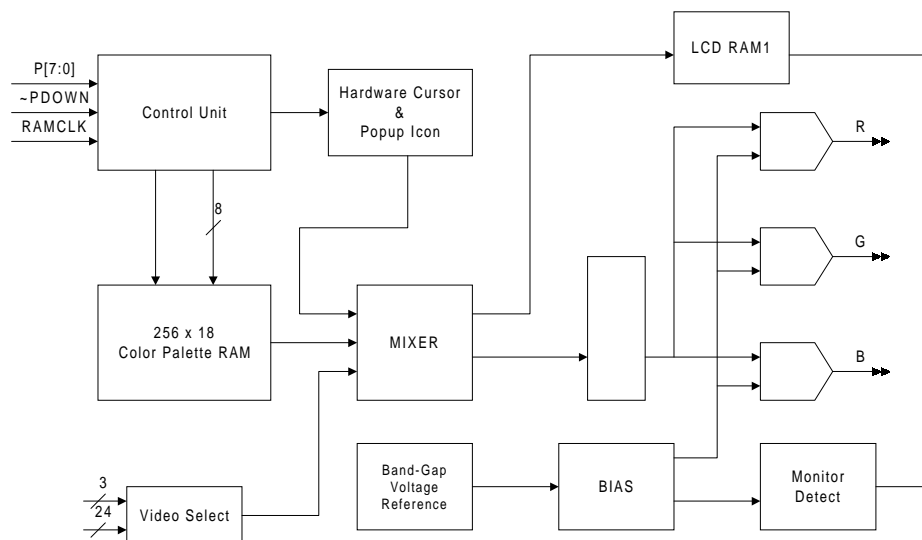

Figure 30: Lynx3DM RAMDAC Block Diagram

Chapter 13: Signature Analyzer

Lynx3DM includes several built-in test features to enhance testability and fault coverage. Lynx3DM's signature analyzer is designed to reduce LSI tester time and manufacturing test time. This signature analyzer resides within the Video Processor block and receives 24-bit RGB data from Multimedia RAMDAC block. It can be used to test CRT graphics modes, TV display modes, and motion video with single frame data. It can also be used to test data combinations such as: graphics, video 1, video 2, HW cursor, and HW pop-up icon at the same time.

The primary variables for a the signature analyzer are the length of the internal shift registers and the number of feedback terms. Lynx3DM implements the CRC-CCITT polynomial ($X^{16} + X^{12} + X^5 + 1$) on a 16-bit signature shift register. VPR64 (Signature Analyzer Control and Status) register is used to define and control the operation of Lynx3DM's signature analyzer. Bit 3 is used as a Enable/Stop bit. Bit 2 is used as a Reset/Normal bit. Bit 1 and 0 are used to select 8-bit Red, Green, or Blue data from the 24-bit outputs of Multimedia RAMDAC. Bit 31 to bit 16 are used to read back the signature from the signature analyzer.

To turn on the signature analyzer, both bit 3 and bit 2 must be set as "11". The signature shift register will be reset to "0" as its initial value. On the rising edge of the 1st vertical sync pulse after VPR64 bit [3:2]=11, the state machine will start collecting signature data. Bit 2 is automatically reset to "0" at the same time. On the rising edge of the next vertical sync pulse, the signature analyzer stops and Bit 3 is automatically reset to "0". The test software can read back the 16-bit signature from Bit [31:16] to compare the golden signature for the test patterns. Figure 31 is a block diagram of the signature analyzer.

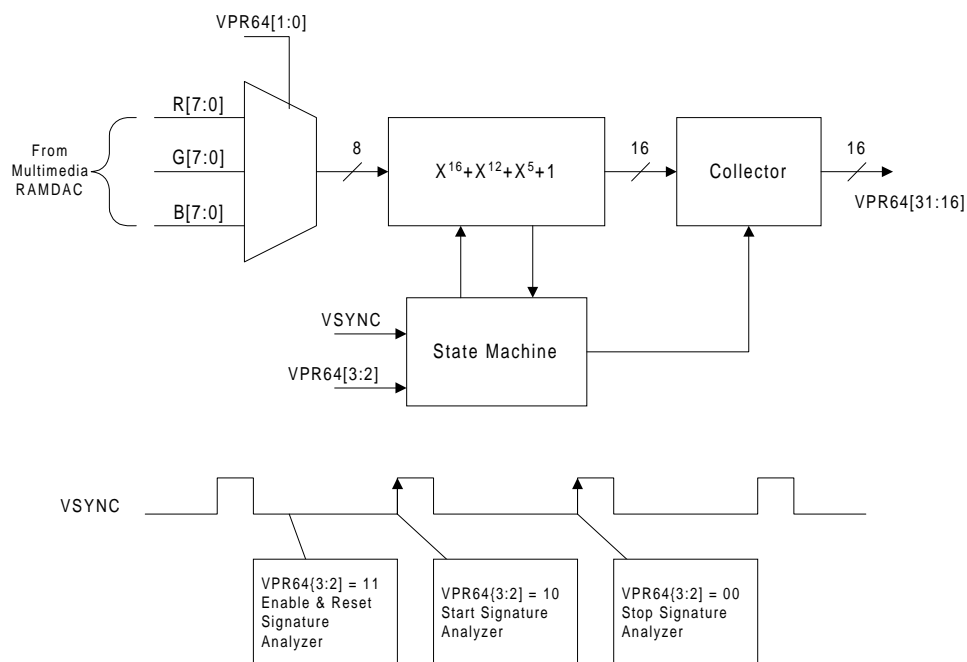

Figure 31: Signature Analyzer Block Diagram

Chapter 14: Power Management

Lynx3DM is designed to support ACPI requirements as defined in the PCI Bus Management Interface Specification 1.0 (PPMI v1.0) and Display device Class Power Management Specification v1.0a. Lynx3DM also supports a variety of adaptive power saving and clock management methods while in full operational mode. Finally, Lynx3DM supports traditional Standby and Suspend mode functionality for operating systems such as Windows 95 which do not have ACPI support built into the OS. A summary of these capabilities follows.

ACPI

Lynx3DM supports D0-D3 modes of operation via software programming of the Power Management Control/Status Register PMSCR[1:0]. As required by the PCI Bus Management Interface Specification, PCI Configuration Space Status Register (offset 06h) bit 4 is set to "1" to indicate new capabilities have been defined for Lynx3DM. At offset 34h, the Cap_Ptr register stores the offset of the new capabilities (this register is hardwired to 40h). The first byte at offset 40h has a value of 01h, which indicates a Power Management capability (supports D1 and D2 states in addition to the required D0 and D3 power states). The second byte has a value of 00h indicating the no additional new capability features (Note: Lynx3DM does not offer support for optional ~PME capabilities as defined in PPMI v1.0).

Please refer to the PCI Bus Power Management Interface Specification 1.0 and Display Device Class Power Management Reference Specification v1.0a for additional details.

Display driver support for ACPI under Windows 98 and future versions of Windows NT will be provided by Silicon Motion in accordance with PC97 and PC98 requirements.

Adaptive Power Management

Lynx3DM provides intelligent power saving control during graphics/video operation. Two key methods through which power savings is achieved are Dynamic control of functional blocks, and dynamic clock control through Silicon Motion's Virtual Refresh architecture.

Dynamic Control of Functional Blocks

All major functional blocks within the device are laid out independently. There is no signal crossover between blocks. Special clock drivers are used to control each of the independent functional blocks. The clock drivers can be turned off by setting Power-Down Registers (PDR20 - PDR22), or by entering the internal auto-standby mode (PDR23 Bit 6). Functional blocks therefore can be turned on/off dynamically in response to how Lynx3DM is being utilized. Since the blocks shut down are unused functional blocks, this power saving feature is transparent to the end user.

Below are some programming recommendations for selected display configurations. These auto power saving features are implemented through video BIOS and system PMI. In addition to these display configuration recommendations, the drawing engine, ZV Port, video processor can be turned off through video driver control.

CRT is the only selected display

- Disable LCD frame buffer write operation (PDR21 bit 5 = 1)
- Disable LCD frame buffer read operation and DSTN dithering engine (PDR21 bit 4 = 1)

Color TFT is the only selected display with normal refresh

- Disable the DAC (PDR21 bit 7= 1)
- Disable LCD frame buffer write operation (PDR21 bit 5= 1)
- Disable LCD frame buffer read operation and DSTN dithering engine (PDR21 bit 4 = 1)

Color DSTN is the only selected display with Virtual Refresh

- Disable the DAC (PDR21 bit 7 = 1)
- Enable auto shut-down of display memory screen refresh cycle and LCD frame buffer write cycle (FPR31 bit 3 = 1)
- Set VCLK clock rate to 10 MHz (reduce clock rate to save power)

TV is the only selected display

- Set VCLK clock rate to 14.1 MHz and set interlaced mode (CRT30 bit 7 = 1)
- Disable LCD frame buffer write operation (PDR21 bit 5= 1)
- Disable LCD frame buffer read operation and DSTN dithering engine (PDR21 bit 4 = 1)

Dynamic Clock Control and Virtual Refresh

Dynamic clock control is made possible through Silicon Motion's Virtual Refresh architecture. Virtual Refresh is an intelligent architecture for dynamic clock control in LCD only mode, as well as independent display refresh control when multiple displays are enabled (e.g. CRT/LCD, TV/LCD). Virtual Refresh utilizes two independent clocks (VCLK, VRCLK): one clock, VRCLK drives the panel interface and maintains proper screen refresh. The second clock, VCLK is now independent of the panel and can be scaled according to user needs (e.g. scaled down for power savings, or scaled up to drive a higher refresh rate on CRT).

Virtual Refresh is enabled by setting FPR31 bit 7 to "1". When the LCD display is the only display viewed by the user, power saving can be achieved via three key functions:

- Dynamically slows down the video clock (VCLK) to 25%~50% of the original clock rate
- Auto shut-down display memory screen refresh
- Auto shut-down the LCD write frame buffer

These functions can be automatically implemented when Lynx3DM detects the user has not performed any activity for a selectable number of screen refresh cycles. Since a significant percentage of the logic is synchronized with VCLK, the average power consumption of the chip will drop dramatically. The LCD screen remains on with proper screen refresh, so the power savings is transparent to the end user.

Note: When multiple displays are used, Virtual Refresh architecture can also be used to simultaneously display CRT/TV and the LCD with different resolutions, and independent refresh rates.

Standard Power Management***Standby Mode***

Lynx3DM supports Standby Mode in two ways: internal auto-standby and system standby from system PMI. The internal auto-standby is enabled and controlled by Activity Detection Register (PDR23). When the internal timer matches the selected condition (PDR23 bit [2:0]), Lynx3DM immediately enters standby mode. Any CPU Memory or I/O access to

Lynx3DM will cause the device to exit standby mode, and reset as an internal counter timer. The system PMI can enable system standby mode by pulling Lynx3DM's "~PDOWN" signal low. (Note: To select standby mode, PDR20 bit 7 must be set to 0 before pulling ~PDOWN low) Lynx3DM will exit standby mode when "~PDOWN" goes high. When the system PMI standby is on, the internal auto-standby is ignored. Programming sequences for internal auto-standby and system standby follow.

Start Internal Auto-standby Mode

- PDR23 bit[7:6] = 11b
- PDR20 bit 7 = 0 to enter standby mode
- The internal timer count matches the setting from PDR23 bit[2:0]

Start System Standby Mode

- PDR20 bit 7 = 0 to enter standby mode
- "~PDOWN" input pin is driven low

Power Saving In Standby Mode

The standby mode is designed to provide an automatic power saving mechanism for the portable PC when the graphics display sub-system is idle for a short period of time. There is no need for BIOS or application software to program Lynx3DM registers. All power saving control are done by hardware. Both internal auto-standby and system PMI standby have the same power saving mechanisms listed below.

- Both memory clock and video clock switch to lower frequencies which are selected by bit [5:4] of PDR20 register
- Lynx3DM will continuously issue DRAM refresh cycles
- The following functional blocks are disabled (PDR21 bit 7, 5, 4, 3, 2, and 1)
 - * DAC
 - * LCD frame buffer write
 - * LCD frame buffer read and DSTN dithering engine
 - * Color Palette RAM
 - * ZV Port
 - * Drawing engine
 - * Video processor
- LCD auto-power off sequence enabled
- VESA DPMS standby mode enabled

Sleep Mode

Sleep mode is the maximizes power-saving mode while maintaining display memory and register integrity. Sleep mode is selected when the whole system will be idle for a long period of time. All selected displays will be shutdown. PLLs can also be shutdown if the external 32 KHz refresh clock is selected (CCR69 bit 3 = 0) or memory self-refresh mode is selected. LCD panel on/off sequence will be done by simply programming the PDR22 register. The programming sequence for Sleep Mode follows.

Setting Before Entering Sleep Mode

- PDR20 bit 7 = 1 to enter sleep mode
- Set PDR20 bit 6 to select memory refresh type
- Set CCR69 bit 3 to select external or internal refresh clock

Enter Sleep Mode (Suspend)

- Power OFF the LCD panel if the LCD display is enabled. There are two ways to power OFF the LCD panel: hardware or software (selected by FPR34 bit 7). For software approach, the system PMI needs to program FPR34 bit 7 = 0 and PDR22 bit [3:0] to control FPEN, FPVDD, VBIAS, VBKLG and panel interface pins. For hardware approach, one needs to program FPR34 bit 7 = 1 and panel ON/OFF timing select via FPR33 [3:2], then Lynx3DM will generate the proper panel sequencing.
- "~PDOWN" input pin is driven low. After ~PDOWN has been asserted for 2 vertical sync cycles, Lynx3DM will automatically shut-down the following blocks:

- * DAC
- * LCD frame buffer write
- * LCD frame buffer read and DSTN dithering engine
- * Color Palette RAM
- * ZV Port
- * 2D/3D drawing engine
- * Video processor
- * Memory screen refresh
- * Start power-down memory refresh cycle

Exit Sleep Mode (Resume)

- Drive "~PDOWN" input high. (200 ms after PLLs are turned on)
- After 200 ms, Power ON the LCD panel by either hardware or software. For software panel sequencing, enable LCD display by programming the PDR22 register. The whole system will be back to original state. For hardware panel sequencing, set FPR34 bit 7 = 1.

Activity Detection

The activity detection function is used to monitor Lynx3DM I/O and memory activity. System designer can select a fixed time period by programming PDR23 bit [2:0]. An internal timer will count the idle period of memory or I/O operation. If the idle period matches the selected value, Lynx3DM will generate a "Low-High" or "High-Low" signal to system through ACTIVITY output pin. Any Memory or I/O operation can reset the ACTIVITY signal and the internal counter.

After receiving the ACTIVITY signal from Lynx3DM, the system power management unit can start Standby mode or Sleep Mode by pulling "~PDOWN" signal low. The activity detection function can also be used to enable internal auto-standby mode by setting PDR23 bit [7:6]. This power saving feature is independent of software and transparent to the end users.

Power-down Sleep Mode States**Table 18: Interface Signals Sleep Mode States**

Signal Name	Sleep Mode
Host Interface	
AD [31:0]	tri-state
C/ ~BE [3:0]	tri-state
PAR	tri-state
~FRAME	tri-state
~TRDY	tri-state

Signal Name	Sleep Mode
~IRDY	tri-state
~STOP	tri-state
~DEVSEL	tri-state
IDSEL	x
CLK	x
~RST	H
~REQ	tri-state
~GNT	x
~INTA	tri-state
Power Down Interface	
~PDOWN	L
~CLKRUN	open-collector
Clock Interface	
REFCLK/PALCLK	x
CKIN	x
LVDSCCLK	tri-state
~EXCKEN	H
Memory Interface	
MA [9:0]	H
MD [63:0]	H or L (note 2)
~WE	H
~RAS	L
~CAS	L
~CS [1:0]	L
~DQM [7:0]	H
DSF	L
BA	H
SDCKEN	L (self-refresh), H (CAS-b-RAS)
SCK	depends on PLL
~ROMEN	H
Flat Panel Interface	
FDATA [23:0]	L
FPSCCLK	L
FPEN	L
FPVDDEN	L
VBIASEN	L
LP/FHSYNC	L

Signal Name	Sleep Mode
FP/FVSYNC	L
CRT Interface	
R, G, B	0 V
CRTVSYNC	L
CRTHSYNC	L
Video Port Interface	
P [15:0]	L
PCLK	H
VREF	H
HREF	H
BLANK/TVCLK	H
General Purpose Registers/I²C	
USR3	H
USR2	H
USR1/SDA	H
USR0/SCL	H
Test Mode Pins	
TEST [1:0]	L

Notes:

1. This entry specifies when PDR20 bit 6 = 1 (self-refresh). When PDR20 bit 6 = 0 (CAS before RAS), both ~RAS and ~CAS control are based on 32K Hz refresh clock
2. MD lines have internal pull-up, therefore, without external pulldown resistors, MD lines will be at HIGH. With external pulldown resistors, MD lines will be at LOW.

Chapter 15: Motion Compensation Specification

Overview

The Motion Compensation block (MC) executes a series of instructions in a pipelined fashion. There is actually only one type of instruction with several flags that control the instruction execution. The MC instruction is similar to a CPU arithmetic instruction with three sources (imm - IMMEDIATE operand, mrd - Memory ReaD and acc - ACCumulator) and one destination (mwr - Memory WRite). The main difference between standard CPU instructions and those used by the MC is that the MC instruction works on rectangular blocks of data instead of 8, 16, 32, or 64-bit integers.

The rectangular blocks of data (rectangles) used by the MC are 2-dimensional arrays containing 8-bit values. For the current implementation, the horizontal and vertical sizes (hsize and vsize) are limited to the following ranges: hsize = 8 or 16; vsize = 4 or 8. The MC requires one 128x16 SRAM for temporary storage of the input and output array values. It acts as a CPU accumulator.

The throughput of the MC pipeline is two pixels per cycle. Under worst case assumptions a MPEG-2 MP@ML picture will thus require 22 Mcycles/second.

Data Flow and External System Responsibilities

All instructions for motion compensation are generated by a software front-end and fed to the graphics controller via a standard software API. The instructions specify two different types of operations: (1) Memory accesses used for reading prediction data and writing reconstructed pels, and (2) Data processing operations used to combine predictions with the error terms generated by the IDCT operation.

The MC core handles all data processing operations required for motion compensation. The graphics memory controller handles the memory access operations. The memory controller must read the instructions generated by software, fetch prediction data, feed the data to the MC block and write the final reconstructed pels into the proper location.

MC Top Level Architecture

The top level architecture of the MC core is shown in Figure 32. It consists of a simplified quadrilinear filter (mc_qlf - this is the data path), a 128x16 dual port SRAM, and a controller (mc_ctl). The MC has four data busses: command (cmd), immediate operand (imm), memory read (mrd) and memory write (mwr).

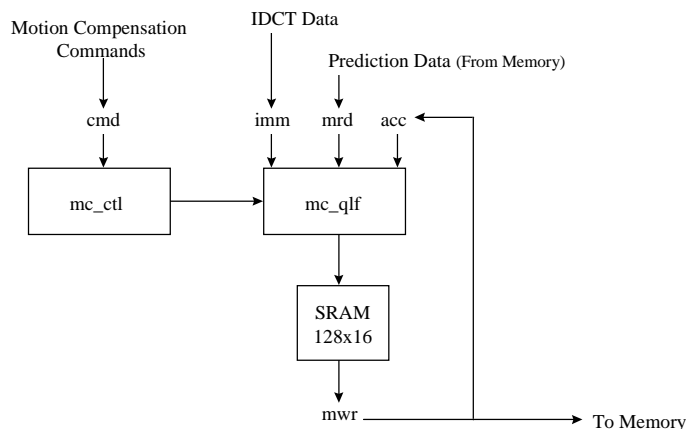

Figure 32: MC Top Level Architecture

In the current architecture all input and output busses are kept separate to offer the maximum processing throughput. Except for the command bus, all busses can operate continuously at one 16-bit or 18-bit value per cycle (two pixels/cycle). All busses use a rdy-ack protocol and can be stalled on any cycle.

For MPEG the IDCT output is fed through the imm bus and the prediction through the mrd bus. For bidirectionally interpolated macroblocks, first the forward prediction is read, half-pel interpolated, and stored in the 128x16 memory (block ACCumulator). Next, the backward prediction is read, half-pel interpolated, and added to both the acc (forward prediction) and imm (immediate or IDCT) data.

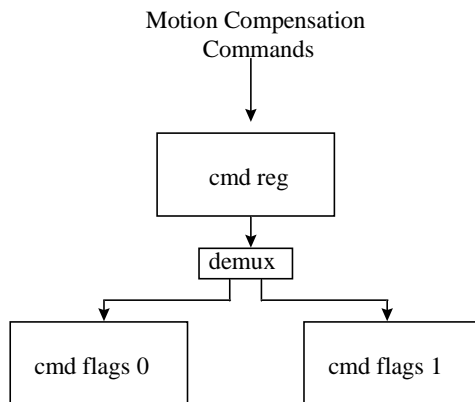

Figure 33: Control Block Diagram

Words from the cmd bus are loaded directly into the 16-bit cmd register as the command pipeline advances. The flags0 and flags1 registers each hold exactly one instruction each and together form a 2 instruction FIFO. One instruction is encoded as 2 or more 16-bit words, which means that it will take 2 or more pipeline advances before a flags register has accepted an entire instruction. Having 2 instructions queued at a time allows the MC to prepare an idle QLF pipeline with data ahead of time - before the current instruction has completed.

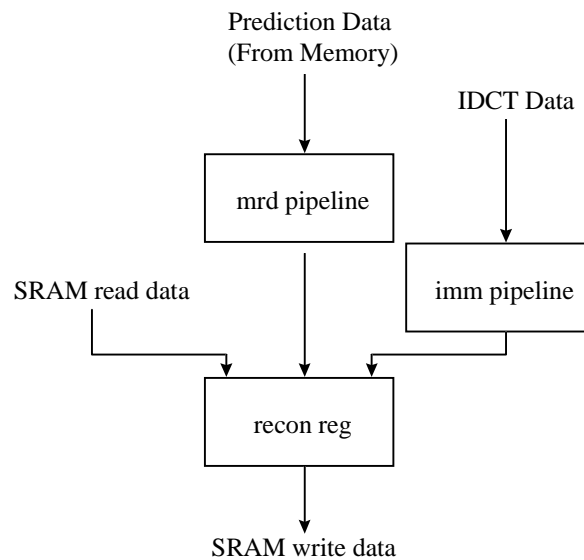

Figure 34: QLF Block Diagram

The Quadrilinear Filter consists of three pipelines, namely the acc, mrd, imm pipelines. The acc pipeline is not shown in block diagram because it consists of two stages external to the MC. The first stage is the synchronous SRAM read port while the second stage is a register that accepts SRAM read data. The width of this register matches the width of the reconstruction memory write back (mwr) data and is application dependent.

The mrd pipeline accepts prediction data from memory in a 16-bit wide format (2-pels). Pel alignment, horizontal half pel interpolation, and vertical half pel interpolation are handled in the pipeline.

The imm pipeline accepts IDCT data in a 18-bit (9-bit pel) or 16-bit (8-bit pel) format. The data is reformatted based on the flags in the current instruction.

Data from the three pipelines is combined and held in the reconstruction register. The data is added together, then saturated to values between 0 and 255. From this register the data is written to the local SRAM 16-bits (2 pels) at a time.

MC Instruction Format and Operation

Figure 36 shows the MC instruction format. The flags and parameters in the instructions are summarized in Table 19. All MC commands have the most significant bit (MSB) of word A set=1. Commands that have the MSB cleared=0, are intended for the memory controller or other control logic external to the MC. Currently, the only command with MSB=0 is used to indicate the end of stream:

	f	e	d	c	b	a	9	8	7	6	5	4	3	2	1	0
A	0	0	0	0	0	0	0	0	0	0	0	0	0	0	0	0
B	0	0	10000					0	0	0	00000					0

Figure 35: End Stream Instruction

This End Stream command can occur anywhere in a command stream and should trigger an end to the command stream transfer. After this instruction is encountered by hardware, communication would then take place between hardware and the driver to determine what step to take next. This command is intended for logic external to the MC but should also be passed on to the MC. The MC will see it as a Flush command and is required in order for the results from the last valid command to be written to memory.

The following table defines the format for MC instructions. Notice that the MSB of word A is set=1, indicating that this is an MC instruction.

	f	e	d	c	b	a	9	8	7	6	5	4	3	2	1	0
A	1	-	ISL	IM8	MRD	IMM	ACC	MWR	THB	LHB	IH0	IH1	TVB	LVB	IV0	IV1
B	-	-	hsize [4:0]					HHP	-	-	vsize [4:0]					VHP
C	mrd_slot[1:0]		mrd_plane[1:0]		mrd_hadder [11:0]											
D	-			RVS	mrd_hadder [11:0]											
E	mrd_slot[1:0]		mrd_plane[1:0]		mrd_hadder [11:0]											
F	-			WVS	mrd_hadder [11:0]											

Figure 36: MC Instruction Format

Table 19: Instruction Flags and Parameters

Flag	Parameter	Meaning
ISL		Immediate Shift Left vs. sign extend left
IM8		IMmediate data 8-bits per pixel
MRD		Memory Read
IMM		IMMediate
ACC		ACCumulate
MWR		Memory WRite
THB		Two Horizontal Blocks
LHB		interLeaved Horizontal Blocks
IH0		Immediate operand for Horizontal block 0
IH1		Immediate operand for Horizontal block 1
TVB		Two Vertical Blocks
LVB		interLeaved Vertical Blocks
IV0		Immediate operand for Vertical block 0
IV1		Immediate operand for Vertical block 1
	hsize [4:0]	Horizontal SIZE

Flag	Parameter	Meaning
HHP		Horizontal Half Pel interpolation
	vsize [4:0]	Vertical SIZE
VHP		Vertical Half Pel interpolation
	mrd_slot [1:0]	Memory ReaD SLOT
	mrd_plane [1:0]	Memory ReaD PLANE
	mrd_haddr [11:0]	Memory ReaD Horizontal ADDRess
	mrd_vaddr [11:0]	Memory ReaD Vertical ADDRess
RVS	mrd_vstep	Memory ReaD Vertical STEP
	mwr_slot [1:0]	Memory WRite SLOT
	mwr_plane [1:0]	Memory WRite PLANE
	mwr_haddr [11:0]	Memory WRite Horizontal ADDRess
	mwr_vaddr [11:0]	Memory WRite Vertical ADDRess
RVS	mwr_vstep	Memory ReaD Vertical STEP

Each MC instruction consists of two, four or six 16-bit words. The first instruction, instruction A in Figure 36, contains the instruction flags. The second instruction contains the rectangle size. Depending on the flags in the first instruction, the remaining four instructions may or may not be present.

In instruction A, the most important flags are MRD, IMM, ACC, and MWR. These flags indicate what source operands are used and if the result should be stored to memory or to the accumulator (the 128x16 memory). All or none of these four flags can be set. If none of the source flags are set, the MC generates a rectangle of zeros.

If the MRD (Memory ReaD) flag is set, instructions C and D must be present. These instructions specify the address from which prediction data should be fetched. The memory slot (prediction slot) from which to read the data is given by the mrd_slot [1:0]. A slot contains one frame of video which can be broken down into two or three color planes: (Y, Cb, Cr) or (Y, Cb/Cr interleaved). Each color plane can be broken down into two fields. The top field is located in the even lines while the bottom field is located in the odd lines of the frame. The X-Y offset in the slot (frame) from which to fetch the data is given by the mrd_haddr [11:0] and mrd_vaddr [11:0]. The vertical step, mrd_vstep, indicates whether every line or every other line should be read from the slot. For frame prediction every line is read (mrd_vstep = 0) and for field prediction every other line is read (mrd_vstep = 1). The first line of a rectangle of prediction data is indicated by mrd_vaddr [11:0]. In field prediction (mrd_vstep = 1), which field the data must come from depends on the location the first line of the prediction rectangle. If that line is in the top field, then the data comes from the top field. Otherwise it comes from the bottom field.

The parameter mrd_plane (Memory ReaD PLANE) indicates which video plane is being processed (0=Y, 1=Cb, 2=Cr, 3=CbCr). For MPEG decompression the memory read plane, mrd_plane [1:0] and memorywrite plane, mwr_plane [1:0], are always equal. (Note: they are provided as different values to offer increased flexibility for other applications (read from one plane and write to a different plane)).

If the MWR is set, instruction E and F must be present. These instructions specify the address to which the final computed pels should be written. Similar to the data read instructions, the write slot is indicated by mwr_slot [1:0]. The X-Y offset is indicated by mwr_haddr [11:0] and mdr_vaddr [11:0]. The mwr_vstep bit specifies whether or not to skip a line between successive rows written in the same way that the mrd_vstep does for the prediction data. In MPEG-2 decode, mwr_vstep setting reflects the motion type for the macroblock being processed.

In instruction B, if HHP is set, Horizontal Half Pel interpolation is performed and the mrd horizontal size shall be hsize pixels plus one. If VHP is set, Vertical Half Pel interpolation is performed and mrd vertical size shall be vsize rows plus one.

If the ACC flag is set, the MC adds the content of the ACCumulator (the 128x16 memory to be memory read data (if present)).

If the IMM flag is set, the MC adds the immediate data, supplied on the imm bus, to the interpolated data, $(mrd = acc)/2$. The immediate data is the error term calculated by the IDCT. All the other nine flags have a meaning only if IMM is set.

IM8 indicates if the immediate data is only 8 bits wide. If IM8=0 the MC will accept IDCT data in a 9-bit per pixel format. MPEG-2 defines a range for IDCT data from -256 to =255 which is covered by a 9-bit two's complement number. A setting of IM8=1 indicates that the data is in an 8-bit per pixel format which approximates the full range. The ISL flag is used in conjunction with IM8 and differentiates between two 8-bit modes. ISL is ignored when IM8=0. 8-bit approximations allow data to be packed more efficiently into standard word widths. At issue is the sign bit. Intra-coded macroblocks never use the sign bit since values are restricted to the range of 0 to +255, while predicted to bidirectional IDCT values take the range of -256 to +255. For this reason, commands are separated into two different categories: intra-coded and non intra-coded.

If IM8=1 and ISL=0, the MC first determines the type of command currently being executed, then generates the sign bit based on the category. Intra-coded values are zero extended, while non intra-coded values are sign extended to the full 9 bits. Software that decodes the IDCT data must remove the sign bit in the intra-coded case while saturating the lower 7 bits and removing the 8th bit in the non intra-coded case. Non-intra coded data retains its sign bit since the saturation process results in a 8-bit twos complement number whose most significant bit represents its sign.

The IM8=1/ISL=0 setting will put an upper limit on the amount of correction that can be made to prediction data though. After the correction IDCT error terms can be no greater than =127 and no less than -128. As mentioned before, MPEG-2 specifies the range to be between +255 and -256. Under normal conditions values rarely exceed the smaller range since motion is relatively slow from picture to picture. When they do, it will be almost impossible for an observer to notice since the corrupted pels will be located in an area where a great deal of motion is occurring. In some rare cases though this range clipping can cause visible artifacts. They can be corrected though, with a second IMM data "pass". Instructions with settings of MRD=1, ACC=1 and IMM=1 calculate results as follows:

$$acc = (mrd+acc) / 2 = imm$$

Instructions with settings of MRD=0, ACC=1 and IMM=1 calculate results differently:

$$acc = acc + imm$$

This allows for a correction of IMM data terms that were saturated to the range of [-128, +127]. The first IMM pass would correct to this smaller range while the second pass would allow for a correction to a range of [-256 +254]. To reach a correction of +255, a third pass can be generated but would not be required very often.

If IM8=1 and ISL=1, the MC shifts the 8-bit IMM data left one bit before performing calculations with it. Intra coded and non-intra coded commands both treat the IMM data this way. Software must drop the least significant bit of the original 9-bit terms to convert to the format of the data required in this mode. This is the fastest way to generate 8-bit IMM data but will result in lower quality video. Images that contain large areas of a single color will suffer contour lines.

The remaining eight flags are needed to accommodate all possible combinations of coded_block_pattern and dct_type. The immediate data is present only if indicated by these flags. The term "reconstruction plane" in the following paragraphs refers to data that is written to the MC block's local SRAM as a result of a given command. Each reconstructed pel has a horizontal and vertical component that make up its position in the plane.

IH0 and IH1 indicate that the coded_block_pattern flag is set (IDCT data is present) for the one or two horizontal blocks that are processed. IH0 is used for the left most pels while IH1 is used for the right most. Pel locations in the reconstruction plane are assigned to one of the coded block pattern (cbp) bits, namely IH0, IH1, or IV1. IDCT data is only used in the reconstruction calculation for a given location when its cbp bit is 1. Otherwise, the IDCT data is either masked out or missing from the immediate data stream.

IV0 and IV1 are the cbp bits used when two vertical blocks are present. In MPEG terms, IV0 can be thought of as indicating that block Y2 is coded. IV1 can be thought of as indicating whether Y3 is coded. IDCT data is re-ordered to be combined with prediction data (MRD bus). For this reason, the cbp bits may not apply evenly to adjacent blocks as they do in the MPEG bitstream. Their assignment to locations in the reconstruction plane reflect the change in the order of the IDCT data.

TVB indicates that Two Vertical Block as are processed at the same time. If TVB is high, IH0 and IH1 are used for the top half of the rows while IV0 and IV1 are used for the bottom half. In the top half, whether IH0 and IH1 is used will be dependent on the horizontal reconstruction pel position, THB and LHB. The same is true of IV0 and IV1 in the bottom half. TVB is not an indicator of the number of vertical rows for a command. The vsize [3:0] bits indicate this. Although if TVB is high, vsize [3:0] bits indicate this. Although if TVB is high, vsize [3:0] is used to determine the vertical half-way point for a command.

LVB indicates that two Blocks are Vertically interLeaved. This is needed when frame prediction and field DCT type data are used in a frame picture. When LVB is high, the even rows in the reconstruction plane are assigned to IH0 and IH1 while the odd rows are assigned to IV0 and IV1.

For MPEG related applications, TVB and LVB will never both be set high. A command generator that sets them both will not cause a failure in the MC though. The result will be a union of the two modes. The top half of the rows will be interleaved while the bottom half will not. All of the bottom rows will be assigned to the IV0 and IV1 cbp bits.

THB indicates that Two Horizontal Blocks are processed at the same time. When THB is high, either IH0 and IV0 will be assigned to the left most half of a reconstruction row, while IH1 or IV1 will be used for the right most half. In the left half, whether IH0 and IV0 is used will be dependent on the row number, TVB and LVB. The same is true of IH1 and IV1 in the right half. THB is not an indicator of the number of horizontal pels in a row. The hsize [4:0] bits indicate this. Although if THB is high, hsize [4:0] is used to determine the half-way point in a row.

LHB indicates that two Blocks are Horizontally interLeaved. This is needed when chroma (Cb and Cr) is stored in a single plane to save memory bandwidth. When LHB is high, the upper 9 or 8 bits of the imm [17:0] bus are interpreted as a Cb IDCT pel and IH0 and IV0 is used as a mask while the lower 9 or 8 bits are interpreted as Cr with IH1 or IV1 as a mask. When a coded block pattern bit is 0 the corresponding immediate data is masked to 0 before being used in reconstruction calculations. Unlike non-interleaved cases, data for the pels masked to 0 must be present in the immediate data stream even though their values are thrown out. When LHB is set high, the THB bit is ignored. Setting both bits high has the same effect as setting LHB high and THB low.

Chapter 16: 3D Engine

The Lynx3DM engine consists of a triangle setup engine, triangle fill engine, texture engine and pixel engine.

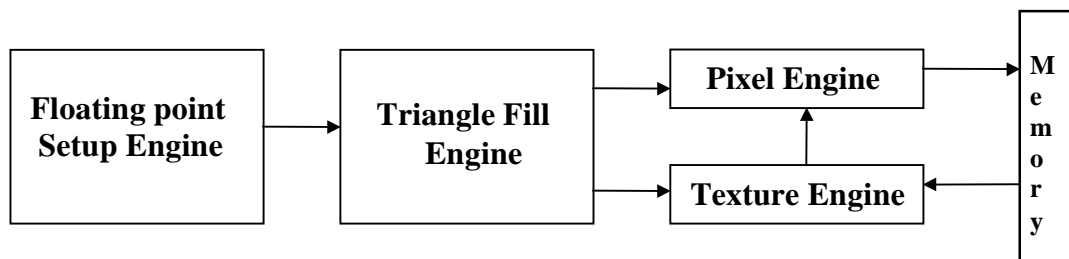

Figure 37: 3D Engine Block Diagram

IEEE 754 Floating Point Setup Engine

Lynx3DM incorporates a full triangle setup engine in hardware, relieving the host processor of these duties, as well as the need to transfer the setup data across the PCI Bus (43 double words per triangle). This frees up the host processor to perform tasks such as game logic and setting up data for the next frame. The result is higher triangle rates, and lower CPU utilization.

The setup engine computes triangle slope parameters (x, y, z, color (rgba) and texture parameters (s,t,w)). The triangle engine uses this information to walk along the edge of the triangle and generate span lines to be shaded or textured. Slope computation require divide operations in floating point to achieve maximum precision. The setup engine also performs subpixel correction (fractional adjustment calculations of the slope parameters to the pixel center) to eliminate polygon and texture misalignment.

The key components of the setup engine are 2 floating points units which work in parallel to perform triangle slope computations. In addition there is a hardware vertex sorting function to sort triangle vertices based on Y coordinates, as well as vertex transfer DMA to free the host CPU from transferring thousands of triangle vertices from host memory to the setup engine.

The vertex buffers within the setup engine (V0,V1,V2) consist of x,y,z,r,g,b,a,s,t,w (10) triangle parameters whose formats (floating point) are matched to Direct3D or OpenGL requirements. There is fixed to floating point format hardware conversion capability for color, as the data is specified as fixed point format in D3D.

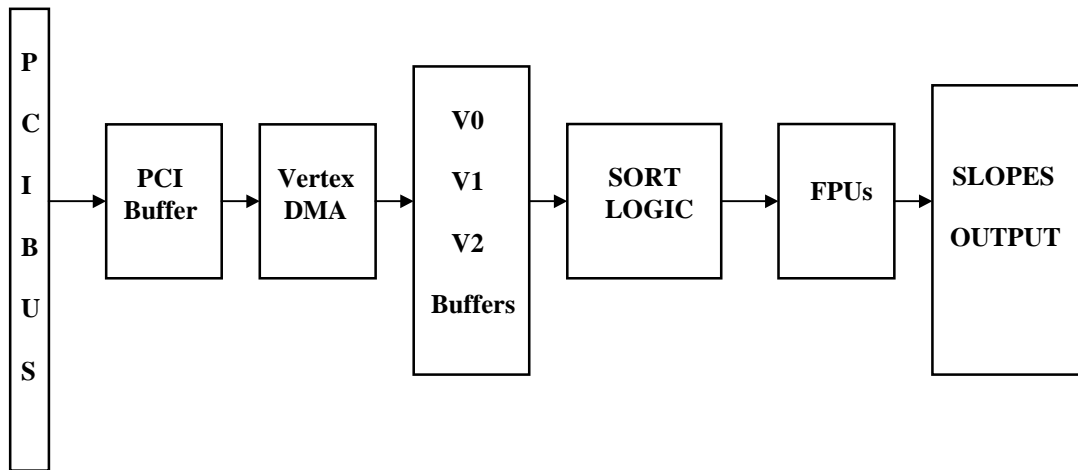

Figure 38: Setup Engine Block Diagram

Triangle Engine

The slope data from the triangle setup engine is passed to the edge walker within the triangle setup engine. The edge walker interpolates along the major edge of a triangle, generating horizontal Z, Gouraud and texture span lines simultaneously and calculating their starting values (RGBA and STW). The span engine interpolates the lines into pixels (Gouraud shading) and texels (via texture engine) to be combined (modulated, added, blended) in the pixel pipeline stages within the Pixel Engine.

Significant parallelism is achieved by running the span engine, texture engine and Z engine in parallel.

All pixel rendering is calculated internally as 32-bit RGBA data. Triangle engine supports 2 separate interpolators for diffuse and specular color.

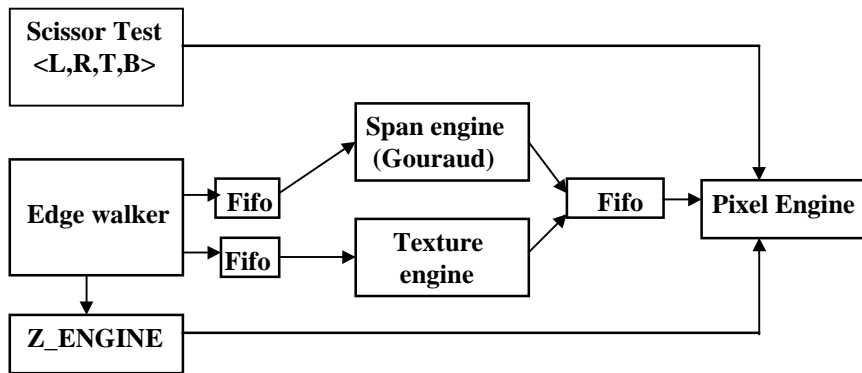

Figure 39: Triangle engine block diagram

Z Engine

The Z buffer (16bpp) process is performed in parallel with other triangle engine operations. The Z_engine whose output determines if pixel is to be drawn or not.

Z relational operation:

- 000 = Z disabled
- 001 = pass if Zi .GT. Zzb
- 010 = pass if Zi .EQ. Zzb
- 011 = pass if Zi .GE. Zzb
- 100 = pass if Zi .LT. Zzb
- 101 = pass if Zi .NE. Zzb
- 110 = pass if Zi .LE. Zzb
- 111 = Z always passes

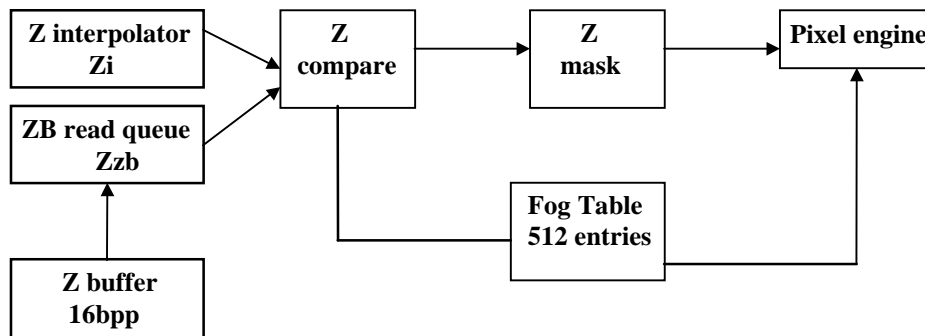

Figure 40: Z Engine Block Diagram

Texture Engine

Lynx3DM supports perspective correct texture mapping (divide per pixel), various texture filtering such as point sampling, bilinear, and trilinear mip-mapping (per pixel LOD) to eliminate texture aliasing.

Point sampling and bilinear texture filtering are done in a single pass. Trilinear mip-mapping and texture compositing (multiple texture map) are done in 2 passes.

Texture engine supports the following source texture formats: RGBA_8888, RGBA_4444, RGB_1555, RGB_565 and 8-bit color index with separate look up table.

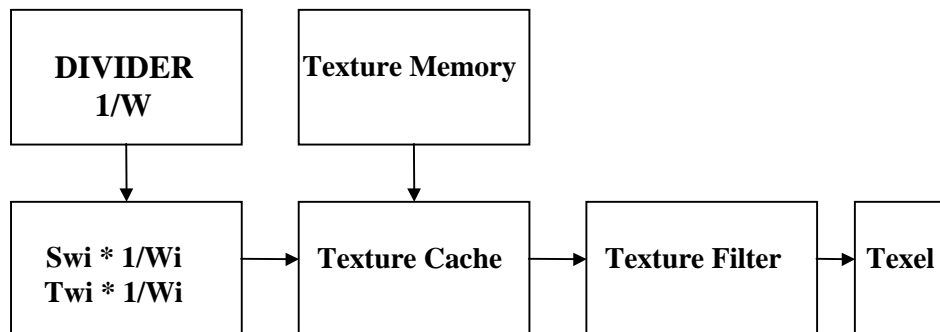

Figure 41: Texture Engine Block Diagram

Pixel Engine

The Pixel Engine consists of a series of pipeline stages (operations) to combine texture color and diffuse color (highlighting), add specular color, and create transparency and atmospheric fog/haze effects. In addition, the Pixel Engine performs edge anti alias to eliminate jaggedness.

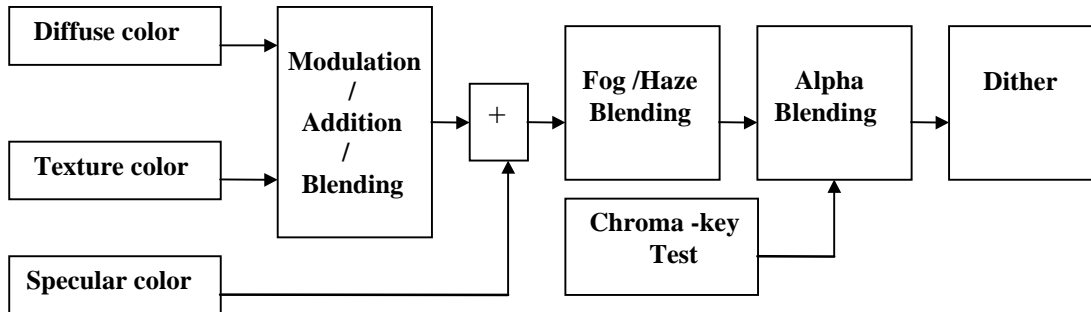

Figure 42: Pixel pipeline block diagram

Modulation/Addition Unit

Combine pixel (diffuse color) from gouraud span engine with texel from texture engine. Includes modulation (multiplication), addition and blending operations.

Fog Blending Unit

Fog blend factor per pixel is computed based on Z distance. Lynx3DM supports both local fog (fog blend factor is derived from iterated fog blend factor at vertex level) and global fog (fog blend factor is from fog table indexed by z at that pixel). Global fog gives more realistic effect as local fog tends to give fog band effect due to linearly interpolated fog factor at the vertex level.

Chroma-Key Test Unit

Chroma-key is used in conjunction with transparency (alpha blend). If enabled, the texel from texture engine is compared to the chroma-key value and if within range then the alpha blending factor is set to 0, which essentially means disable pixel write.

Alpha Blending Unit

The Alpha Blending unit blends incoming source pixels with destination pixels. One of the most common function of alpha blend is to create a translucent object. Lynx3DM supports most of the blend functions specified by microsoft D3D API and OpenGL.

Dithering Unit

The Dithering unit is used to improve 16-bit RGB (5:6:5) color representation on the display without actually storing the pixel data as 24 Bit data in the frame buffer. Dithering matrixes are used to represent the 16-bit RGB data as 24-bit RGB data on screen.

Chapter 17: TV Encoder

The TV Encoder is an NTSC/PAL Composite Video/S-video Encoder. It receives RGB inputs and converts to digital video signals based on CCIR 624 format.

The input video signal of the TV Encoder is RGB 8-bit each. The sampling rate is corresponding to CCIR 601, Square pixel and 4Fsc (NTSC only).

The output video signals of the TV Encoder are Composite video signal and S-video signals of 10-bit each. These output signals are over-sampled by a double frequency clock called CLKX2. This feature helps to simplify external analog filtering.

The TV Encoder video timing is controlled by vertical sync and the horizontal sync input signals. The blank signal input is optional. If the blank signal input signal is pulled up, internal blanking control will be performed.

Macrovision 7.01 and closed captioning functions are included.

Key Feature Summary

- NTSC/PAL interlace mode digital video encoder
- Composite Video and S-Video digital output
- CCIR 601, Square pixel and 4Fsc (NTSC only) resolution RGB input
- Slave timing operation
- Interlace mode operation
- 2x over-sampling data output to simplify external analog filtering
- Selectable pedestal level OIRE/7.5IRE for NTSC
- Macrovision function (version 7.01)
- Closed captioning function

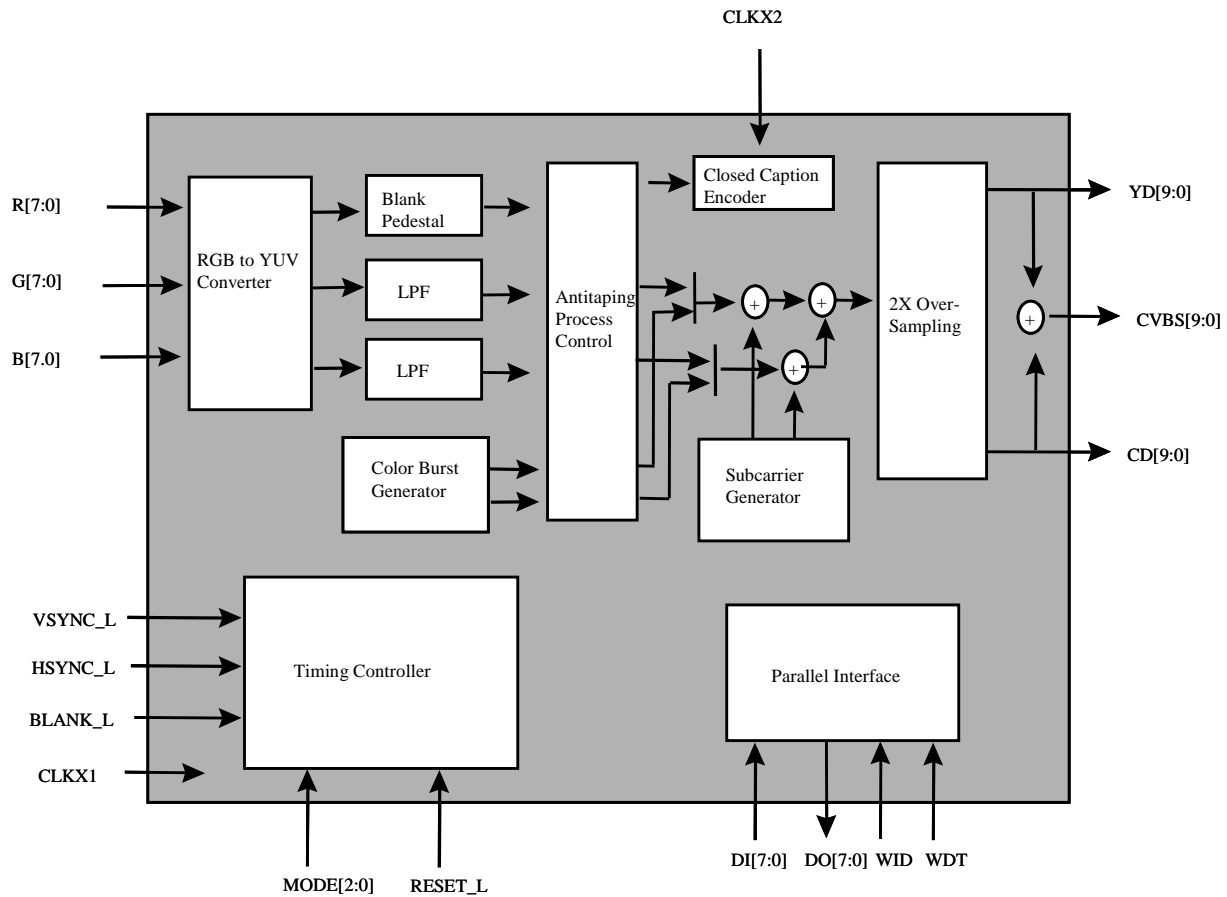

Figure 43: TV Encoder Block Diagram

Table 20: TV Encoder Block Interface Description

Excure-TV Encoder for SMI pin list

Pin name	Width	I/O	Description
R	8	I	4:4:4 sampled Red data This data should be synchronized to the CLKX1.
G	8	I	4:4:4 sampled Green data This data should be synchronized to the CLKX1.
B	8	I	4:4:4 sampled Blue data This data should be synchronized to the CLKX1.
VSYNC_L	8	I	Vertical sync input, active low This goes low during the vertical sync intervals.
HSYNC_L	1	I	Horizontal sync input, active low This goes low during the horizontal sync intervals.
BLANK_L	1	I	Composite blanking input, active low. This goes low during the composite blanking intervals. If this signal is low, the RGB input data will be masked.
CLKX1	1	I	Pixel rate clock input This clock should be free-running, and will be synchronized to the CLKX2.

Pin name	Width	I/O	Description
CLKX2	1	I	2X Pixel rate clock input This clock should be free-running.
MODE	3	1	Mode select When MR[7] is set to 1, the mode is controlled by these input pins, otherwise the mode register (MR) setting will be taken. 000: NTSC CCIR 100: PAL CCIR 001: NTSC Square Pixel 101: PAL Square pixel 010: NTSC 4Fsc
RESET_I	1	I	Reset input, active low
MV_EN	1	I	Macrovision function Enable
DI	8	I	Parallel I/F data input
DO	8	O	Parallel I/F data output
WID	1	I	Parallel I/F index strobe
WDT	1	I	Parallel I/F data strobe
CVBS	10	O	S-video Luminance data output
YD	10	O	Composite video data output
CD	10	O	S-video Chrominance data output

Function Descriptions

Video data input and sampling rate

The video input data is RGB. Each R, G, or B data is an 8-bit value. The range for the data is 0 to 255 respectively. The data is latched at positive edge of the CLKX1.

The TV Encoder supports the following sampling rates:

Table 21: TV Encoder Sampling Rates

Video Mode		Frequency	Total pixel/line	Total lines/frame
NTSC	CCIR 601	13.5 MHz	858	525
	Square pixel	12.27 MHz	780	525
	4Fsc	14.32 MHz	910	525
PAL	CCIR 601	13.5 MHz	864	625
	Square pixel	14.75 MHz	944	625

Macrovision Antitaping process

The TV Encoder supports the Macrovision Antitaping process function (U7.01). Macrovision involves 3 functions which are the colorstripe process, Pseudo Sync/AGC pulses with sync pulse amplitude reduction and EOF back porch pulses.

If the same line is assigned for closed captioning and the Macrovision process, all Macrovision functions at the line are disabled for the closed captioning function.

The color stripe process function is applied to the composite video output and the Chrominance signal output. This is activated by MCR0[3] and controlled by MCR1 to MCR7 and MCR16 to MCR21. This function controls the color burst length and polarity. When this process is invoked during the burst blanking lines, no color burst signal is put. When the color burst length is assigned beyond the active video time, the color burst completes at the end of the blanking time. Active video data then starts. The blanking time is controlled by the BLANK-L input pin and internal blanking.

The Pseudo Sync/AGC pulse function is applied to the composite video output and the S-video Luminance output. The Pseudo Sync pulse is applied to the Luminance signal. The AGC pulse is a super-white positive going pulse. Both of these pulses are output after color burst signal. The Sync Pulse amplitude reduction changes the synchronizing level. This function is activated by MCR0[5] and MCR0[1:0], and controlled by MCR0[2], MCR8 to MCR14.

The EOF back porch pulse function generates a high level signal immediately after the trailing edge of the H-sync pulse. The value is 100IRE for NTSC mode and 700mV for PAL mode. This function is activated by MCR0[4], and controlled by MCR[15].

Closed Captioning

The closed captioning function is applied to the Luminance data, and is shown at the composite video output and the S-video Luminance output as follows. The level and timing corresponds to the EIA standard EIA-608.

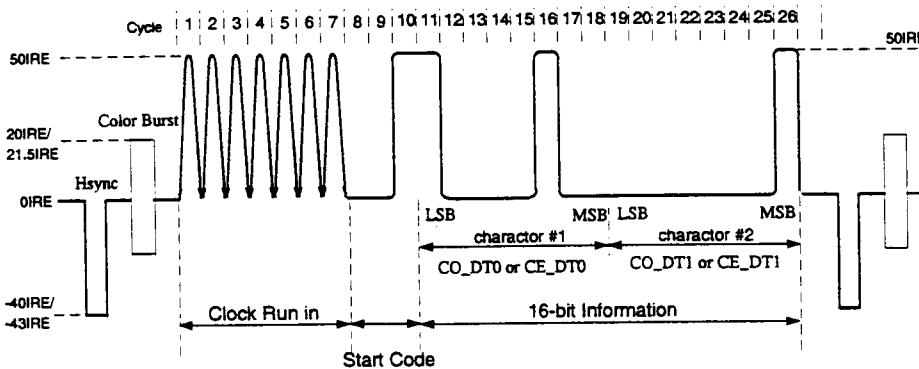

This function is controlled by the closed captioning registers. The closed captioned line is controlled as follows.

Table 22: Closed Captioning Lines

Video Mode	Odd field	Even field
NTSC	CCL + 4	CCL + 263 + 4
PAL	CCL + 1	CCL + 313 + 1

When the closed captioning function is enabled by the CCEN register, the captioning data will be placed on the assigned line. When there is new data, the TV Encoder outputs the new data. When there is no new data, a null code (80h) will be output.

The odd field and even field are controlled separately. When one of 2 odd (even) data registers is written, the TV Encoder recognizes new data for odd (even) field. The status bit OST(EST) is set to 1. For normal usage, the new data is written when the status bit is 1.

Table 23: Closed Captioning Odd Field Output Data

Enable	Status	1st Output Data	2nd Output Data
CCE[0] = 0	-	no data	no data
CCE[0] = 1	OST = 0	CO_DT0	CO_DT1
CCE[0] = 1	OST = 1	80 (hex)	80 (hex)

Table 24: Closed Captioning Even Field Output Data

Enable	Status	1st Output Data	2nd Output Data
CCE[0] = 0	-	no data	no data
CCE[0] = 1	EST = 0	CO_DT0	CE_DT1
CCE[0] = 1	EST = 1	80 (hex)	80 (hex)

Video data output and Over-sampling

The TV Encoder outputs composite video, Luminance and Chrominance signals. These outputs have 10-bit each, and are 2X over-sampled by the double frequency clock designated CLKX2. This over-sampling simplifies external analog filtering. The output level and timing depend on the mode selected.

Synchronization

This TV Encoder operates in a slave mode. This means that the vertical sync and the horizontal sync are required for operation. The blanking signal is optional. The TV Encoder will calculate the composite blanking time using the sync information. If the blank signal BLANK-L is pulled up, input data at the blanking time will be masked by the internal blanking signal. When the blanking signal is controlled, it's possible to shorten the active time for the input data. The TV Encoder will mask the input data when the BLANK-L is low. The TV Encoder automatically detects the Odd/Even field by sync information.

Sub-carrier Generation

The sub-carrier is internally generated using CLKX1. Depending on the sampling rate, the TV Encoder will automatically calculate exact frequency. The sub-carrier phase is reset under the following conditions:

- RESET-L is low.
- The first field changes to field 1 after RESET- goes high.
- The first field changes to field 1 after the TV Encoder detects the mode change.
- When genlock control is on. For this case, the sub-carrier phase will be reset on every 4 fields for NTSC mode and 8 fields for PAL mode.

Parallel bus I/F

For internal register access, the parallel bus I/F is used. When the write index signal designated WID is high, the register address is latched. When the write data signal designated WDT is high, the data will be written to the latched address.

Chapter 18: Register Overview & Usage

There are generally 3 types of registers:

PCI Configuration Registers

The PCI Configuration registers are listed in Chapter 19: PCI Configuration Space Registers and accessed via the standard PCI read/write protocols specified in the PCI specification.

Memory Mapped I/O Registers

All the I/O mapped registers within Lynx3DM have been designed to be memory mapped as well. They are listed in Chapter 20: Standard VGA Registers and Chapter 21: Extended SMI Registers. “I/O” or “Memory” Mapping is selected through PCI configuration registers CSR04 bit 0 and bit 1.

- Access via “I/O” space is done by first writing the index value into the I/O register 3C4. Thereafter, the indexed register can be accessed via I/O read/write to I/O address 3C5

Example: Register with Index 0/H

I/O write 0/H to 3C4

I/O read/write to/from 3C5

- The procedure to access these registers via “Memory” Mapped space is similar to “I/O” space in that the index register is moved to memory address C0xxx and the access register is moved to C0xxx (where “xxx” represents the VGA control numbers.

Example: Register with Index 0/H

Memory write 0/H to C03C4

Memory read/write to/from C03C5

Memory Mapped Registers

All the advanced functions of Lynx3DM are controlled through Memory Mapped registers. Such as the 2D and 3D Motion Comp Registers in Chapter 22: 2D & Video Registers, Chapter 23: Motion Comp Video Registers, Chapter 24: PCI Bus Master Control Registers, Chapter 25: 3D Registers, and Chapter 26: TV Encoder Registers. The following diagram illustrates the Memory Mapped register address assignment.

I/O Mapped Register Mapped Summary

IBM VGA Sequencer Registers	Index 0 - 4
System Control Registers	Index 10- 1F
Power Down Control Registers	Index 20 - 24
Flat Panel Control Registers	Index 3X - 5X
Memory Control Registers	Index 60 - 63
Clock or Power Down Control Registers in PPR Block	Index 64 - 6F
USR0-3 Ports Control Registers General Purpose Control Registers	Index 70 - 73
Scratch Registers	Index 74 - 75
Memory Control Registers	Index 76
Monitor Detect and CRT/TV DAC Test Registers	Index 7A-7D
HWC & Pop Icon Registers	Index 80-8D
Pop Icon Registers	Index 90 - 93

Figure 44: I/O Port 3C4

IBM VGA CRTC Registers	Index 0 - 26
Extended CRTC Control Registers	Index 30 - 3C
Scratch Registers	Index 3D - 3F
CRT Shadow Registers	Index 40 - 4D
TV Encoder Control Registers	Index 6X - 8X
Screen Centering & Expansion Control	Index 90 - 9F; Index A0 - AD
I/O Map to Video Processor Control Registers	Index C0 - EF
Capture Port Control Register	Index FF

Figure 45: I/O Port 3?4

	2D3D Reg Port	2K	0000_0000 - 0000_07ff
	Video Reg Port	2K	0000_0800 - 0000_0fff
	Vidcap Reg Port	2K	0000_1000 - 0000_17ff
	MC ICMD Reg Port	2K	0000_1800 - 0000_1fff
	MD IDCT Reg Port	2K	0000_2000 - 0000_27ff
	Mas Mif Reg Port	2K	0000_2800 - 0000_2fff
	2D3D Master Reg Port	2K	0000_3000 - 0000_37ff
	MC Core Reg Port	2K	0000_3800 - 0000_3fff
	MC ICMD Data Port	2K	0000_4000 - 0000_47ff
	MC IDCT Data Port	2K	0000_4800 - 0000_4fff
	Mas Mif Data Port	2K	0000_5000 - 0000_57ff
	// not used //	2K	0000_5800 - 0000_5fff
	2D3D Data Port	8K	0000_6000 - 0000_7fff
	// not used //	712K	0000_8000 - 000b_ffff
	Memory Map IO Space	256K	000c_0000 - 000f_ffff
	Additional DE Data Port	1MB	0010_0000 - 001f_ffff
FB Space	30MB Frame Buffer	30MB	0020_0000 - 01ff_ffff

Figure 46: Memory Mapped Address Diagram

Chapter 19: PCI Configuration Space Registers

Table 25: PCI Configuration Registers Quick Reference

Summary of Registers	Page
CSR00: Vendor ID	19 - 2
CSR02: Device ID	19 - 2
CSR04: Command	19 - 2
CSR06: Status	19 - 3
CSR08: Revision ID and Class Code	19 - 4
CSR0D: Latency Timer	19 - 4
CSR10: Memory Base Address Register	19 - 5
CSR2C: PCI Configuration Space Subsystem Vendor ID	19 - 5
CSR2E: PCI Configuration Space Subsystem ID	19 - 5
CSR30: Expansion ROM Base Address	19 - 6
CSR34: Power Down Capability Pointer	19 - 6
CSR3C: Interrupt Line	19 - 6
CSR3D: Interrupt Pin	19 - 7
CSR40: Power Down Capability Register	19 - 7
CSR44: Power Down Capability Data	19 - 7
CSR50: AGP Capability Pointer	19 - 8
CSR51: Next Capability Pointer	19 - 8
CSR52: Major Minor Revision	19 - 8
CSR53: Reserved	19 - 9
CSR54: AGP Status Pointer	19 - 9
CSR58: AGP Command Register	19 - 9
<i>Extended SMI Registers</i>	
LOCK: Extended Register Write Protect Control	19 - 10

PCI Configuration Space Registers

The PCI specification defines the configuration space for auto-configuration (plug-and-play), device and memory relocation.

CSR00: Vendor ID

Read Only Address: 00h
Power-on Default: 126Fh

This register specifies the vendor ID

31	30	29	28	27	26	25	24	23	22	21	20	19	18	17	16
RESERVED															
15	14	13	12	11	10	9	8	7	6	5	4	3	2	1	0
VENDOR ID															

Bit 31:16 Reserved

Bit 15:0 Vendor ID
This register is hardwired to 126Fh to identify as Silicon Motion[®], Inc.

CSR02: Device ID

Read Only Address: 02h
Power-on Default: 0720h

This register specifies the device ID.

31	30	29	28	27	26	25	24	23	22	21	20	19	18	17	16
DEVICE ID															
15	14	13	12	11	10	9	8	7	6	5	4	3	2	1	0
RESERVED															

Bit 31:16 Device ID
This register is hardwired to 0720h to identify the device as Lynx3DM.

Bit 15:0 Reserved

CSR04: Command

Read/Write Address: 04h Note: Reserved bits are read only
Power-on Default: 00h

This register controls which types of PCI command cycles are supported by Lynx3DM.

31	30	29	28	27	26	25	24	23	22	21	20	19	18	17	16
RESERVED															
15	14	13	12	11	10	9	8	7	6	5	4	3	2	1	0
RESERVED										PSE	MWR	R	PCI	MS	IO

Bit 31:6 Reserved

Bit 5 Palette Snooping Enable (PSE)
0 = Disable
1 = Enable

Bit 4 Memory Write Invalidate Enable for PCI master (MWR)
0 = Disable
1 = Enable

Bit 3 Reserved (R)

Bit 2 PCI Master Enable (PCI)
0 = Disable
1 = Enable

Bit 1 Memory Space Access Enable (MS) (Note: This bit needs to be set to "1" in order to enable BIOS addressing decoding)
0 = Disable
1 = Enable

Bit 0 I/O Space Access Enable (IO)
0 = Disable
1 = Enable

CSR06: Status

Read Only Address: 06h
Power-on Default: 20h

This register controls device select timing status, detect parity status, and detects target abort status for Lynx3DM. In order to clear any bit of this register, you must write a "1" to that particular bit.

31	30	29	28	27	26	25	24	23	22	21	20	19	18	17	16
RESERVED															
15	14	13	12	11	10	9	8	7	6	5	4	3	2	1	0
DPE	RESERVED	DTA	R	TS	RESERVED										

Bit 31:16 Reserved

Bit 15 Detect Parity Error (DPE)

- Bit 14:13** Reserved (R)
- Bit 12** Detect Target Abort for Master Mode (DTA)
- Bit 11** Reserved (R)
- Bit 10:9** ~DEVSEL Timing Select (TS)
01 = medium speed (hardwired)
- Bit 8:0** Reserved

CSR08: Revision ID and Class Code

Read Only Address: 08h
Power-on Default: 030000A0h

This register specifies the silicon revision ID and the Class Code that the silicon supports.

31	30	29	28	27	26	25	24	23	22	21	20	19	18	17	16
BASE CLASS CODE								SUBCLASS CODE							
15	14	13	12	11	10	9	8	7	6	5	4	3	2	1	0
REG LEVEL PROGRAMMING INTERFACE								REVISION ID							

- Bit 31:24** Base Class Code
03h = for Video Controller
- Bit 23:16** Subclass Code
00h = VGA
- Bit 15:8** Register Level Programming Interface
00h = hardwired setting
- Bit 7:0** Revision ID
For example, A0h = revision A; B0h = revision B

CSR0D: Latency Timer

Read Only Address: 0Dh
Power-on Default: 00h

This register specifies the latency timer that Lynx3DM supports for burst master mode.

7	6	5	4	3	2	1	0
LATENCY TIMER							

- Bit 7:0** Latency Timer for burst capable master

CSR10: Memory Base Address Register

Read/Write Address: 10h (Note: Reserved bits are read only)

Power-on Default: 00h

This register specifies the PCI configuration space for address relocation

31	30	29	28	27	26	25	24	23	22	21	20	19	18	17	16
LINEAR ADDRESSING MEMORY BASE						RESERVED									
15	14	13	12	11	10	9	8	7	6	5	4	3	2	1	0
RESERVED															MSI

Bit 31:26 Linear Addressing Memory Base Address. Memory segment allocated within 64 MB boundary**Bit 25:1** Reserved**Bit 0** Memory Space Indicator (MSI) (Read only)
0 = memory base**CSR2C: PCI Configuration Space Subsystem Vendor ID**

Read Only Address: 2Ch

Power-on Default: 00h

This register specifies the Subsystem device ID.

15	14	13	12	11	10	9	8	7	6	5	4	3	2	1	0
SUBSYSTEM DEVICE ID															

Bit 15:0 Subsystem ID. This System ID is written by system BIOS during POST**CSR2E: PCI Configuration Space Subsystem ID**

Read Only Address: 2Eh

Power-on Default: 0720h

This register specifies the Subsystem Vendor ID.

15	14	13	12	11	10	9	8	7	6	5	4	3	2	1	0
SUBSYSTEM VENDOR ID															

Bit 15:0 Subsystem Vendor ID

CSR30: Expansion ROM Base Address

Read/Write Address: 30h

Power-on Default: 00h

This register specifies the expansion ROM base address. Note: Reserved bits are read only.

31	30	29	28	27	26	25	24	23	22	21	20	19	18	17	16
ROM BASE ADDRESS															
15	14	13	12	11	10	9	8	7	6	5	4	3	2	1	0
RESERVED															BIOS

Bit 31:16 ROM Base Address. Memory segment allocated for BIOS ROM in 64KB boundary [15:0]**Bit 15:1** Reserved

Bit 0 BIOS Address Decode Enable. This bit is valid only if memory space access is enabled. (CSR04 bit 1 = 1)
 0 = Disable
 1 = Enable

CSR34: Power Down Capability Pointer

Read Only Address: 34h

Power-on Default: 40h

This register contains the address where PCI power down management registers are located

7	6	5	4	3	2	1	0
CAPABILITY POINTER/PCI POWER DOWN MGMT							

Bit 7:0 Capability pointer contains the address where PCI Power Down Management Register are located.**CSR3C: Interrupt Line**

Read/Write Address: 3Ch

Power-on Default: 00h

This register specifies the PCI Interrupt Line.

7	6	5	4	3	2	1	0
INTERRUPT LINE							

Bit 7:0 Interrupt Line

CSR3D: Interrupt Pin

Read Only Address: 3Dh

Power-on Default: 01h

This register specifies the PCI Interrupt Pin.

7	6	5	4	3	2	1	0
RESERVED							IP

Bit 7:1 Reserved**Bit 0** Interrupt Pin (IP) (~INTA)**CSR40: Power Down Capability Register**

Read Only Address: 40h

Power-on Default: 0601_5001h

This register contains the address where PCI power down management Capabilities.

31	30	29	28	27	26	25	24	23	22	21	20	19	18	17	16
PCI POWER DOWN MANAGEMENT CAPABILITY (0601h)															
15	14	13	12	11	10	9	8	7	6	5	4	3	2	1	0
NEXT CAPABILITY POINTER LINK LIST								PCI POWER DOWN MGMT CAPABILITY (01h)							

Bit 31:16 PCI Power Down Management Capability = 0601h
Offset 2**Bit 15:8** Next Capability Pointer Link List = 50h
Offset 1**Bit 7:0** PCI Power Down Management Capability ID= 01h
Offset 0**CSR44: Power Down Capability Data**

Read/Write Address: 44h

Power-on Default: 00h

This register contains the address where PCI power down management Control, Status and Data

31	30	29	28	27	26	25	24	23	22	21	20	19	18	17	16
DATA								RESERVED							
15	14	13	12	11	10	9	8	7	6	5	4	3	2	1	0
PCI POWER DOWN MGMT CONTROL/STATUS															

Bit 31:24 Data
Read Only. Offset 7

Bit 23:16 Reserved =00
Offset 6

Bit 15:0 PCI Power Down Management Control/Status
Offset 4

CSR50: AGP Capability Pointer

Read/Write Address: 50h
Power-on Default: 02h

7	6	5	4	3	2	1	0
AGP CAPABILITY POINTER							

Bit 7:0 AGP Capability Pointer

CSR51: Next Capability Pointer

Read/Write Address: 51h
Power-on Default: 00h

7	6	5	4	3	2	1	0
NEXT CAPABILITY POINTER							

Bit 7:0 Next Capability Pointer

CSR52: Major Minor Revision

Read/Write Address: 52h
Power-on Default: 00h

7	6	5	4	3	2	1	0
MAJOR MINOR REVISION							

Bit 7:0 Major Minor Revision

CSR53: Reserved

Read/Write Address: 53h

Power-on Default: 00h

7	6	5	4	3	2	1	0
RESERVED							

Bit 7:0 Reserved**CSR54: AGP Status Pointer**

Read Only Address: 54h

Power-on Default: 00h

31	30	29	28	27	26	25	24	23	22	21	20	19	18	17	16
REQUEST DEPTH								RESERVED							
15	14	13	12	11	10	9	8	7	6	5	4	3	2	1	0
RESERVED						SBA	RESERVED			4GS	FWE	R	DATA RATE		

Bit 31:24 Request Depth**Bit 23:10** Reserved**Bit 9** Side Bus Addressing Enabled (SBA)**Bit 8:6** Reserved**Bit 5** 4 GB Support**Bit 4** Fast Write Enabled**Bit 3** Reserved (R)**Bit 2:0** Data Rate**CSR58: AGP Command Register**

Read/Write Address: 58h

Power-on Default: 00h

31	30	29	28	27	26	25	24	23	22	21	20	19	18	17	16	
REQUEST DEPTH								RESERVED								
15	14	13	12	11	10	9	8	7	6	5	4	3	2	1	0	
RESERVED						SBA	AGP	RESERVED			4GS	FWE	R	DATA RATE		

Bit 31:24	Request Depth
Bit 23:10	Reserved
Bit 9	Side Bus Addressing Enabled (SBA)
Bit 8	AGP Enabled
Bit 7:6	Reserved
Bit 5	4 GB Support
Bit 4	Fast Write Enabled
Bit 3	Reserved (R)
Bit 2:0	Data Rate

Extended SMI Registers**LOCK: Extended Register Write Protect Control**

Read/Write Address: 3C3h

Power-on Default: 00h

This register specifies write protect controls for the SMI extended registers. SMI extended registers are write-protected. In order to write to the SMI extended registers, one must write Bit [7:5] = 010b.

7	6	5	4	3	2	1	0
WPE			RESERVED				

Bit 7:5 Write Protect Enable (WPE)
 101 = All SMI Extended registers are Write-Protected
 010 = Enable writes to SMI Extended registers
 Others = Maintain previous state

Bit 4:0 Reserved

Chapter 20: Standard VGA Registers

Table 26: Standard VGA Registers Quick Reference

Summary of Registers	Page
<i>General Registers</i>	
MISC: Miscellaneous Output Register	20 - 4
ISR0: Input Status Register 0	20 - 4
ISR1: Input Status Register 1	20 - 5
FCR: Feature Control Register	20 - 5
<i>Sequencer Register</i>	
SEQX: Sequencer Index Register	20 - 6
SEQ00: Reset Register	20 - 6
SEQ01: Clocking Mode Register	20 - 7
SEQ02: Enable Write Plane Register	20 - 7
SEQ03: Character Map Select Register	20 - 8
SEQ04: Memory Mode Register	20 - 8
<i>CRTC Controller Registers</i>	
CRTX: CRTC Controller Index Register	20 - 9
CRT00: Horizontal Total Register	20 - 9
CRT01: Horizontal Display End Register	20 - 10
CRT02: Horizontal Blank Start Register	20 - 10
CRT03: Horizontal Blank End Register	20 - 10
CRT04: Horizontal Sync Pulse Start Register	20 - 11
CRT05: End Horizontal Sync Pulse Register	20 - 11
CRT06: Vertical Total Register	20 - 12
CRT07: Overflow Vertical Register	20 - 12
CRT08: Preset Row Scan Register	20 - 13
CRT09: Maximum Scan Line Register	20 - 13
CRT0A: Cursor Start Scan Line Register	20 - 14
CRT0B: Cursor End Scan Line Register	20 - 14
CRT0C: Display Start Address High Register	20 - 15
CRT0D: Display Start Address Low Register	20 - 15

Summary of Registers	Page
CRT0E: Cursor Location High Register	20 - 15
CRT0F: Cursor Location Low Register	20 - 16
CRT10: Vertical Sync Pulse Start Register	20 - 16
CRT11: Vertical Sync Pulse End Register	20 - 16
CRT12: Vertical Display End Register	20 - 17
CRT13: Offset Register	20 - 17
CRT14: Underline Location Register	20 - 18
CRT15: Vertical Blank Start Register	20 - 18
CRT16: Vertical Blank End Register	20 - 18
CRT17: CRT Mode Control Register	20 - 19
CRT18: Line Compare Register	20 - 20
CRT22: Graphics Controller Data Latches Readback Register	20 - 20
CRT24: Attribute Controller Toggle Readback Register	20 - 20
CRT26: Attribute Controller Index Readback Register	20 - 21
<i>Graphics Controller Registers</i>	
GRXX: Graphics Controller Index Register	20 - 21
GRX00: Set/Reset Register	20 - 22
GRX01: Enable Set/Reset Register	20 - 22
GRX02: Color Compare Register	20 - 22
GRX03: Data Rotate/ROP Register	20 - 23
GRX04: Read Plane Select Register	20 - 23
GRX05: Graphics Mode Register	20 - 24
GRX06: Graphics Miscellaneous Register	20 - 25
GRX07: Color Don't Care Plane Register	20 - 25
GRX08: Bit Mask Register	20 - 26
<i>Attribute Controller Registers</i>	
ATRX: Attribute Controller Index Register	20 - 26
ATR00-0F: Palette Register	20 - 27
ATR10: Attribute Mode Control Register	20 - 27
ATR11: Overscan Color Register	20 - 28
ATR12: Color Plane Enable Register	20 - 28
ATR13: Horizontal Pixel Panning Register	20 - 29
ATR14: Color Select Register	20 - 30
<i>RAMDAC Registers</i>	
3C6: DAC Mask Register	20 - 30
3C7W: DAC Address Read Register	20 - 31
3C7R: DAC Status Register	20 - 31

Summary of Registers	Page
3C8: DAC Address Write Register	20 - 31
3C9: DAC Data Register	20 - 32

Standard VGA Registers

In the following registers description, a '?' in an address stands for a hexadecimal value of either 'B' or 'D'. If Bit 0 of the Miscellaneous Output Register is set to 1, the address is based at 3Dxh for color emulation. If Bit 0 of the Miscellaneous Output Register is set to 0, the address is based at 3Bxh for monochrome emulation.

General Registers

MISC: Miscellaneous Output Register

Write Only Address: 3C2h

Read Only Address: 3CCh

Power-on Default: 00h

7	6	5	4	3	2	1	0
VSP	HSP	OEM	R	VIDEO CLOCK		EVR	IO

- Bit 7** Vertical Sync Polarity Select (VSP)
0 = positive vertical sync polarity
1 = negative vertical sync polarity
- Bit 6** Horizontal Sync Polarity Select (HSP)
0 = positive horizontal sync polarity
1 = negative horizontal sync polarity
- Bit 5** Odd/Even Memory Page Select (OEM)
0 = Select lower 64K page of memory
1 = Select upper 64K page of memory
- Bit 4** Reserved (R)
- Bit 3:2** Video Clock Select
00 = Select 25.175MHz for 640 dots/line mode
01 = Select 28.322MHz for 720 dots/line mode
10 = Reserved (enable external clock source)
11 = Reserved (enable external clock source)
- Bit 1** Enable Video RAM Access from CPU (EVR)
0 = Disable Video RAM access from CPU
1 = Enable Video RAM access from CPU
- Bit 0** I/O Address Select (IO)
0 = Select monochrome mode. Address based at 3Bxh.
1 = Select for color mode. Address based at 3Dxh

ISR0: Input Status Register 0

Read Only Address: 3C2h

Power-on Default: Undefined

7	6	5	4	3	2	1	0
CRT	RESERVED		MDS	RESERVED			

Bit 7 CRT Vertical Retrace Interrupt (CRT)
0 = Vertical Retrace Interrupt is cleared
1 = Vertical Retrace Interrupt is pending.

Bit 6:5 Reserved

Bit 4 Monitor Detect Status (MDS)
0 = Monochrome display is detected
1 = Color display is detected

Bit 3:0 Reserved

ISR1: Input Status Register 1

Read Only Address: 3?Ah
Power-on Default: Undefined

7	6	5	4	3	2	1	0
RESERVED		COLOR PLANE	VRS	R	DISPLAY ENABLE		

Bit 7:6 Reserved

Bit 5:4 Color Plane Diagnostics
These bits return two of the 8 video outputs VID0-VID7, as selected by Color Plane Enable Register [5:4]

Bit 3 Vertical Retrace Status (VRS)
0 = In display mode
1 = In vertical retrace mode

Bit 2:1 Reserved (R)

Bit 0 Display Enable
0 = In display mode
1 = Not in display mode. (it is either in horizontal or vertical retrace mode)

FCR: Feature Control Register

Write Only Address: 3?Ah
Read Only Address: 3CAh
Power-on Default: 00h

7	6	5	4	3	2	1	0
RESERVED				VSC	RESERVED		

Bit 7:4 Reserved

Bit 3 Vertical Sync Control
 0 = VSYNC output is enabled
 1 = VSYNC output is logical 'OR' of VSYNC and Vertical Display Enable

Bit 2:0 Reserved

Sequencer Register

SEQX: Sequencer Index Register

Read/ Write Address: 3C4h
 Power-on Default: Undefined

7	6	5	4	3	2	1	0
RESERVED				SEQUENCER ADDRESS/INDEX			

Bit 7:4 Reserved

Bit 3:0 Sequencer Address/Index
 The Sequencer address register is written with the index value of the sequencer register to be accessed.

SEQ00: Reset Register

Read/ Write Address: 3C5h, Index: 00h
 Power-on Default: 00h

7	6	5	4	3	2	1	0
RESERVED						SR	AR

Bit 7:2 Reserved

Bit 1 Synchronous Reset (SR)
 0 = Sequencer is cleared and halted synchronously
 1 = Normal operating mode

Bit 0 Asynchronous Reset (AR)
 0 = Sequencer is cleared and halted asynchronously
 1 = Normal operating mode

SEQ01: Clocking Mode Register

Read/ Write Address: 3C5h, Index: 01h

Power-on Default: 00h

7	6	5	4	3	2	1	0
RESERVED		SO	VS	DCS	SL	R	DC

Bit 7:6 Reserved

Bit 5 Screen Off (SO)
 0 = Normal operating mode
 1 = Screen is turned off but SYNC signals remain active

Bit 4 Video Serial Shift Select (VS)
 0 = Load video serializer every or every other character or clock, depending on Bit2 of this register.
 1 = Load video serializer every 4th character clock

Bit 3 Dot Clock Select (DCS)
 0 = Normal dot clock select by VCLK input frequency
 1 = Dot clock is divided by 2 (320/360 pixel mode)

Bit 2 Shift Load (SL)
 0 = Load video serializer every character or clock
 1 = Load video serializer every other character or clock

Bit 1 Reserved (R)

Bit 0 8/9 Dot Clock (DC)
 0 = 9 dot wide character clock
 1 = 8 dot wide character clock

SEQ02: Enable Write Plane Register

Read/ Write Address: 3C5h, Index: 02h

Power-on Default: 00h

7	6	5	4	3	2	1	0
RESERVED				ENABLE WRITING			

Bit 7:4 Reserved

Bit 3:0 Enable Writing to Memory Maps 3 through 0 (respectively)
 0 = Disable writing to corresponding plane
 1 = Enable writing to corresponding plane

SEQ03: Character Map Select Register

Read/ Write Address: 3C5h, Index: 03h

Power-on Default: 00h

7	6	5	4	3	2	1	0
RESERVED		SCM	SCMB	SCMA	SCMA	SCMB	SCMB

Bit 7:6 Reserved**Bit 5,3,2** Select Character Map A (SCMA)

This value select the portion of plane 2 used to generate text character when bit 3 of this register = 0, according to the following table:

Bit 5,3,2	Font Table Location
000	First 8K of plane 2
100	Second 8K of plane 2
001	Third 8K of plane 2
101	Fourth 8K of plane 2
010	Fifth 8K of plane 2
110	Sixth 8K of plane 2
011	Seventh 8K of plane 2
111	Eighth 8K of plane 2

Bit 4,1,0 Select Character Map B (SCMB)

This value select the portion of plane 2 used to generate text character when bit 3 of this register = 1, according to the same table as character Map A

SEQ04: Memory Mode Register

Read/ Write Address: 3C5h, Index: 04h

Power-on Default: 00h

7	6	5	4	3	2	1	0
RESERVED				CM	SSA	EVM	R

Bit 7:4 Reserved**Bit 3** Chained 4 Map (CM)

0 = Enable odd/even mode

1 = Enable Chain 4 mode. Uses the two lower bits of CPU address to select plane in video memory as follows:

MA1	MA0	Plane Selected
0	0	0
0	1	1
1	0	2
1	1	3

Bit 2 Select Sequential Addressing Mode (SSA). This bit affects only CPU write data accesses into video memory. Bit 3 of this register must be 0 for this bit to be effective.

0 = Enable the odd/even addressing mode. Even addresses access planes 0 and 2, and odd addresses access plane 1 and 3

1 = Enable system to use a sequential addressing mode

Bit 1 Extended Video Memory Enable (EVM)

0 = Memory access restricted to 16/32K

1 = Enable extended video memory access. Allows complete memory access to 256K

Bit 0 Reserved (R)

CRTC Controller Registers

The CRTC registers are located at two locations in I/O address space. These registers are accessed by first writing to the index register (3?4h), then writing to the data register (3?5h). The I/O address is either 3Bxh or 3Dxh depending on bit 0 of the Miscellaneous Output Register at 3C2h.

CRTX: CRTC Controller Index Register

Read/Write Address: 3?4h

Power-on Default: 00h

This register is loaded with a binary value that indexes the CRTC controller register where data is to be accessed.

7	6	5	4	3	2	1	0
RESERVED			CRTC ADDRESS INDEX				

Bit 7:5 Reserved

Bit 4:0 CRTC Address Index

These bits specify the CRTC register to be addressed. Its value is programmed in hexadecimal.

CRT00: Horizontal Total Register

Read/Write Address: 3?5h, Index 00h

Power-on Default: Undefined

This register defines the number of character clocks from HSYNC going active to the next HSYNC going active.

7	6	5	4	3	2	1	0
HORIZONTAL TOTAL							

Bit 7:0 Horizontal Total
This value = (number of character clocks per scan line) - 5.

CRT01: Horizontal Display End Register

Read/Write Address: 3?5h, Index 01h
Power-on Default: Undefined

This register defines the number of character clocks for one horizontal line active display. This register is locked when FPR33 (SC5h, index 33) bit 5 = 1. Please refer to FPR33 register.

7	6	5	4	3	2	1	0
HORIZONTAL DISPLAY ENABLE							

Bit 7:0 Horizontal Display Enable
This value = (number of character clocks during active display) - 1.

CRT02: Horizontal Blank Start Register

Read/Write Address: 3?5h, Index 02h
Power-on Default: Undefined

This register defines the number of character clocks at which horizontal ~Blank is asserted.

7	6	5	4	3	2	1	0
HORIZONTAL BLANK START							

Bit 7:0 Horizontal Blank Start
This value = character value at which ~Blank signal becomes active.

CRT03: Horizontal Blank End Register

Read/Write Address: 3?5h, Index 03h
Power-on Default: Undefined

This register defines the display enable skew and pulse width of ~Blank signal.

7	6	5	4	3	2	1	0
R	DISPLAY ENABLE	HORIZONTAL BLANK END					

Bit 7 Reserved**Bit 6:5** Display Enable Skew. These 2 bits define the display enable signal skew timing in relation to horizontal synchronization pulses.

DESKW1	DESKW0	Character Clock Skew
0	0	0
0	1	1
1	0	2
1	1	3

Bit 4:0 Horizontal Blank End
Horizontal Blank End has a 6-bit value. This register contains the least significant 5-bits of this value. Bit 6 of this value is at CRTC index 05 bit 7.

CRT04: Horizontal Sync Pulse Start Register

Read/Write Address: 3?5h, Index 04h
Power-on Default: Undefined

This register is used to adjust screen position horizontally and to specify the position at which HSYNC is active.

7	6	5	4	3	2	1	0
HORIZONTAL SYNC PULSE START							

Bit 7:0 Horizontal Sync Pulse Start
This value = character clock count value at which HSYNC becomes active.

CRT05: End Horizontal Sync Pulse Register

Read/Write Address: 3?5h, Index 05h
Power-on Default: Undefined

This register defines the horizontal sync skew and pulse width of HSYNC signal.

7	6	5	4	3	2	1	0
HBE	HSS		HORIZONTAL SYNC END				

Bit 7 Horizontal Blank End Bit 5. This bit is End Horizontal Blank Bit 5. (HBE)**Bit 6:5** Horizontal Sync Skew. (HSS)
These 2-bits define the HSYNC signal skew timing in relation to horizontal synchronization pulses.

HSSKW1	HSSKW0	Character Clock Skew
0	0	0
0	1	1
1	0	2
1	1	3

Bit 4:0 Horizontal Sync End
Horizontal Sync End has a 5-bit value. This value defines the character clock counter value at which HSYNC signal becomes inactive.

CRT06: Vertical Total Register

Read/Write Address: 3?5h, Index 06h

Power-on Default: Undefined

This register defines the number of scan lines from VSYNC going active to the next VSYNC going active. Vertical total has a 11-bit value. Bit 8 of this value is located at CRT07 bit 0. Bit 9 of this value is located at CRT07 bit 5. Bit 10 of this value is located at CRT30 bit 3.

7	6	5	4	3	2	1	0
VERTICAL TOTAL							

Bit 7:0 Vertical Total
Vertical Total has a 11-bit value. This register contains the least significant 8-bits of this value. This value = (number of scan lines from VSYNC going active to the next VSYNC) - 2. Bit 8 is in CRT07 bit 0. Bit 9 is in CRT 07 bit 5. Bit 10 is in CRT30 bit 3.

CRT07: Overflow Vertical Register

Read/ Write Address: 3?5hIndex: 07h

Power-on Default: Undefined

This register specifies the CRTC vertical overflow registers.

7	6	5	4	3	2	1	0
VSS	VDE	VT	LC	VBS	VSS	VDE	VT

Bit 7 Vertical Sync Start Bit 9 (VSS)

Bit 6 Vertical Display Enable End Bit 9. This bit is locked when FPR33 (SC5h, index 33) bit 5 = 1. Please refer to FPR33 register. (VDE)

Bit 5 Vertical Total Bit 9 (VT)

Bit 4 Line Compare Bit 8 (LC)

Bit 3 Vertical Blank Start Bit 8 (VBS)**Bit 2** Vertical Sync Start Bit 8 (VSS)**Bit 1** Vertical Display Enable End Bit 8. This bit is locked when FPR33 (SC5h, index 33) bit 5 = 1. (VDE)**Bit 0** Vertical Total Bit 8 (VT)

CRT08: Preset Row Scan Register

Read/Write Address: 3?5h, Index 08h

Power-on Default: Undefined

This register is used for panning and text scrolling.

7	6	5	4	3	2	1	0
R	BYTE PLANNING		PRESET ROW SCAN COUNT				

Bit 7 Reserved (R)**Bit 6:5** Byte Panning Control. These 2-bits controls the number of bytes to pan.

BPC1	BPC0	Operation
0	0	Normal
0	1	1 Byte left shift
1	0	2 Bytes left shift
1	1	3 Bytes left shift

Bit 4:0 Preset Row Scan Count

These bits preset the vertical row scan counter once after each vertical retrace. This counter is automatically incremented by 1 after each horizontal sync period. Once the maximum row scan count is reached, this counter is cleared. This is useful for smoothing vertical text scrolling.

CRT09: Maximum Scan Line Register

Read/Write Address: 3?5h, Index 09h

Power-on Default: Undefined

This register defines the maximum number of scan lines per character row and provides one scanning control and two overflow bits

7	6	5	4	3	2	1	0
EDS	LC	VB	MAXIMUM SCAN LINE				

Bit 7 Enable Double Scan (EDS)
0 = Normal Operating

1 = Enable Double Scan. The row scan counter is clocked at half of the horizontal scan rate.

Bit 6 Line Compare Register Bit 9 (LC)

Bit 5 Vertical Blank Start Register Bit 9 (VB)

Bit 4:0 Maximum Scan Line
This value equals to the total number of scan lines per character row - 1

CRT0A: Cursor Start Scan Line Register

Read/Write Address: 3?5h, Index 0Ah

Power-on Default: Undefined

This register defines the row scan of a character line at which the cursor begins and enable/disable cursor.

7	6	5	4	3	2	1	0
RESERVED		EC	CURSOR START SCAN LINE				

Bit 7:6 Reserved

Bit 5 Enable Cursor (EC)
0 = Cursor is on
1 = Cursor is off

Bit 4:0 Cursor Start Scan Line
This value equals to the starting cursor row within the character box. If this value is programmed with a value greater than the Cursor End Scan Line Register (3?5h, index 0Bh), no cursor will be displayed.

CRT0B: Cursor End Scan Line Register

Read/Write Address: 3?5h, Index 0Bh

Power-on Default: Undefined

This register defines the row scan of a character line at which the cursor begins and enable/disable cursor.

7	6	5	4	3	2	1	0
R	CURSOR SKEW		CURSOR END SCAN LINE				

Bit 7 Reserved (R)

Bit 6:5 Cursor Skew. These 2 bits defines the cursor delay skew, which moves the cursor to the right, in character clock.

CSKW1	CSKW0	Character Clock Skew
0	0	0
0	1	1
1	0	2
1	1	3

Bit 4:0 Cursor End Scan Line

This value equals to the ending cursor row within the character box. If this value is programmed with a value less than the Cursor Start Scan Line Register (3?5h, index 0Ah), no cursor will be displayed.

CRT0C: Display Start Address High Register

Read/Write Address: 3?5h, Index 0Ch

Power-on Default: Undefined

This register defines the high order first address after a vertical retrace at which the display on the screen begins on each screen refresh. This value is a 19-bit value. Bit [18:16] are located in CRT30 bit [6:4]. Bit [7:0] are located in CRT0D.

7	6	5	4	3	2	1	0
DIPLAY START ADDRESS [15:8]							

Bit 7:0 Display Start Address [15:8]

This register is the high order byte of the address [15:8].

CRT0D: Display Start Address Low Register

Read/Write Address: 3?5h, Index 0Dh

Power-on Default: Undefined

This register defines the low order first address after a vertical retrace at which the display on the screen begins on each screen refresh. This value is a 19-bit value. Bit [18:16] are in CRT30 bit [6:4]. Bit [15:8] are in CRT0C.

7	6	5	4	3	2	1	0
START ADDRESS [7:0]							

Bit 7:0 Start Address [7:0]

This register is the low order byte of the address [7:0].

CRT0E: Cursor Location High Register

Read/Write Address: 3?5h, Index 0Eh

Power-on Default: Undefined

This register defines the high order cursor location address. This value is a 19-bit value along with CRT30 bit[6:4] are the high order bits of the address.

7	6	5	4	3	2	1	0
CURSOR LOCATION HIGH							

Bit 7:0 Cursor Location High
This register is the high order byte of the cursor location address.

CRT0F: Cursor Location Low Register

Read/Write Address: 3?5h, Index 0Fh
Power-on Default: Undefined

This register defines the low order cursor location address.

7	6	5	4	3	2	1	0
CURSOR LOCATION LOW							

Bit 7:0 Cursor Location Low
This register is the low order byte of the cursor location address.

CRT10: Vertical Sync Pulse Start Register

Read/Write Address: 3?5h, Index 10h
Power-on Default: Undefined

This register is used to adjust screen position vertically and to specify the position at which VSYNC is active. Bit 10 of this value is in CRT30 bit 0. Bit 9 of this value is in CRT07 bit 7. Bit 8 of this value is in CRT07 bit 2.

7	6	5	4	3	2	1	0
VERTICAL SYNC PULSE START							

Bit 7:0 Vertical Sync Pulse Start
Vertical Sync Start has a 11-bit value. This register contains the least significant 8 bits of this value.
This value = number of scan lines at which VSYNC becomes active.

CRT11: Vertical Sync Pulse End Register

Read/Write Address: 3?5h, Index 11h
Power-on Default: 0xh.

This register is used to control vertical interrupt, vertical sync end CRT0-7 Write protect.

7	6	5	4	3	2	1	0
LW	RCS	DVI	CVI	VERTICAL SYNC PULSE END			

- Bit 7** Lock writing to CRTC registers: CRT00-07. (LW)
0 = Enable writing to CRTC registers are
1 = Disable writing to CRTC registers, except CRT07 bit 4 (line compare)
- Bit 6** Refresh Cycle Select (3/5) (RCS)
0 = 3 DRAM refresh cycles per horizontal scan line
1 = 5 DRAM refresh cycles per horizontal scan line
- Bit 5** Disable Vertical Interrupt (DVI)
0 = vertical retrace interrupt enabled
1 = vertical retrace interrupt disabled
- Bit 4** Clear Vertical Interrupt (CVI)
0 = vertical retrace interrupt is cleared
1 = vertical retrace interrupt. This allows an interrupt to be generated at the end of active vertical display.
- Bit 3:0** Vertical Sync Pulse End
This value = number of scan lines at which VSYNC becomes inactive.

CRT12: Vertical Display End Register

Read/Write Address: 3?5h, Index 12h
Power-on Default: Undefined

This register defines the number of scan line where the display on the screen ends. Bit 10 of this value is in CRT30 bit 2. Bit 9 of this value is in CRT07 bit 6. Bit 8 of this value is in CRT07 bit 1. This register is locked when FPR33 (SC5h, index 33) bit 5 = 1. Please refer to FPR33 register.

7	6	5	4	3	2	1	0
VERTICAL DISPLAY END							

- Bit 7:0** Vertical Display End
Vertical Display End has a 11-bit value. This register contains the least significant 8-bits of this value.
This value = (number of scan lines during active display) - 1.

CRT13: Offset Register

Read/Write Address: 3?5h, Index 13h
Power-on Default: Undefined

7	6	5	4	3	2	1	0
LOGICAL SCREEN WIDTH							

This register defines the logical line width of the screen. The starting memory address for the next display row is larger than the current row by two (in byte mode), four (in word mode), or eight (in double word mode) times this offset.

Bit 7:0 Logical Screen Width
Logical Screen Width has a 10-bit value. This register contains the least significant 8-bits of this value. The addressing mode is specified by bit 6 of CRT14 and bit 3 of CRT17.

CRT14: Underline Location Register

Read/Write Address: 3?5h, Index 14h
Power-on Default: Undefined

This register defines the horizontal row scan position of underline and display buffer addressing modes.

7	6	5	4	3	2	1	0
R	DWS	CS	UNDER LINE LOCATION				

Bit 7 Reserved (R)

Bit 6 Double Word Mode Select (DWS)
0 = the memory address are byte or word addresses
1 = the memory address are double word addresses

Bit 5 Count by 4 Select (CS)
0 = the memory address counter depends on bit 3 of CRT17
1 = the memory address counter is incremented every four character clocks

Bit 4:0 Under Line Location
Under Line Location has a 5-bit value. This value = (scan line count of a character row on which an underline occurs) - 1.

CRT15: Vertical Blank Start Register

Read/Write Address: 3?5h, Index 15h
Power-on Default: Undefined

This register defines the number of scan lines at which vertical blank is asserted. Bit 10 of this value is in CRT30 bit 1. Bit 9 of this value is in CRT09 bit 5. Bit 8 of this value is in CRT07 bit 3.

7	6	5	4	3	2	1	0
VERTICAL BLANK START							

- Bit 7:0** Vertical Blank Start
Vertical Blank Start has a 11-bit value. This register contains the least significant 8-bits of this value. This value = (scan line count at which vertical blank signal becomes active) - 1.

CRT16: Vertical Blank End Register

Read/Write Address: 3?5h, Index 16h
Power-on Default: Undefined

This register defines the number of scan lines at which vertical blank is de-asserted.

7	6	5	4	3	2	1	0
VERTICAL BLANK END							

- Bit 7:0** Vertical Blank End
Vertical Blank End is a 8-bit value. This value = [(scan line count at which vertical blank signal becomes active) - 1] + (desired width of vertical blanking pulse in scan lines)

CRT17: CRT Mode Control Register

Read/Write Address: 3?5h, Index 17h
Power-on Default: Undefined

This register defines the controls for CRT mode.

7	6	5	4	3	2	1	0
HR	BAS	AW	R	WS	HCS	EGA	CGA

- Bit 7** ~RST Hardware Reset for Horizontal and Vertical Sync (HR)
0 = horizontal and vertical sync outputs inactive
1 = horizontal and vertical sync outputs active
- Bit 6** Byte Address Mode Select (BAS)
0 = word address mode. All memory address counter bits shift down by one bit and the MSB of the address counter appears on the LSB
1 = byte address mode
- Bit 5** Address Wrap is useful in implementing CGA mode. (AW)
0 = In word address mode, memory address counter bit 13 appears on the memory address output signal of the CRT controller and the video memory address wraps around at 16KB.
1 = In word address mode, memory address counter bit 15 appears on the memory address output bit 0 signal of the CRT controller.
- Bit 4** Reserved (R)
- Bit 3** Word Mode Select (WS)

0 = byte mode addressing is selected and memory address counter is clocked by the character clock input

1 = word mode addressing is selected and memory address counter is clocked by the character clock divided by two.

Bit 2 Horizontal Retrace Clock Select (HCS)
0 = select horizontal retrace clock rate
1 = select horizontal retrace clock rate divided by two.

Bit 1 EGA Emulation (EGA)
0 = Row scan counter bit 1 is replaced by memory address bit 14 during active display time
1 = Memory address bit 14 appear son the memory address output bit 14 signal of the CRT controller.

Bit 0 CGA Emulation (CGA)
0 = Row scan counter bit 0 is replaced by memory address bit 13 during active display time
1 = Memory address bit 13 appears on the memory address output bit 13 signal of the CRT controller.

CRT18: Line Compare Register

Read/Write Address: 3?5h, Index 18h
Power-on Default: Undefined

This register is used to implement a split screen function. When the scan line counter value is equal to the content of this register, the memory address counter is cleared to 0.

7	6	5	4	3	2	1	0
LINE COMPARE REGISTER							

Bit 7:0 Line Compare Register
This value = number of scan lines at which the screen is split into screen 1 and screen 2.

CRT22: Graphics Controller Data Latches Readback Register

Read Only Address: 3?5h, Index 22h
Power-on Default: Undefined

This register is used to read the CPU latches in the graphics controller.

7	6	5	4	3	2	1	0
GRAPHICS CONTROLLER CPU DATA LATCHES							

Bit 7:0 Graphics Controller CPU Data Latches
Bits 1-0 of GR4 select the latch number N (3-0) of the CPU Latch.

CRT24: Attribute Controller Toggle Readback Register

Read Only Address: 3?5h, Index 24h

Power-on Default: Undefined

This register is used to provide access to the attribute controller toggle.

7	6	5	4	3	2	1	0
ACS	RESERVED						

Bit 7 Attribute Controller Index Select (ACS)
 0 = the attribute controller reads or writes an index value on the next access
 1 = the attribute controller reads or writes a data value on the next access

Bit 6:0 Reserved

CRT26: Attribute Controller Index Readback Register

Read Only Address: 3?5h, Index 26h
 Power-on Default: Undefined

This register is used to provide access to the attribute controller index.

7	6	5	4	3	2	1	0
RESERVED		VES	ATTRIBUTE CONTROLLER INDEX				

Bit 7:6 Reserved

Bit 5 Video Enable Status (VES)

This bit provides status of the video display enable bit in Attribute Controller (3C0h) index bit 5.

Bit 4:0 Attribute Controller Index

This value is the attribute controller index data at 3C0h.

Graphics Controller Registers

The graphics controller registers are located at a two byte I/O address space. The registers are accessed by first writing an index to 3CEh and followed by writing a data to 3CFh.

GRXX: Graphics Controller Index Register

Read/Write Address: 3CEh
 Power-on Default: Undefined

This register is loaded with a binary value that indexes the graphics controller register where data is to be accessed.

7	6	5	4	3	2	1	0
RESERVED				GRAPHICS CONTROLLER			

Bit 7:4 Reserved

Bit 3:0 Graphics Controller Address Index
These bits specify the graphics controller register to be addressed. Its value is programmed in hexadecimal.

GRX00: Set/Reset Register

Read/Write Address: 3CFh, Index: 00h.
Power-on Default: Undefined

This register represents the value written to all 8-bits of the corresponding memory planes when CPU executes a memory write in write mode 0.

7	6	5	4	3	2	1	0
RESERVED				SET/RESET PLANE			

Bit 7:4 Reserved

Bit 3:0 Set/Reset Plane3:0
In write mode 0, the set/reset data can be enabled on the corresponding bit of the bit of the Enable Set/Reset Data register. These bits become the color value for CPU memory write operations.

GRX01: Enable Set/Reset Register

Read/Write Address: 3CFh, Index: 01h.
Power-on Default: Undefined

This register enable the set/reset register in write mode 0.

7	6	5	4	3	2	1	0
RESERVED				ENABLE SET/RESET PLANE			

Bit 7:4 Reserved

Bit 3:0 Enable Set/Reset Plane3:0
In write mode 0, the enable set/reset bits allow writing to the corresponding planes with the data in set/reset register. A logical 0 disables the set/reset data in a plane, and that plane is written with the value of CPU write data.

GRX02: Color Compare Register

Read/Write Address: 3CFh Index: 02h.
Power-on Default: Undefined

This register is used to compare with the CPU memory read data. This register works in conjunction with the Color Don't Care Register.

7	6	5	4	3	2	1	0
RESERVED				COLOR COMPARE PLANE			

Bit 7:4 Reserved

Bit 3:0 Color Compare Plane [3:0]
These bits represent the reference color used to compare each pixel in corresponding plane. A logical 1 is returned in each plane bit position when color matches.

GRX03: Data Rotate/ROP Register

Read/Write Address: 3CFh Index: 03h.
Power-on Default: Undefined

This register is used to control rotation and raster operations.

7	6	5	4	3	2	1	0
RESERVED			ROS		ROTATE COUNT		

Bit 7:5 Reserved

Bit 4:3 Raster Operations Select (ROS)
00 = No operation
01 = Logical AND with latched data
10 = Logical OR with latched data
11 = Logical XOR with latched data

Bit 2:0 Rotate Count
These bits specify the number of bit positions of rotation to the right. Data written by the CPU is rotated in write mode 0. To write non-rotated data, the CPU must present a count with 0.

GRX04: Read Plane Select Register

Read/Write Address: 3CFh Index: 04h.
Power-on Default: Undefined

This register selects which memory plane the CPU data is reading from in read mode 0. This register has no effect on the color compare read mode (read mode 1). In odd/even mode, bit 0 is ignored.

7	6	5	4	3	2	1	0
RESERVED						READ PLANE	

Bit 7:2 Reserved

Bit 1:0 Read Plane Select is as follows:
 00 = Plane 0
 01 = Plane 1
 10 = Plane 2
 11 = Plane 3

GRX05: Graphics Mode Register

Read/Write Address: 3CFh Index: 05h.

Power-on Default: Undefined

This register is selects which memory plane the CPU data is reading from in read mode 0. This register has no effect on the color compare read mode (read mode 1). In odd/even mode, bit 0 is ignored.

7	6	5	4	3	2	1	0
R	CS	OES	OEA	ERC	R	WRITING MODE	

Bit 7 Reserved (R)

Bit 6 256 Color Shift Mode Select (CS)
 0 = Enable bit 5 of this register to control loading of the shift registers.
 1 = The shift registers are loaded in a manner that support the 256 color mode.

Bit 5 Odd/Even Shift Mode Select (OES)
 0 = Normal shift mode
 1 = The video shift registers are directed to format the serial data stream with even numbered bits from both planes on the even numbered planes and odd numbered bits from both planes on the odd planes.

Bit 4 Odd/Even Addressing Select (OEA)
 0 = Normal addressing
 1 = CGA Odd/even addressing mode is selected. Even CPU addresses access plane 0 and 2, while odd CPU addresses access plane 1 and 3.

Bit 3 Enable Read Compare (ERC)
 0 = System read data from memory planes selected by read map select register (3CFh index 04h). This is called read mode 0.
 1 = System read the results of logical comparison between the data in 4 memory planes selected by the Color Don't Care Register and the Color Compare Register. The results is a 1 for a match and 0 for a mismatch on each pixel. This is called read mode 1.

Bit 2 Reserved (R)

Bit 1:0 Write Mode Select

00 = Write mode 0. Each of four video planes is written with CPU data rotated by the number of counts in rotate register. If Set/Reset register is enabled for any of the four planes, the corresponding planes is written with the data stored in the Set/Reset register.

01 = Write mode 1. Each of four video planes is written with CPU data in the processor latches. These latches are loaded during previous CPU read operations. Raster operation, rotate count, Set/Reset data, enable Set/Reset data and bit mask registers are ignored.

10 = Write mode 2. Video planes [3:0] are written with the value of CPU write data [3:0]. The 32-bit output from the four planes is then operated on by the Bit Mask register and the resulting data are written into the four planes. The Set/Reset, Enable Set/Reset and Rotate Count registers are ignored.

11 = Write mode 3. Each of the four video planes is written with 8-bit of the color value in the Set/Reset register for the corresponding plane. The bit-position-enable field is formed with the logical AND of the Bit Mask register and rotated CPU data. The Enable Set/Reset register is ignored.

GRX06: Graphics Miscellaneous Register

Read/Write Address: 3CFh Index: 06h.

Power-on Default: Undefined

This register controls video memory addressing.

7	6	5	4	3	2	1	0
RESERVED				MEMORY MAP		OES	GMS

Bit 7:4 Reserved

Bit 3:2 Memory Map Mode. These bits control the address mapping of video memory into the CPU address space.

00 = A0000h to BFFFFh (128KB)

01 = A0000h to AFFFFh (64KB)

10 = B0000h to B7FFFh (32KB)

11 = B8000h to BFFFFh (32KB)

Bit 1 Odd/Even Mode Select (OES)

0 = CPU address bit A0 is the memory address bit MA0

1 = CPU address A0 is replaced by a higher order address bit. A0 is then used to select odd or even maps. A0=0, selects Map 2 or 0; A0 = 1, select Map 3 or 1.

Bit 0 Graphics Mode Select (GMS)

0 = Select Text mode

1 = Select Graphics mode

GRX07: Color Don't Care Plane Register

Read/Write Address: 3CFh Index: 07h.

Power-on Default: Undefined

This register controls whether the corresponding bit of the Color Compare Register, GRX02, is to be ignored or used for color comparison. This register is used with GRX02 for Read Mode 1 accesses.

7	6	5	4	3	2	1	0
RESERVED				COMPARE PLANE SELECT			

Bit 7:4 Reserved

Bit 3:0 Compare Plane Select

0 = The corresponding color plane becomes a don't care plane when the CPU read from the video memory is performed in read mode 1.

1 = The corresponding color plane is used for color comparison with the data in the Color Compare Register, GRX02.

GRX08: Bit Mask Register

Read/Write Address: 3CFh Index: 08h.

Power-on Default: Undefined

This register controls bit mask operations which applies simultaneously to all four maps. The data written into memory in this case is the data which was read in the previous cycle, and was stored in the processor latches. Any bit programmed to 1 allows unimpeded writes to the corresponding bits in the plane.

7	6	5	4	3	2	1	0
BIT MASK							

Bit 7:0 Bit Mask

0 = corresponding bit of each plane in memory is set to the corresponding bit in the processor latches.

1 = corresponding bit of each plane in memory is set as specified by other conditions.

Attribute Controller Registers

The attribute controller registers are located at the same byte I/O address for writing address and data. The Attribute Index Register has an internal flip-flop rather than an input bit to control the selection of the address and data registers. Reading the Input Status Register 1 at Port 3?Ah clears the flip-flop and selects the Address Register, which is read at address 3C1h and written at address 3C0h. Once the Address Register has been loaded with an index, the next write operation to 3C0h loads the Data Register. The flip-flop toggles between the Address and the Data Register after every write to address 3C0h, but does not toggle for reads from address 3C1h. Furthermore, the attribute controller index register is read at 3C0h, and the attribute controller data register is read at address 3C1h.

ATRX: Attribute Controller Index Register

Read/Write Address: 3C0h

Power-on Default: Undefined

This register is loaded with a binary value that indexes the attribute controller register where data is to be accessed.

7	6	5	4	3	2	1	0
RESERVED		PAS	ATTRIBUTE CONTROLLER ADDRESS				

Bit 7:6 Reserved

Bit 5 Palette Address Source (PAS)

0 = Disable internal color palette outputs and video outputs to allow CPU access to color palette registers

1 = Enable internal color palette and normal video translation.

Bit 4:0 Attribute Controller Address

A binary value that points to the attribute controller register where data is to be written.

ATR00-0F: Palette Register

Read/Write Address: 3C1h/3C0h Index 00h - 0Fh.

Power-on Default: Undefined

This register is loaded with a binary value that indexes the attribute controller register where data is to be accessed.

7	6	5	4	3	2	1	0
RESERVED		PALETTE COLORS					

Bit 7:6 Reserved

Bit 5:0 Palette Colors

0 = corresponding pixel color is de-selected

1 = corresponding pixel color is enabled

ATR10: Attribute Mode Control Register

Read/Write Address: 3C1h/3C0h Index: 10h.

Power-on Default: 00h

This register controls the attribute mode of the display function.

7	6	5	4	3	2	1	0
VID	CS	PPE	R	BIS	LGC	MCE	TGM

Bit 7 VID5, VID4 Select (VID)

0 = VID5 and VID4 palette register outputs are selected

1 = Color Select Register Port 3C1h/3C0h, Index 14h, bit 1 and bit 0 are selected for outputs.

Bit 6 256 Color Select (CS)

0 = Disable 256 color mode pixel width. PCLK rate = internal dot clock rate.
1 = Enable 256 color mode pixel width. PCLK rate = internal dot clock rate / 2

- Bit 5** Pixel Panning Enable (PPE)
0 = Line compare will have no effect on the output of the pixel panning register
1 = Forces the output of the pixel panning register to 0 after matching line compare until VSYNC is active
- Bit 4** Reserved (R)
- Bit 3** Blinking and Intensity Select (BIS)
0 = Select background intensity from the text attribute byte.
1 = Select blink attribute in text modes
- Bit 2** Line Graphics Character Enable (LGC)
0 = Forces the ninth dot to be the same color as the background in line graphics character codes.
1 = Enable special line graphics character codes.
- Bit 1** Mono/Color Emulation (MCE)
0 = Select color display text attributes
1 = Select monochrome display text attributes
- Bit 0** Text /Graphics Mode Select (TGM)
0 = Select text attribute control mode
1 = Select graphics control mode

ATR11: Overscan Color Register

Read/Write Address: 3C1h/3C0h Index: 11h.
Power-on Default: 00h

This register controls the overscan or border color. This register will be locked if CRT3C register (3?5h, index 3Ch) bit 5 is set to 1. Please refer to CRT3C register for details.

7	6	5	4	3	2	1	0
OVERSCAN COLOR REGISTER							

Bit 7:0 OverScan Color register determines the overscan or border color displayed on the CRT screen.

ATR12: Color Plane Enable Register

Read/Write Address: 3C1h/3C0h Index: 12h.
Power-on Default: 00h

This register enables the respective video memory color plan 0-3 and selects the video color outputs to be read back in the display status.

7	6	5	4	3	2	1	0
RESERVED		VIDEO SATUS		COLOR PLANE ENABLE			

Bit 7:6 Reserved

Bit 5:4 Video Status Multiplexer. These bits select two out of the 8 color outputs which can be read by the Input Status Register 1 at port 3?Ah, bit 5 and bit 4.

Color Plane Register		Input Status Register 1	
Bit 5	Bit 4	Bit 5	Bit 4
0	0	VID2	VID0
0	1	VID5	VID4
1	0	VID3	VID1
1	1	VID7	VID7

Bit 3:0 Color Plane Enable
 0 = disable the corresponding color planes. Forces pixel bit to be 0 before it address palette.
 1 = enables the corresponding color planes.

ATR13: Horizontal Pixel Panning Register

Read/Write Address: 3C1h/3C0h Index: 13h.
 Power-on Default: 00h

This register specifies the number of pixels to shift the display data horizontally to the left. Horizontal pixel panning is available in text and graphics modes.

7	6	5	4	3	2	1	0
RESERVED				HORIZONTAL PIXEL PLANNING			

Bit 7:4 Reserved

Bit 3:0 Horizontal Pixel Panning. These 4 bits determine the horizontal left shift of the video data in number of pixels. In the 9 pixel/character text mode, the output can be shifted a maximum shift of 8 pixels. In the 8 pixel/character text mode and all graphics modes, except for 256 color mode, a maximum shift of 7 pixels is allowed. In the 256 color mode, bit 0 of this register must be 0 resulting in only 4 panning positions per display byte. The panning is controlled as follows:

Bits 3:0	9 pixel/character	8 pixel/character	256 color modes
0000	1	0	0
0001	2	1	-
0010	3	2	1

0011	4	3	-
0100	5	4	2
0101	6	5	-
0110	7	6	3
0111	8	7	-
1000	0	-	-

ATR14: Color Select Register

Read/Write Address: 3C1h/3C0h, Index: 14h.

Power-on Default: 00h

This register specifies the high-order bits of video output when pixel padding is enable/disabled for 256 color modes.

7	6	5	4	3	2	1	0
RESERVED				SC7/6		SC5/4	

Bit 7:4 Reserved

Bit 3:2 Select Color 7 and Color 6 (SC7/6)

These are the two most significant bits of the 8 bits color value for video DAC. These are normally used in all modes except 256 color modes.

Bit 1:0 Select Color 5 and Color 4 (SC5/4)

These bits can be substituted for VID5 and VID4 from the palette registers to form the 8-bit color value for video DAC.

RAMDAC Registers

The section describes the RAMDAC registers. Special programming sequences are used to read or write data to and from the RAMDAC.

Writing data to DAC:

Write the color code to DAC Write Address Register at 3C8h.

Three bytes: Red, Green, Blue values are written into DAC Data Register at 3C9h.

Following the third write, the values are transferred to Color Lookup Table.

- The DAC Write Address Register is auto incremented by 1.

Reading data from DAC:

- Write the color code to DAC Read Address Register at 3C7h.
- Three bytes: Red, Green, Blue values are read from the DAC Data Register at 3C9h.

3C6: DAC Mask Register

Read/Write Address: 3C6h

Power-on Default: Undefined

This register is the pixel read mask register to select pixel video output.

7	6	5	4	3	2	1	0
DAC ADDRESS MASK							

Bit 7:0 DAC Address Mask

This field is the pixel mask for palette DAC. When a bit in this field is programmed to 0, the corresponding bit in the pixel data is ignored in looking up an entry in the Color Lookup Table. This register is initialized to FFh by the BIOS during a video mode set.

3C7W: DAC Address Read Register

Write Only Address: 3C7h

Power-on Default: Undefined

This register contains the pointer to one of the 256 palette data registers and is used when reading the color palette. A write to this register causes 11b to be driven out to the RAMDAC output.

7	6	5	4	3	2	1	0
DAC READ ADDRESS							

Bit 7:0 DAC Read Address

After a color code is written into this register, the chip will identify that a DAC read sequence will occur. A read sequence consists of three consecutive byte reads from the RAMDAC data register at 3C9h.

3C7R: DAC Status Register

Read Only Address: 3C7h

Power-on Default: Undefined

This register specifies the DAC Status: read or write cycles.

7	6	5	4	3	2	1	0
RESERVED						DAC STATUS	

Bit 7:2 Reserved**Bit 1:0** DAC Status bits

00 = DAC write operation in progress

11 = DAC read operation in progress

3C8: DAC Address Write Register

Read/Write Address: 3C8h

Power-on Default: Undefined

This register contains the pointer to one of the 256 palette data registers and is during a palette load. A write to this register causes 11b to be driven out to the RAMDAC output.

7	6	5	4	3	2	1	0
DAC WRITE ADDRESS							

Bit 7:0 DAC Write Address

After a color code is written into this register, the chip identifies that a DAC write sequence will occur. A write sequence consists of three consecutive byte reads from the RAMDAC data register at 3C9h.

3C9: DAC Data Register

Read/Write Address: 3C9h

Power-on Default: Undefined

This register is the data port to read or write the contents of the location in the Color Lookup Table pointed to by the DAC Read Address or the DAC Write Address registers. An access to this register will cause 01b to be driven to RAMDAC outputs.

7	6	5	4	3	2	1	0
DAC READ/WRITE DATA							

Bit 7:0 DAC Read/Write Data

These read/write register bits store the Pixel data for the Palette DAC

Chapter 21: Extended SMI Registers

Table 27: Extended SMI Registers Quick Reference

Summary of Registers	Page
<i>System Control Registers</i>	
SCR15: PCI Miscellaneous Control Register	21 - 6
SCR16: Status for Drawing Engine and Video Processor	21 - 7
SCR17: General Graphics Command Register 1	21 - 8
SCR18: General Graphics Command Register 2	21 - 9
SCR19: Interrupt Enable and Mask I	21 - 10
SCR1A: Interrupt Status	21 - 11
SCR1B: Interrupt Status Enable and Mask II	21 - 11
SCR1C: Interrupt Status	21 - 11
SCR1F: Interrupt Mask and Hardware Interrupt Enable	21 - 13
SCR24: Reserved	21 - 13
<i>Power Down Control Registers</i>	
PDR20: Power Down Control for Memory, Flat Panel, PLL, and Video Port	21 - 13
PDR21: Functional Blocks Disable Control	21 - 15
PDR22: LCD Panel Control Select	21 - 16
PDR23: Activity Detection Control Register	21 - 17
PDR24: Power Down Register Select	21 - 18
<i>Flat Panel Registers</i>	
FPR30: Flat Panel Type Select	21 - 18
FPR31: Virtual Refresh and Auto Shut Down Control	21 - 19
FPR32: Dithering Engine Select, Polarity, and Expansion Control	21 - 20
FPR33: Panel Power Sequence and LCD Character/Cursor Blink Control	21 - 21
FPR34: LCD Panel ON/OFF Sequence Select and DSTN LCD Control	21 - 22
FPR3E: DSTN LCD Panel Height- High	21 - 22
FPR3F: DSTN LCD Panel Height- Low	21 - 23
FPR40: Read FIFO1 Start Address Low for LCD Frame Buffer	21 - 23
FPR41: Read FIFO1 Start Address High for LCD Frame Buffer	21 - 24
FPR42: Read FIFO2 Start Address Low for LCD Frame Buffer	21 - 24

Summary of Registers (Continued)	Page
FPR43: Read FIFO2 Start Address High for LCD Frame Buffer	21 - 24
FPR44: Read FIFO1 Offset Value of LCD Frame Bufferv	21 - 25
FPR45: Read FIFO1 Address Offset for LCD Frame Buffer Overflow	21 - 25
FPR46: Write Start Address Low of LCD Frame Buffer	21 - 25
FPR47: Write Start Address High of LCD Frame Buffer	21 - 26
FPR48: Write Offset Value of LCD Frame Buffer	21 - 26
FPR49: LCD Frame Buffer Write Overflow	21 - 26
FPR4A: LCD Read and Write FIFOs Request Level Control	21 - 27
FPR4B: Read FIFO2 Offset Value of LCD Frame Buffer	21 - 27
FPR4C: Read FIFO Offset Value of LCD Frame Buffer Overflow	21 - 28
FPR4D: MSB Read FIFO Address	21 - 28
LCD2: LCD2 Control Register	21 - 28
FPR50: LCD Overflow Register 1 for Virtual Refresh	21 - 29
FPR51: LCD Overflow Register 2 for Virtual Refresh	21 - 29
FPR52: LCD Horizontal Total for Virtual Refresh	21 - 30
FPR53: LCD Horizontal Display Enable for Virtual Refresh	21 - 30
FPR54: LCD Horizontal Sync Start for Virtual Refresh	21 - 30
FPR55: LCD Vertical Total for Virtual Refresh	21 - 31
FPR56: LCD Vertical Display Enable for Virtual Refresh	21 - 31
FPR57: LCD Vertical Sync Start for Virtual Refresh	21 - 32
FPR58: EMI Control Register	21 - 32
FPR59: Panel M-Signal Control Register	21 - 32
FPR5A: SYNC Pulse-widths Adjustment	21 - 33
FPRA0: Panel HW Video Control	21 - 33
FPRA1: Panel Video Color Key	21 - 34
FPRA2: Panel Video Color Key	21 - 34
FPRA3: Panel Video Color Key Mask	21 - 34
FPRA4: Panel Video Color Key Mask	21 - 35
FPRA5: Panel Video Red Constant	21 - 35
FPRA6: Panel Video Green Constant	21 - 35
FPRA7: Panel Video Blue Constant	21 - 35
FPRA8: Panel Video Top Boundary	21 - 36
FPRA9: Panel Video Left Boundary	21 - 36
FPRAA: Panel Video Bottom Boundary	21 - 36
FPRAB: Panel Video Right Boundary	21 - 36
FPRAC: Panel Video Top and Left Boundary Overflow	21 - 37
FPRAD: Panel Video Bottom and Right Boundary Overflow	21 - 37

Summary of Registers (Continued)	Page
FPRAE: Panel Video Vertical Stretch Factor	21 - 37
FPRAF: Panel Video Horizontal Stretch Factor	21 - 38
<i>Memory Control Registers</i>	
MCR60: Memory Control	21 - 38
MCR61: Memory Bank Address High	21 - 39
MCR62: Memory Type and Timing Control	21 - 39
MCR76: Memory Type and Timing Control	21 - 39
<i>Clock Control Registers</i>	
CCR65: TV Encoder Control Register	21 - 41
CCR66: RAM Control and Function On/Off Register	21 - 42
CCR67: For Test Purpose Only	21 - 43
CCR68: Clock Control 1	21 - 43
CCR69: Clock Control 2	21 - 44
CCR6A: MCLK Numerator Register	21 - 45
CCR6B: MCLK Denominator Register	21 - 46
CCR6C: VCLK Numerator Register	21 - 46
CCR6D: VCLK Denominator Register	21 - 46
CCR6E: VCLK2 Numerator Register	21 - 47
CCR6F: VCLK2 Denominator Register	21 - 47
CCR7A-CCR7C: TV and RAMDAC Testing Power	21 - 48
CCR7D: Control Registers for TV and RAMDAC Testing	21 - 48
<i>General Purpose Registers</i>	
GPR70: Scratch Pad Register 1	21 - 49
GPR71: Scratch Pad Register 2	21 - 49
GPR72: User Defined Register 1 for DDC2/ I2C	21 - 49
GPR73: User Defined Register 2	21 - 50
GPR74: Scratch Pad Register 3	21 - 51
GPR75: Scratch Pad register 4	21 - 51
<i>Pop-up Icon and Hardware Cursor Registers</i>	
PHR80: Pop-up Icon and Hardware Cursor Pattern Location Low	21 - 51
PHR81: Hardware Cursor Enable & PI/HWC Pattern Location High	21 - 52
<i>Pop-up Icon Registers</i>	
POP82: Pop-up Icon Control	21 - 52
POP83: Reserved	21 - 53
POP84: Pop-up Icon Color 1	21 - 53
POP85: Pop-up Icon Color 2	21 - 53
POP86: Pop-up Icon Color 3	21 - 53

Summary of Registers (Continued)	Page
POP90: Pop-up Icon Start X - Low	21 - 54
POP91: Pop-up Icon Start X - High	21 - 54
POP92: Pop-up Icon Start Y - Low	21 - 54
POP93: Pop-up Icon Start Y - High	21 - 55
<i>Hardware Cursor Registers</i>	
HCR88: Hardware Cursor Upper Left X Position - Low	21 - 55
HCR89: Hardware Cursor Upper Left X Position- High	21 - 55
HCR8A: Hardware Cursor Upper Left Y Position - Low	21 - 56
HCR8B: Hardware Cursor Upper Left Y Position - High	21 - 56
HCR8C: Hardware Cursor Foreground Color	21 - 56
HCR8D: Hardware Cursor Background Color	21 - 57
<i>Extended CRT Control Registers</i>	
CRT30: CRTC Overflow and Interlace Mode Enable	21 - 57
CRT31: Interlace Retrace	21 - 58
CRT32: TV Vertical Display Enable Start	21 - 58
CRT33: TV Vertical Display Enable End - High	21 - 58
CRT34: TV Vertical Display Enable End - Low	21 - 59
CRT35: Vertical Screen Expansion DDA Control Constant - Low	21 - 59
CRT36: Vertical Screen Expansion DDA Control Constant - High	21 - 60
CRT37: Hardware/VGA Test Selection	21 - 60
CRT38: TV Equalization Pulse Control - For use with an external TV encoder only	21 - 60
CRT39: TV Serration Pulse Control - For use with an external TV encoder only	21 - 60
CRT3A: TV Total Timing Control for the Internal TV Encoder	21 - 61
CRT3B: Miscellaneous Lock Register I	21 - 61
CRT3C: Miscellaneous Lock Register II	21 - 62
CRT3D Scratch Register Bits	21 - 62
CRT3E: Scratch Register Bits	21 - 62
CRT3F: Scratch Register Bits	21 - 63
CRT9E: Expansion/Centering Control Register 2	21 - 63
CRT9F: Expansion/Center Control Register 1	21 - 64
CRT90-9B Vertical DDA Look Up Table & CRTA0-A5: Vertical Centering Offset Look Up Table	21 - 65
CRTA0-A5: Vertical Centering Offset Look Up Table	21 - 65
CRTA6: Vertical Centering Offset Register	21 - 66
CRTA7: Horizontal Centering Offset Register	21 - 66
CRTA8-AD: Horizontal Screen Centering Look Up Table	21 - 66
<i>Shadow VGA Registers</i>	

Summary of Registers (Continued)	Page
SVR40: Shadow VGA Horizontal Total	21 - 67
SVR41: Shadow VGA Horizontal Blank Start	21 - 68
SVR42: Shadow VGA Horizontal Blank End	21 - 68
SVR43: Shadow VGA Horizontal Retrace Start	21 - 68
SVR44: Shadow VGA Horizontal Retrace End	21 - 69
SVR45: Shadow VGA Vertical Total	21 - 69
SVR46: Shadow VGA Vertical Blank Start	21 - 69
SVR47: Shadow VGA Vertical Blank End	21 - 70
SVR48: Shadow VGA Vertical Retrace Start	21 - 70
SVR49: Shadow VGA Vertical Retrace End	21 - 70
SVR4A: Shadow VGA Vertical Overflow	21 - 70
SVR4B: Shadow VGA Maximum Scan Line	21 - 71
SVR4C: Shadow VGA Horizontal Display End	21 - 71
SVR4D: Shadow VGA Vertical Display End	21 - 72

Extended SMI Registers

This chapter describes the extended SMI registers including:

- System control registers
- Power down control register
- Flat panel registers
- Memory control registers
- Clock control registers
- General purpose registers
- Popup-Icon and hardware cursor registers
- Extended CRT registers
- Shadow VGA registers

All extended SMI registers are accessed through 3C3h, 3C5h, or 3?5h address. (? = B for monochrome mode and D for color mode) or through their MMI0 location. In order to access extended SMI registers, one must unlock the extended SMI register by writing 010xxxxxb to Lock register (3C3h).

The name of the register consists of the index which the register resides in. For example, SCR10 can be accessed through index 10h of 3C5h.

System Control Registers

All system control registers are controlled by PCI system clock, rather than memory clock (MCLK) or video clock (VCLK). During Lynx3DM power down (when MCLK and VCLK are shutdown), the system control registers can still be accessed through PCI bus.

SCR15: PCI Miscellaneous Control Register

Read Only Address: 3C5h, Index: 15h
Power-on Default: 00h

This register defines the various PCI control registers.

7	6	5	4	3	2	1	0
BRE	ABORT	SDE	DEA	PCI	BIOS	XFER	

Bit 7 PCI Burst Read Enable (BRE)
0 = Disable
1 = Enable. SCR17 bit 5 needs to be set to 1 in order for this bit to take effect. For example, if SCR17 bit 5 = 0, even this bit is set to 1, PCI burst read will not be enabled.

Bit 6 Abort 3D Engine (ABORT)
0 = 3D Engine Normal Operation
1 = Abort 3D Engine Activities

Bit 5 Software Abort Drawing Engine Enable (SDE)
0 = Normal
1 = Enable. This bit has no effect unless bit 4 is set to 1.

Bit 4 Drawing Engine Abort Enable (DEA)
0 = Normal

1 = Enable

Bit 3 PCI Configuration Space: Subsystem ID Lock Enable (PCI)
0 = Disable
1 = Enable

Bit 2 Full range for BIOS access (BIOS)

Bit 1:0 # of Doubleword xfer during burst read = for performance tuning purpose
00 = 2 3D-bit double words
01 = 4 3D-bit double words
IX = 8 3D-bit double words

SCR16: Status for Drawing Engine and Video Processor

Read Only Address: 3C5h, Index: 16h
Power-on Default: Undefined

This register specifies status of Lynx3DM including Drawing Engine Status, Video Processor Status, and Drawing Engine FIFO Available.

7	6	5	4	3	2	1	0
GES	VWI	VWII	DE	DEBS	3DEBS	VPR	VPRCB

Bit 7 Graphics Engine Status (GES)
0 = Indicate current display frame is using the source starting address
1 = Indicate current display frame is not using the source starting address

Bit 6 Video Window I Status (VWI)
0 = Indicate current display frame is using the source starting address
1 = Indicate current display frame is not using the source starting address

Bit 5 Video Window II Status (VWII)
0 = Indicate current display frame is using the source starting address
1 = Indicate current display frame is not using the source starting address

Bit 4 Drawing Engine is Empty and Ready (DE)
0 = Drawing Engine not empty
1 = Drawing Engine empty

Bit 3 2D Drawing Engine Busy Status (DEBS)
0 = Drawing Engine Idle
1 = Drawing Engine Busy

Bit 2 3D Engine Busy Status (3DEBS)
0 = 3D Engine Idle
1 = 3D Engine Busy

Bit 1 VPR53_7 (VPR)
SubPicture Status
0 = Indicate current display frame is using the source starting address
1 = Indicate current display frame is not using the source starting address

Bit 0 VPRcb_7

SCR17: General Graphics Command Register 1

Read/Write Address: 3C5h, Index: 17h

Power-on Default: 00h

This register specifies command controls for Memory Access Disable, PCI bus master status, PCI bus burst write and burst read enable, Big-Endian Swap mode Select, Direct 3D Data Buffer Select, Memory mapped access enable and BIOS ROM size select.

7	6	5	4	3	2	1	0
MAD	PCI	PCI1	BESM	DIRECT3D		MMA	DLT

Bit 7 Memory Access Disable when Drawing Engine Busy (MAD)
0 = Normal
1 = Disable memory access when Drawing Engine is busy

Bit 6 Start PCI Bus Master(PCI)
0 = Stop PCI
1 = Start PCI

Bit 5 PCI burst read and write enable. (PCI1)
0 = Disable
1 = Enable

Bit 4 Big Endian Swap Mode Select (BESM)

Before	[31:24]	[23:16]	[15:8]	[7:0]
↓				
After	[7:0]	[15:8]	[23:16]	[31:24]

0 = Big Endian with byte swap
1 = Big Endian with word swap

Bit 3:2 Direct3D Z-Buffer Data Select

Before	[31:16]	[15:0]
↓		
After	[15:0]	31:16]

00 = Normal (use all 32-bit data)
01 = Use low word [15:0]
10 = Use high word [31:16]
11 = Normal (use all 32-bit data)

Bit 1 Memory Mapped Aperture Select (MMA)
0 = Select Banking Aperture. No Memory Mapped registers access allowed.
1 = Select Memory Mapped Aperture

- Bit 0** Disable Latency Timer (DLT)
 0 = Normal
 1 = Disable latency timer count

SCR18: General Graphics Command Register 2

Read/Write Address: 3C5h, Index: 18h
 Power-on Default: 00h

This register specifies command control for aperture select, graphics modes select, 32/64 memory data path select and linear addressing mode enable.

7	6	5	4	3	2	1	0
SCLK	ECLK	AS	GRAPHICS MODE		MDP	ERH	LMM

- Bit 7** Select ~CLKRUN or ACTIVITY (SCLK)
 0 = Select ~CLKRUN as input for Pin 161
 1 = Select ACITIVITY as output for Pin 161
- Bit 6** Enable ~CLKRUN Function (ECLK)
 0 = disable
 1 = enable
- Bit 5** Aperture Select. This bit is only valid in linear memory mode (bit 0 = 1) (AS)
 0 = Select dual aperture. Allow 0A0000h-0AFFFFh and linear aperture to coexist.
 1 = Select single aperture. Only linear aperture can be used.
- Bit 4:3** Graphics Modes Select for Memory Access
 00 = Standard VGA mode. The memory access only uses the lower 32-bit of the 64-bit internal memory bus. The memory address wraps after 256 KB.
 01 = VESA Super VGA 16 color (4-bit) mode. The memory access only uses the low 32-bit of the 64-bit internal memory bus. The memory address does not wrap after 256 KB.
 1x = Extended packed pixel graphics modes (8/16/24/32-bit). The memory access always use the internal 64-bit memory bus.
- Bit 2** 32/64 memory data path select. This bit is only valid in VGA or VESA Super VGA 16 color modes (bit 4 of this register = 0) (MDP)
 0 = CPU access VGA memory. All host memory access goes through VGA aperture: 0A0000h - 0BFFFFh (controlled by 3CFh index 6 Bit [3:2]). The memory access only uses the low 32-bit of the 64-bit memory bus.
 1 = CPU access graphics memory. All host memory access does not goes through VGA aperture. This bit is used to allow 64-bit memory access even in VGA or super VGA 16 color modes.
 For example, when programming pop-up icon in VGA mode or VESA super VGA 16 color mode, one must set bit 2 = 1 and bit 4 = 0 of this register, in order to access full range of the display memory.
- Bit 1** Enable Repeat Hardware Rotation BLT function (ERH)
 0 = disable
 1 = enable

Bit 0 Linear Memory Mode Enable (LMM)
 0 = disable. Nonlinear addressing (banking) mode is selected, and MCR61 register will be used for memory bank select. Memory will be accessed according to 3CF index 6 Bit [3:2]:
3CF.6 Bit [3:2]Memory Range
 00 0A0000-0BFFFF
 01 0A0000-0AFFFF
 10 0B0000-0B7000
 11 0B8000-0BFFFF
 1 = enable. Linear memory mode is selected, and memory will be accessed according to the PCI base address register.

SCR19: Interrupt Enable and Mask I

Read/Write Address: 3C5h, Index: 19h
 Power-on Default: 00h

This register specifies interrupt enables and interrupt masks for PCI master, Zoom Video Port, and Drawing Engine. Each interrupt mask will block out its particular interrupt when the interrupt mask is enabled. When the interrupt mask is disabled, the corresponding interrupt will be generated when its particular interrupt is enabled.

7	6	5	4	3	2	1	0
IEVGA	R	IEZVP	IEDE	RESERVED		IMZVP	IMDE

Bit 7 Interrupt Enable for VGA (IEVGA)

Bit 6 Reserved (R)

Bit 5 Interrupt Enable for Zoom Video Port (IEZVP)
 0 = Disable
 1 = Enable

Bit 4 Interrupt Enable for 2D/3D Drawing Engine (IEDE)
 0 = Disable
 1 = Enable

Bit 3:2 Reserved

Bit 1 Interrupt Mask for Zoom Video Port (IMZVP)
 0 = Disable
 1 = Enable

Bit 0 Interrupt Mask for 2D/3D Drawing Engine (IMDE)
 0 = Disable
 1 = Enable

SCR1A: Interrupt Status

Read Only Address: 3C5h, Index: 1Ah

Power-on Default: Undefined

This register specifies Interrupt Status of Drawing Engine, Video Port, PCI Master, and VGA. The interrupt enable and mask bits for these interrupts are located in SCR19 register, with the exception of VGA's enable and mask bits which reside within the VGA block.

7	6	5	4	3	2	1	0
ICMD	IDCT	3D TE	VGA	HMCIS	R	ZVP	DEI

- Bit 7** ICMD Interrupt Status (ICMD)
0 = No interrupt
1 = ICMD interrupt is detected
- Bit 6** IDCT Interrupt Status (IDCT)
- Bit 5** 3D Texture Engine Interrupt Status (3D TE)
0 = No interrupt
1 = 3D Texture Engine interrupt detected
- Bit 4** VGA Interrupt Status. VGA's interrupt enable and mask bits are in the VGA block. (VGA)
0 = No interrupt
1 = VGA Interrupt is detected
- Bit 3** Host Memory Control Interrupt Status (HMCIS)
0 = No interrupt
1 = Master Control
- Bit 2** Reserved
- Bit 1** Zoom Video Port Interrupt Status (ZVP)
0 = No interrupt
1 = Zoom Video Port Interrupt is detected
- Bit 0** 2D/3D Drawing Engine Interrupt Status (DEI)
0 = No interrupt
1 = Drawing Engine Interrupt is detected

SCR1B: Interrupt Status Enable and Mask II

Read Only: Address: 3C5h, Index: 1Bh

Power-on Default: 00h

7	6	5	4	3	2	1	0
ICMDIE	IDCTIE	TEXTURE	HMCIE	ICMDIM	IDCTIM	TEXTURE	HMIMM

- Bit 7** ICMD Interrupt Enable (ICMDIE)
0 = Disable ICMD interrupt (hardware interrupt to system)
1 = Enable ICMD interrupt (hardware interrupt to system)
- Bit 6** IDCT Interrupt Enable (IDCTIE)
0 = Disable IDCT interrupt (hardware interrupt to system)
1 = Enable IDCT interrupt (hardware interrupt to system)
- Bit 5** Text 3D Interrupt Enable (TEXTURE)
0 = Disable Text 3D interrupt (hardware interrupt to system)
1 = Enable Text 3D interrupt (hardware interrupt to system)
- Bit 4** Host Master Control Interrupt Enable (HMCIE)
0 = Disable Host Master interrupt (hardware interrupt to system)
1 = Enable Host Master interrupt (hardware interrupt to system)
- Bit 3** ICMD Interrupt Mask (ICMDIM)
0 = Allow ICMD interrupt signal to be latched into interrupt register
1 = Will not allow ICMD interrupt signal to be into interrupt register
- Bit 2** IDCT Interrupt Mask (IDCTIM)
0 = Allow IDCT interrupt signal to be latched into interrupt register
1 = Will not allow IDCT interrupt signal to be into interrupt register
- Bit 1** Texture (TEXTURE)
0 = Allow Texture interrupt signal to be latched into interrupt register
1 = Will not allow Texture interrupt signal to be into interrupt register
- Bit 0** Host Control Interrupt Mask Master (HCIMM)
0 = Allow Host Control interrupt signal to be latched into interrupt register
1 = Will not allow Host Control interrupt signal to be into interrupt register

SCR1C: Interrupt Status

Read Only: Address: 3C5h, Index: 1Ch
Power-on Default: 00h

7	6	5	4	3	2	1	0
RESERVED				Usr3	Usr2	RESERVED	

- Bit 7:4** Reserved
- Bit 3** Usr3 Interrupt Status
- Bit 2** Usr2 Interrupt Status
- Bit 1:0** Reserved

Bit 0 Usr0 Interrupt Status

SCR1F: Interrupt Mask and Hardware Interrupt Enable

Read Only: Address: 3C5h, Index: 1Fh

Power-on Default: 00h

7	6	5	4	3	2	1	0
USR3	USR2	RESERVED		USR3IM	USR2IM	RESERVED	

Bit 7 Usr3 to enable system hardware interrupt
 0 = Disable USR3 Pin as interrupt (default)
 1 = Enable USR3 Pin as interrupt input

Bit 6 Usr2 to enable system hardware interrupt
 0 = Disable USR3 Pin as interrupt (default)
 1 = Enable USR3 Pin as interrupt input

Bit 5:4 Reserved

Bit 3 Usr3 Interrupt Mask

Bit 2 Usr2 Interrupt Mask

Bit 1:0 Reserved

SCR24: Reserved

Read Only: Address: 3C5h, Index: 24h

Power-on Default: 00h

7	6	5	4	3	2	1	0
RESERVED		RESERVED		RESERVED			

Bit 5:4 11 = Default

Power Down Control Registers

The power down control registers are controlled by system clock only. The power down control registers can still be read or written by CPU even when internal PLL is off.

PDR20: Power Down Control for Memory, Flat Panel, PLL, and Video Port

Read/Write Address: 3C5h, Index: 20h

Power-on Default: 04h

This register defines the different power down control for Memory, Flat Panel Interface, PLL, and Video Port. This register can still be read or written by CPU even when PLL is off.

7	6	5	4	3	2	1	0
SPDM	SMR	SICLK		LVDS	VPO	FPI	DMI

- Bit 7** Select Power Down Mode. External "~PDOWN" pin needs to be pulled "Low" to enable the selected power down mode. For more details on power down modes, please refer to the power down management chapter of this data book. (SPDM)
0 = Standby mode
1 = Sleep mode
- Bit 6** Select Memory Refresh Type During Sleep Mode (Bit 7 of this register = 1). (SMR)
0 = Auto Refresh
1 = Self Refresh
- Bit 5:4** Select internal VCLK and MCLK frequencies to control DRAM refresh during standby or sleep mode (CCR69 bit 3 = 1). This register setting will be ignored when the chip is in operation mode. (SICLK)
00 = No change.
01 = Both VCLK and MCLK are divided by 4 (standby and sleep mode)
10 = Both VCLK and MCLK are divided by 8 (standby and sleep mode)
11 = Both VCLK and MCLK are divided by 16 (sleep mode only)
- Bit 3** Tri-state LVDSCLK output pin. When ~EXCKEN = 0, Pin 159 (MCKIN) becomes an input pin. When ~EXCKEN = 1, Pin 159 (LVDSCLK) becomes an output pin. This register is only valid when ~EXCKEN = 1. This bit is used to test the silicon. (LVDS)
0 = Enable LVDSCLK output pin
1 = Tri-state LVDSCLK output pin
- Bit 2** Tri-state Video Port Output. When this bit = 0, 20-bit outputs (R[7:2], G[7:2], B[7:2], BLANK, and PCLK) will be driven out. When Video Capture is enabled (CPR00 [0] = 1), video port output will be tri-stated automatically, except for BLANK/TVCLK output pin. This bit is used to test the silicon. (VPO)
0 = Enable output pins
1 = Tri-state output pins (default)
- Bit 1** Tri-state Flat Panel Interface Output Pins. This bit is used to test the silicon (FPI)
0 = Enable output pins
1 = Tri-state output pins
- Bit 0** Tri-state Display Memory Interface output pins. This bit can also be used to isolate Lynx3DM from display memory. All display memory interface pins: control signals, output clock, data bus and address bus are tri-stated. This bit is used to test the silicon. (DMI)
0 = Enable display memory interface output pins
1 = Tri-state display memory interface output pins

PDR21: Functional Blocks Disable Control

Read/Write Address: 3C5h, Index: 21h

Power-on Default: B0h

This register is designed to achieve optimum power saving in operation mode. Special clock drivers are built-in to control major functional blocks independently. This power saving feature will not affect the graphics and video performance, or LCD display quality. This register could be read or written by CPU even when PLL is off.

7	6	5	4	3	2	1	0
MHZ	PLLS	FBWO	FBRO	CPR	ZVP	DE	VP

- Bit 7** Disable 200 MHz DAC (MHZ)
0 = Enable DAC
1 = Disable DAC
- Bit 6** Disable PLLs (PLLS). This is only effective at power down mode.
0 = Enable PLLs
1 = Disable PLLs
- Bit 5** Disable LCD Frame Buffer Write Operation. This bit is used to shut-down the (FBWO) 64 x 8 LCD write FIFO and remove the display memory bus request for LCD frame buffer write from arbitration control.
This bit needs to be set to "1" in Dual View Mode -- displaying different graphics data on CRT (or TV) and LCD.
This bit should be set to "1" when LCD display is not enabled or when TFT is selected in standard refresh mode in order to obtain optimum power saving.
0 = Enable LCD frame buffer write
1 = Disable LCD frame buffer write
- Bit 4** Disable LCD Frame Buffer Read Operation and DSTN Dithering Engine. This bit is used to shut-down the 64 x 8 LCD read FIFO1 and LCD read FIFO2, turn off DSTN dithering engine and remove the display memory bus request from LCD Read FIFO1 and LCD read FIFO2. (FBRO)
This bit should be set to "1" when LCD display is not enabled, or when TFT is selected in standard refresh mode.
0 = Enable LCD frame buffer read and DSTN dithering engine
1 = Disable LCD frame buffer read and DSTN dithering engine
- Bit 3** Disable 256 x 18 Color Palette RAM. Color Palette RAM will be automatically disabled by hardware in standby mode or sleep mode. (CPR)
0 = Enable Color Palette RAM
1 = Disable Color Palette RAM
- Bit 2** Disable Zoom Video Port. This bit is used when there is no external video source which is connected to the Lynx3DM. The Lynx3DM will block input data from external video port, turn off the clock driver of ZV Port, and remove the ZV Port display memory bus request from memory controller. (ZVP)
0 = Enable Zoom Video Port
1 = Disable Zoom Video Port

- Bit 1** Disable 2D/3D Drawing Engine. This bit is used to turn-off the 2D/3D drawing engine block. For optimum power saving, this bit should be set to "1" in standard VGA mode since 2D/3D drawing engine is not in use. (DE)
0 = Enable 2D/3D drawing engine
1 = Disable 2D/3D drawing engine
- Bit 0** Disable Video Processor. This bit is used to turn-off the video processor block which includes graphics FIFO, V0FIFO, V1FIFO, horizontal/vertical color interpolation, YUV-to-RGB conversion, TV flicker reduction, HW pop-up icon, and related control logic. For optimum power saving, This bit could be set to "1" in standard VGA mode since video processor is not in use. (VP)
0 = Enable video processor
1 = Disable video processor

PDR22: LCD Panel Control Select

Read/Write Address: 3C5h, Index: 22h
Power-on Default: x0h

This register specifies the flat panel control and data: FPEN, VBIASEN, FPVDDEN. This register is not valid when panel S/W power ON/OFF sequence is selected during display switching - FPR34 bit 7 = 0. For panel power ON/OFF sequence, please refer to the flat panel interface chapter of this data book.

7	6	5	4	3	2	1	0
RESERVED		DPMS CONTROL		FPEN	VOP	FP	FOP

Bit 7:6 Reserved

Bit 5:4 DPMS Control

	DPMS State	VSYNC	HSYNC
00 =	Normal	Pulses	Pulses
01 =	Standby	Pulses	No Pulse
10 =	Suspend	No Pulse	Pulses
11 =	Off	No Pulse	No Pulse

Bit 3 Control FPEN output pin. This function is disabled when LCD H/W auto-power ON/OFF sequence is enabled (FPR34 bit 7 = 1). This pin can also be used to control LCD back light (VBKLGTT) at the same time. FPEN is part of the VESA FDPI-1B specification. (FPEN)
0 = Driven low
1 = Driven high

Bit 2 Control VBIASEN output pin. This function is disabled when LCD H/W auto-power ON/OFF sequence is enabled (FPR34 bit 7 = 1). (VOP)
0 = Driven low
1 = Driven high

Bit 1 Disable Flat Panel control signals and data lines. All Control signals and data lines from output pins will be forced to logic "Low". (FP)

- 0 = Enable Flat Panel control signals and data
- 1 = Disable Flat Panel control signals and data

Bit 0 Control FPVDDEN output pin. This function is disabled when LCD H/W auto-power ON/OFF sequence is enabled (FPR34 bit 7 = 1). (FOP)

- 0 = Driven low
- 1 = Driven high

PDR23: Activity Detection Control Register

Read/Write Address: 3C5h, Index: 23h
Power-on Default: 00h

The activity detection function is used to monitor I/O write and memory write activities. System designer can select a fixed time period by programming bit [2:0] of this register. An internal timer will count the idle period of memory write or I/O write operation. If the idle period is equal or greater than the selected value, a "Low-High" or "High-Low" on the ACTIVITY output signal will generate to the system. Any Memory write or I/O write operation will reset the ACTIVITY output signal and the internal counter. Please note that the internal counter will not start unless video capture is disabled (CPR00 bit 0 = 0). The activity detection can also be used to enable internal auto-standby mode.

7	6	5	4	3	2	1	0
ECAD	EIAS	SA	SELECT I/O		INTERNAL TIMER SELECT		

- Bit 7** Enable chip activity detection (ECAD)
- 0 = Disable
 - 1 = Enable
- Bit 6** Enable internal auto-standby mode. This bit has no effect if chip activity detection is disabled (PDR23 bit 7 = 0). This bit is used to enable internal auto-standby mode through activity detection function. Before enabling this function, the internal timer bit [2:0] of this register needs to be programmed first. (EIAS)
- 0 = Disable
 - 1 = Enable
- Bit 5** Select active "LOW" or "HIGH" signal for the ACTIVITY output (SA)
- 0 = Select active "LOW"
 - 1 = Select active "HIGH"
- Bit 4:3** Select I/O Write Activity Detection or Host Memory Write Activity Detection
- 00 = No detection
 - 01 = Enable Host Memory Write detect
 - 10 = Enable I/O Write detect
 - 11 = Enable both I/O Write and Host Memory Write detect
- Bit 2:0** Internal Timer Select
- 000 = Select 0 minute
 - 001 = Select 1 minute (4K vertical frames period in standard setting)
 - 010 = Select 2 minutes
 -
 - 110 = Select 32 minutes

111 = Select 64 minutes (256K vertical frames period)

PDR24: Power Down Register SelectRead/Write Address: 3C5h, Index: 24h
Power-on Default: 00h

7	6	5	4	3	2	1	0
RESERVED							(PDMS)

Bit 7:1 Reserved

Bit 0 Power Down Mode Select (PDMS)
 0 = VESA Compliance power down mode
 1 = ACPI power down Spec 1.0 compliance

Flat Panel Registers**FPR30: Flat Panel Type Select**Read/Write Address: 3C5h, Index: 30h
Power-on Default: This is a power-on configurable register (by RESET)

This register specifies different types of flat panel.

7	6	5	4	3	2	1	0
DSTN	COLOR TFT			LCD DISPLAY		TFT	LCD

Bit 7 Color DSTN interface type select. This bit is power-on configurable by MD15. (DSTN)
 0 = 16-bit interface
 1 = 24-bit interface

Bit 6:4 Color TFT interface type select. This is a power-on configurable bit by MD [14:12]. For detailed interconnection for different type of LCD panels, please refer to the Flat Panel Interface Chapter of this data book.
 000 = 9-bit, 3-bit per R, G, B
 001 = 12-bit, 4-bit per R, G, B
 010 = 18-bit, 6-bit per R, G, B
 011 = 24-bit, 8-bit per R, G, B
 100 = 12+12-bit, or 24-bit (two pixels/clock)
 101 = analog TFT interface
 110 = 18+18-bit, or 36-bit (two pixels/clock)
 111 = 24+24-bit (two pixels/clock)

Bit 3:2 LCD display size select for DSTN and TFT LCD. This is a power-on configurable bit by MD [11:10].
 00 = 640 x 480
 01 = 800 x 600

10 = 1024 x 768

11 = 1280 x 1024 (reserved for color TFT only)

Bit 1 TFT FPSCLK Clock Phase Select. To adjust TFT flat panel data timing, one may wish to change the TFT FPSCLK phase by inverting the TFT FPSCLK. This register is only valid for TFT panel in single pixel/clock mode and 2 pixels/clock mode. (TFT)

This is a power-on configurable bit by MD9.

0 = Normal

1 = Inverted clock

Bit 0 Color LCD type select. This is a power-on configurable bit by MD8. (LCD)

0 = color TFT

1 = color DSTN

FPR31: Virtual Refresh and Auto Shut Down Control

Read/Write Address: 3C5h, Index: 31h

Power-on Default: 00h

This register defines the control for display select, Virtual Refresh mode enable and auto shut-down.

7	6	5	4	3	2	1	0
VRE	VRES	SELECT AUTO S/D		EASD	DISPLAY SELECT		

Bit 7 Virtual Refresh Enable. This bit is independent of FPR31 bit [2:0]. (VRE)

0 = Disable

1 = Enable

Bit 6 Virtual Refresh Encode Select (VRES)

0 = Select 8-bit per pixel encode, RGB = 3:3:2

1 = Select 16-bit per pixel encode, RGB = 5:6:5

Bit 5:4 Select Auto Shut-Down Period. Define a period to start auto shut-down of display memory screen refresh cycle and LCD frame buffer write cycle. Auto shut-down mode can only be used when the display is in LCD mode only and Virtual Refresh is enabled. This function is only valid when auto shut-down of memory screen refresh and LCD frame buffer write cycles are enabled (bit 3 of this register = 1).

00 = 8 frames

01 = 16 frames

10 = 32 frames

11 = 64 frames

Bit 3 Enable auto shut-down of display memory screen refresh cycle and LCD frame buffer write cycle in Virtual Refresh mode. This bit is only valid when Virtual Refresh mode is enabled (FPR31 bit 7 = "1"). If the display memory write operation is idle for more than the selected period specified by FPR31 bit [5:4], the display memory screen refresh cycle and LCD frame buffer write cycle will be automatically shut-down when auto shut-down is enabled. The graphics FIFO and video FIFO are also shut-down. Any Host memory write operation to Lynx3DM will turn on the display memory screen refresh and LCD frame buffer write cycle at the end of a vertical sync signal. (EASD)

0 = Disable auto shut-down

1 = Enable auto shut-down

- Bit 2:0** Display Select. (Note: TV and CRT can not be enabled at the same time.)
- 000 = Disable all displays (default value)
 - 001 = Enable LCD display
 - 010 = Enable CRT display
 - 011 = Enable both CRT and LCD display
 - 100 = Enable TV display
 - 101 = Enable both TV and LCD display
 - others = Reserved

FPR32: Dithering Engine Select, Polarity, and Expansion Control

Read/Write Address: 3C5h, Index: 32h

Power-on Default: 00h

This register defines the TFT and DSTN dithering engines select, LCD signal polarities, and screen auto-centering or vertical expansion select.

7	6	5	4	3	2	1	0
TFT DITHERING	STN	LCDV	LCDH	ACE	VLEE	HPEE	

- Bit 7:6** TFT Dithering Engine Select
- 00 = No dithering
 - 01 = 4-gray level dithering patterns (for 9-bit, 12-bit, and 18-bit TFT only)
 - 10 = 8-gray level dithering patterns (for 9-bit and 12-bit TFT only)
 - 11 = Reserved

FPR30 [6:4]				
	= 000	= 001 or 100	= 010 or 110	= 011
Bit [7:6]	9-bit	12-bit	18-bit	24-bit
00	512 colors	4K colors	256K colors	16M colors
01	24,389 colors	226,981 colors	16M colors	16M colors
10	185,193 colors	1,771,561 colors	16M colors	16M colors

- Bit 5** STN Dithering Engine Select (STN)
- 0 = Select 16 gray levels for each R, G, and B
 - 1 = Select 32 gray levels for each R, G, and B

- Bit 4** LCD VSYNC/FP Polarity Select (LCDV)
- 0 = Select active "LOW"
 - 1 = Select active "HIGH"

- Bit 3** LCD HSYNC/LP polarity Select (LCDH)
- 0 = Select active "LOW"
 - 1 = Select active "HIGH"

- Bit 2** Auto Centering Enable. This register is used to control screen centering for VGA modes. (ACE)
0 = Disable
1 = Enable. This bit needs to be set to "1" and CRT shadow registers need to be reprogrammed to allow screen centering.
- Bit 1** Vertical Line Expansion Enable for VGA modes (VLEE)
0 = Disable
1 = Enable
- Bit 0** Horizontal Pixel Expansion Enable for VGA modes (HPEE)
0 = Disable
1 = Enable. Character clock is forced to 10-dot timing.

FPR33: Panel Power Sequence and LCD Character/Cursor Blink Control

Read/Write Address: 3C5h, Index: 33h
Power-on Default: 05h

This register defines the control for LCD power ON/OFF sequence timing, lock VGACRT horizontal and vertical display enable, and blinking rate for LCD character/cursor.

7	6	5	4	3	2	1	0
RESERVED		VDE	R	PANEL ON/OFF		SELECT LCD	

- Bit 7:6** Reserved
- Bit 5** Lock VGA CRT Vertical and Horizontal Display Enable registers used in Virtual Refresh mode (FPR31 bit 7 = 1) to lock the control signals to LCD BKEND. When this bit is set to 1, it will lock the following registers: CRT01 (3?5h, index1) [Horizontal Display Enable], CRT07 (3?5h, index 07) bit 6 [Vertical Display Enable bit 9] and bit 1[Vertical Display Enable bit 8], CRT12 (3?5h, index12) [Vertical Display Enable]. (VDE)
This register is also used to lock Shadow VGA CRT Horizontal Display Enable and Vertical Display Enable Registers.
0 = unlock (default)
1 = lock
- Bit 4** Reserved (R)
- Bit 3:2** Panel ON/OFF timing select. These two bits are used to control the time period from FPEN to VBIASEN, from VBIASEN to LCD control signals, and from LCD control signals to FPVDDEN. These two bits are only valid when LCD H/W auto-power ON/OFF sequence is selected (FPR34 bit 7 =1).
00 = 1 vertical frame
01 = 2 vertical frames
10 = 4 vertical frames
11 = 8 vertical frames
- Bit 1:0** Select LCD character/cursor blink rate

Bit [1:0]	Cursor	Character
00	16 frames	32 frames
01	32 frames	64 frames
10	64 frames	128 frames

FPR34: LCD Panel ON/OFF Sequence Select and DSTN LCD Control

Read/Write Address: 3C5h, Index: 34h
Power-on Default: 80h

This register defines LCD panel ON/OFF sequence select during display switching and color DSTN panel control, such as: LP pulse width, additional line pulse in odd and even frame.

7	6	5	4	3	2	1	0
SHS	SLP	SELPO		SELECT EXTRA LP EVEN FRAME			

Bit 7 Select Hardware or Software LCD auto-power ON/OFF sequence during display switching in operation or power down modes. This bit can be used to select two different ways to turn ON/OFF LCD panel. For special programming sequences, please refer to the Power Down Management chapter of this data book. (SHS)

0 = Select software LCD power sequencing
1 = Select hardware LCD power sequencing

Bit 6 Select LP (DSTN) Pulse Width in Pixel Clocks (SLP)

0 = 16 pixel clocks
1 = 32 pixel clocks

Bit 5:4 Select Extra LP in Odd Frame for DSTN LCD in Standard Refresh Mode (SELPO)

00 = 0 extra line pulses
01 = 1 extra line pulses
10 = 2 extra line pulses
11 = 3 extra line pulses

Bit 3:0 Select Extra LP in Even Frame for DSTN LCD in Standard Refresh Mode, or Extra LP in Every Frame for DSTN LCD in Virtual Refresh Mode.

0000 = 0 extra line pulses
0001 = 1 extra line pulses
0010 = 2 extra line pulses
.....
1111 = 15 extra line pulses

FPR3E: DSTN LCD Panel Height- High

Read/Write Address: 3C5h, Index: 3Eh
Power-on Default: 00h

This register defines bit 9 and bit 8 of DSTN LCD panel height register. This 10-bit register needs to be programmed as "DSTN LCD panel height + 2". This 10-bit register also has to be an even number. For example, DSTN LCD panel height register equals to "12Ch" for a 800x600 DSTN.

7	6	5	4	3	2	1	0
DES	RESERVED				LP	DSTN LCD PANEL	

Bit 7 M-Signal or Display Enable Select (DES)
0 = Select Display Enable as output for Pin 81
1 = Select M-Signal as output for Pin 81

Bit 6:3 Reserved

Bit 2 Free running LP enable for OSTN (LP)
0 = Disable
1 = Enable

Bit 1:0 Bit 9 and bit 8 of the 10-bit DSTN LCD Panel Height Register.

FPR3F: DSTN LCD Panel Height- Low

Read/Write Address: 3C5h, Index: 3Fh
Power-on Default: 00h

7	6	5	4	3	2	1	0
BIT [7:0] OF THE 10-BIT DSTN LCD PANEL HEIGHT REGISTER							

This register defines lower 8-bit of DSTN LCD panel height register. This 10-bit register needs to be programmed as "DSTN LCD panel height ÷ 2". This 10-bit register also has to be an even number. For example, DSTN LCD panel height register equals to "180h" for a 1024x768 DSTN LCD.

Bit 7:0 Bit [7:0] of the 10-bit DSTN LCD Panel Height Register.

FPR40: Read FIFO1 Start Address Low for LCD Frame Buffer

Read/Write Address: 3C5h, Index: 40h
Power-on Default: Undefined

This register defines the lower 8-bit of the read FIFO1 start address for LCD frame buffer. This Read FIFO1 start address is used for DSTN LCD in standard refresh mode or TFT LCD in Virtual Refresh mode. When DSTN LCD is selected and in Virtual Refresh mode, this register defines the lower 8-bit of the read FIFO1 start address for upper panel of the DSTN LCD.

7	6	5	4	3	2	1	0
BIT [7:0] OF DISPLAY MEMORY READ FIFO1							

Bit 7:0 Select bit [7:0] of display memory read FIFO1 address bus for the LCD frame buffer of DSTN LCD in standard refresh mode or for TFT LCD in Virtual Refresh mode. When Virtual Refresh is enabled (FPR31 bit 7 = 1) and when DSTN LCD is selected (FPR30 [1:0] = 01b), this register selects bit [7:0] of the display memory read FIFO1 address for the upper panel of DSTN LCD.

FPR41: Read FIFO1 Start Address High for LCD Frame Buffer

Read/Write Address: 3C5h, Index: 41h
Power-on Default: Undefined

This register defines the higher 8-bit of the read FIFO1 start address for LCD frame buffer. This Read FIFO1 start address is used for DSTN LCD in standard refresh mode or TFT LCD in Virtual Refresh mode. When DSTN LCD is selected and in Virtual Refresh mode, this register defines the higher 8-bit of the read FIFO1 start address for upper panel of the DSTN LCD.

7	6	5	4	3	2	1	0
BIT [15:8] OF DISPLAY MEMROY READ FIFO1							

Bit 7:0 Select bit [15:8] of display memory read FIFO1 address bus for the LCD frame buffer of DSTN LCD in standard refresh mode or for TFT LCD in Virtual Refresh mode. When Virtual Refresh is enabled (FPR31 bit 7 = 1) and when DSTN LCD is selected (FPR30 [1:0] = 01b), this register selects bit [15:8] of the display memory read FIFO1 address for the upper panel of DSTN LCD.

FPR42: Read FIFO2 Start Address Low for LCD Frame Buffer

Read/Write Address: 3C5h, Index: 42h
Power-on Default: Undefined

This register defines the lower 8-bit of the read FIFO2 start address for LCD frame buffer. This register is only valid when DSTN LCD is selected (FPR30 [1:0] = 01b) and Virtual Refresh is enabled (FPR31 bit 7 = 1).

7	6	5	4	3	2	1	0
BIT [7:0] OF DISPLAY MEMORY READ FIFO2							

Bit 7:0 Select bit [7:0] of display memory read FIFO2 address bus for lower panel of DSTN LCD.

FPR43: Read FIFO2 Start Address High for LCD Frame Buffer

Read/Write Address: 3C5h, Index: 43h
Power-on Default: Undefined

This register defines the higher 8-bit of the read FIFO2 start address for LCD frame buffer. This register is valid only when DSTN LCD is selected (FPR30 [1:0] = 01b) and Virtual Refresh is enabled (FPR31 bit 7 = 1).

7	6	5	4	3	2	1	0
BIT [15:8] OF DISPLAY MEMORY READ FIFO2							

Bit 7:0 Select bit [15:8] of display memory read FIFO2 address bus for lower panel of DSTN LCD.

FPR44: Read FIFO1 Offset Value of LCD Frame Buffer

Read/Write Address: 3C5h, Index: 44h
Power-on Default: Undefined

This register defines the read FIFO1 offset value of LCD Frame buffer. This offset value is used to calculate the read start address of the next line of LCD Frame buffer from the current line. The offset register is a 10-bit register. Bit [3:2] of Read Offset Value Register are in FPR4C register.

7	6	5	4	3	2	1	0
BIT [7:0] OF READ FIFO1							

Bit 7:0 Bit [7:0] of read FIFO1 offset value for LCD frame buffer. This offset value is a direct mapping from bit [10:3] of display memory read address bus.

FPR45: Read FIFO1 Address Offset for LCD Frame Buffer Overflow

Read/Write Address: 3C5h, Index: 45h
Power-on Default: Undefined

This register defines the MSB of the read FIFO1 start address. In additional, this register specifies the MSB of the LCD frame buffer read offset value.

7	6	5	4	3	2	1	0
DISPLAY MEM READ FIFO1				DISPLAY MEM READ FIFO2			

Bit 7:4 Bit [19:16] of display memory read FIFO1 address bus. The lower [15:0] of display memory read FIFO1 address is located in FPR41 and FPR40 registers.

When TFT LCD is in Virtual Refresh mode, or DSTN LCD is in standard refresh mode, this register specifies bit [18:16] of display memory read address. This register is used for upper panel of DSTN LCD when Virtual Refresh is enabled (FPR 31 bit 7 = 1) and DSTN LCD (FPR30 [1:0] = 01b) is selected.

Bit 3:0 Bit [19:16] of display memory read FIFO2 address bus for lower panel of DSTN LCD. The lower [15:0] of display memory read FIFO1 address is located in FPR43 and FPR42 registers. This register is valid only when DSTN LCD is selected (FPR30 [1:0] = 01b) and Virtual Refresh is enabled (FPR31 bit 7 = 1).

FPR46: Write Start Address Low of LCD Frame Buffer

Read/Write Address: 3C5h, Index: 46h
Power-on Default: Undefined

This register defines the lower 8-bit of the start address for LCD Write Frame Buffer.

7	6	5	4	3	2	1	0
BIT [7:0] OF START ADDRESS LCD							

Bit 7:0 Bit [7:0] of start address for LCD write frame buffer. This register is a direct mapping from bit [10:3] of display memory write address bus.

FPR47: Write Start Address High of LCD Frame Buffer

Read/Write Address: 3C5h, Index: 47h
Power-on Default: Undefined

This register defines the high byte start address of LCD Write Frame Buffer.

7	6	5	4	3	2	1	0
BIT [7:0] OF START ADDRESS LCD WRITE FRAME BUFFER							

Bit 7:0 Bit [15:8] of start address for LCD write frame buffer. This register is a direct mapping from bit [18:11] of display memory write address bus.

FPR48: Write Offset Value of LCD Frame Buffer

Read/Write Address: 3C5h, Index: 48h
Power-on Default: Undefined

This register defines the offset value of LCD Write Frame Buffer. This offset value is used to calculate the start address of the next line of LCD Write Frame Buffer from the current line. The offset register is a 10-bit register. Bit [9:8] of the write offset value is in FPR49 register.

7	6	5	4	3	2	1	0
BIT [7:0] OF OFFSET VALUE LCD WRITE FRAME BUFFER							

Bit 7:0 Bit [7:0] of offset value for LCD write frame buffer. This offset value is a direct mapping from bit [10:3] of display memory write address bus.

FPR49: LCD Frame Buffer Write Overflow

Read/Write Address: 3C5h, Index: 49h
Power-on Default: Undefined

This register specifies the MSB of the LCD frame buffer write offset address. The lower 8-bit of the LCD frame buffer write offset address is in FPR48.

7	6	5	4	3	2	1	0
START ADDRESS LCD						OVR	

Bit 7:2 Bit [21:16] of start address for LCD Write Frame Buffer. This register is a direct mapping from bit [21:19] of display memory write address bus.

Bit 1:0 Bit [9:8] of offset value register of LCD Write Frame Buffer. These two bits are mapped to bit 12 and 11 of display memory write address bus. The lower 8 bits are in FPR48. (OVR)

FPR4A: LCD Read and Write FIFOs Request Level Control

Read/Write Address: 3C5h, Index: 4Ah
Power-on Default: 44h

This register controls the LCD Read and Write FIFOs Request Level. These bits can be used to maximize the available memory bandwidth.

7	6	5	4	3	2	1	0
LCD READ FIFO2		LCD READ FIFO1		RESERVED		LCD WRITE FIFO	

Bit 7:6 LCD Read FIFO2 Request Level. When the LCD Read FIFO2 empty level reaches the level specified by this register, a LCD Read FIFO2 Request will be generated.

- 00 = RFIFO2 has 4 or more entries empty
- 01 = RFIFO2 has 8 or more entries empty
- 1x = RFIFO2 has 12 or more entries empty

Bit 5:4 LCD Read FIFO1 Request Level. When the LCD Read FIFO1 empty level reaches the level specified by this register, a LCD Read FIFO1 Request will be generated.

- 00 = RFIFO1 has 4 or more entries empty
- 01 = RFIFO1 has 8 or more entries empty
- 1x = RFIFO1 has 12 or more entries empty

Bit 3:2 Reserved

Bit 1:0 LCD Write FIFO Request Level. When the LCD Write FIFO filled level reaches the level specified by this register, a LCD Write Request will be generated.

- 00 = WFIFO has 4 or more entries filled
- 01 = WFIFO has 8 or more entries filled
- 1x = WFIFO has 12 or more entries filled

FPR4B: Read FIFO2 Offset Value of LCD Frame Buffer

Read/Write Address: 3C5h, Index: 4Bh
Power-on Default: Undefined

This register defines the read FIFO2 offset value of LCD Frame buffer. This offset value is used to calculate the read start address of the next line of LCD Frame buffer from the current line. The offset register is a 10-bit register.

7	6	5	4	3	2	1	0
BIT [7:0] OF READ FIFO2 OFFSET VALUE							

Bit 7:0 Bit [7:0] of read FIFO2 offset value for LCD frame buffer. This offset value is a direct mapping from bit [10:3] of display memory read address bus. The upper two bits are in FPR4C register.

FPR4C: Read FIFO Offset Value of LCD Frame Buffer Overflow

Read/Write Address: 3C5h, Index: 4Ch
Power-on Default: Undefined

This register defines the read FIFO offset value of LCD Frame buffer. This offset value is used to calculate the read start address of the next line of LCD Frame buffer from the current line.

7	6	5	4	3	2	1	0
READ FIFO2		RESERVED		FPR44		RESERVED	

Bit 7:6 Bit [9:8] of Read FIFO2 offset value register of LCD Frame buffer. These two bits are mapped to bit [12:11] of display memory address bus. The lower 8 bits are in FPR4B register.

Bit 5:4 Reserved

Bit 3:2 Bit [9:8] of Read FIFO 1 offset Lower 8-bit are in FPR44 (FPR44)

Bit 1:0 Reserved

FPR4D: MSB Read FIFO Address

Read/Write Address: 3C5h, Index: 4Dh
Power-on Default: Undefined

7	6	5	4	3	2	1	0
RESERVED		MSB READ FIFO2		RESERVED		MSB READ FIFO1	

Bit 7:6 Reserved

Bit 5:4 MSB of Read FIFO2 Address

Bit 3:2 Reserved

Bit 1:0 MSB of Read FIFO1 Address

LCD2: LCD2 Control Register

Read/Write Address: 3C5h, Index: D2h
Power-on Default: Undefined

7	6	5	4	3	2	1	0
RESERVED			VSYNC	HSYNC	FPCLK	LCD2	STN

- Bit 7:5** Reserved
- Bit 4** VSYNC Sync Phase (VSYNC)
0 = LCD2_VSYNC sync phase same as LCD1_VSYNC
1 = LCD2_VSYNC sync phase invert
- Bit 3** HSYNC Sync Phase (HSYNC)
0 = LCD2_HSYNC sync phase same as LCD1_HSYNC
1 = LCD2_HSYNC sync phase invert
- Bit 2** FPCLK Clock (FPCLK)
0 = LCD2_FPCLK clock invert
1 = LCD2_FPCLK clock phase same as LCD1_FPCLK
- Bit 1** LCD2 Panel (LCD2)
0 = Disable LCD2 panel
1 = Enable LCD2 panel
- Bit 0** Continuous line pulse for STN (STN)

FPR50: LCD Overflow Register 1 for Virtual Refresh

Read/Write Address: 3C5h, Index: 50h
Power-on Default: Undefined

This register defines the high order MSB bits of LCD Horizontal Sync Start (FPR54), and LCD Vertical Total (FPR55) registers which are used to control Virtual Refresh timing.

7	6	5	4	3	2	1	0
RESERVED				[10:8] FPR55			FPR54

- Bit 7:4** Reserved
- Bit 3:1** Bit [10:8] of FPR55, Vertical Total of LCD in Virtual Refresh mode
- Bit 0** Bit 8 of FPR54, Horizontal Sync Start of LCD in Virtual Refresh mode (FPR54)

FPR51: LCD Overflow Register 2 for Virtual Refresh

Read/Write Address: 3C5h, Index: 51h
Power-on Default: Undefined

This register defines the overflow bits of FPR52, FPR53, FPR56, and FPR57 registers which are used to control Virtual Refresh timing.

7	6	5	4	3	2	1	0
[10:8] FPR57			[10:8] FPR 56			FPR53	FPR4/52

Bit 7:5 Bit [10:8] of FPR57, Vertical Sync Start of LCD in Virtual Refresh mode

Bit 4:2 Bit [10:8] of FPR56, Vertical Display End of LCD in Virtual Refresh mode

Bit 1 Bit 8 of FPR53, Horizontal Display End of LCD in Virtual Refresh mode (FPR53)

Bit 0 Bit 8 of FPR52, Horizontal Total of LCD in Virtual Refresh mode (FPR52)

FPR52: LCD Horizontal Total for Virtual Refresh

Read/Write Address: 3C5h, Index: 52h

Power-on Default: Undefined

This register defines the bit [7:0] of LCD Horizontal Total. This register is used in Virtual Refresh mode only. It represents one line in TFT LCD and two lines in DSTN LCD. The LSB bit represents a 8-pixel period. The equation to calculate the LCD horizontal total in Virtual Refresh mode is as follows:

For TFT: $LCDHT = (LCD \text{ panel width} + \text{horizontal blanking pixels}) \div 8 - 1$

For DSTN: $LCDHT = (LCD \text{ panel width} * 2 + \text{horizontal blanking pixels}) \div 8 - 1$

7	6	5	4	3	2	1	0
LCD HORIZONTAL TOTAL							

Bit 7:0 LCD Horizontal Total [7:0] in Virtual Refresh mode. Bit 8 of LCD horizontal total is in FPR51 register.

FPR53: LCD Horizontal Display Enable for Virtual Refresh

Read/Write Address: 3C5h, Index: 53h

Power-on Default: Undefined

This register defines the active horizontal display period of LCD in Virtual Refresh mode. It represents one line in TFT LCD and two lines in DSTN LCD. The equation to calculate the LCD horizontal display enable in Virtual Refresh mode:

For TFT: $LCDHDE = (LCD \text{ panel width pixels}) \div 8 - 1$

For DSTN: $LCDHDE = (LCD \text{ panel width} * 2) \div 8 - 1$

7	6	5	4	3	2	1	0
LCD HORIZONTAL DISPLAY ENABLE PERIOD							

Bit 7:0 LCD Horizontal display enable period [7:0] in Virtual Refresh mode. Bit 8 of LCD horizontal display enable is in FPR51 register.

FPR54: LCD Horizontal Sync Start for Virtual Refresh

Read/Write Address: 3C5h, Index: 54h
Power-on Default: Undefined

This register defines the LCD horizontal sync start in Virtual Refresh mode. This register is used to generate the start timing of HYSNC for TFT LCD, or the start timing of LP for DSTN LCD. The value in LCDHSS needs to be larger than the value in LCDHDE. The horizontal sync pulse width is 8 pixels or 16 pixels wide, which is dependent on FPR34 bit 6.

7	6	5	4	3	2	1	0
LCD HORIZONTAL SYNC START PERIOD							

Bit 7:0 LCD Horizontal sync start period [7:0] in Virtual Refresh mode. Bit 8 of LCD horizontal sync start is in FPR50 register.

FPR55: LCD Vertical Total for Virtual Refresh

Read/Write Address: 3C5h, Index: 55h
Power-on Default: Undefined

This register defines the bit [7:0] of LCD Vertical Total. This register is used in Virtual Refresh mode only. The calculation equation of LCD vertical total in Virtual Refresh mode is as follows:

For TFT: $LCDVDT = (\text{LCD panel height} + \text{vertical blank lines}) - 1$

For DSTN: $LCDVDT = ((\text{LCD panel height} \div 2) + \text{vertical blank lines}) - 1$

7	6	5	4	3	2	1	0
LCD VERTICAL TOTAL							

Bit 7:0 LCD Vertical Total [7:0] in Virtual Refresh mode. Bit [10:8] of LCD vertical total are in FPR50 register.

FPR56: LCD Vertical Display Enable for Virtual Refresh

Read/Write Address: 3C5h, Index: 56h
Power-on Default: Undefined

This register defines the LCD active vertical display period in Virtual Refresh mode. The calculation equation of LCD vertical display enable in Virtual Refresh mode is as follows:

For TFT: $LCDVDE = (\text{LCD panel height}) - 1$

For DSTN: $LCDVDE = (\text{LCD panel height} \div 2) - 1$

7	6	5	4	3	2	1	0
LCD VERTICAL DISPLAY ENABLE PERIOD							

Bit 7:0 LCD vertical display enable period [7:0] in Virtual Refresh mode. Bit [10:8] of LCD vertical display enable are in FPR51 register.

FPR57: LCD Vertical Sync Start for Virtual Refresh

Read/Write Address: 3C5h, Index: 57h
Power-on Default: Undefined

This register defines the LCD vertical sync start in Virtual Refresh mode. This register is used to generate the start timing VSYNC for TFT LCD, or the start timing of FP for DSTN LCD. The value in LCDVSS needs to be larger than the value in LDVDE. The vertical sync pulse width is equal to one horizontal scan line.

7	6	5	4	3	2	1	0
LCD VERTICAL SYNC START PERIOD							

Bit 7:0 LCD Vertical sync start period [7:0] in Virtual Refresh mode. Bit [10:8] of LCD vertical sync start are in FPR51 register.

FPR58: EMI Control Register

Read/Write Address: 3C5h, Index: 58h
Power-on Default: 00h

This register defines the EMI control register for LCD flat panels, including LCD Panel I/O pad drive strength, FSPCLK clock delay control.

7	6	5	4	3	2	1	0
RESERVED					LCD	FPSCLK	

Bit 7:2 Reserved

Bit 1:0 FPSCLK Clock Control. Each unit of clock is approximately 1.2ns best case or 2.0ns best case.
00 = normal
01 = FPSCLK delays by 1 unit of clock
10 = FPSCLK delays by 2 unit of clock
11 = FPSCLK delays by 3 unit of clock

FPR59: Panel M-Signal Control Register

Read/Write Address: 3C5h, Index: 59h
Power-on Default: 00h

This register defines the panel M-signal control such as modulation clock and modulation count.

7	6	5	4	3	2	1	0
MCS	MODULATION COUNT						

Bit 7 Modulation Clock Select (MCS)
0 = Select Frame Clock
1 = Select Line Clock

Bit 6:0 Modulation Count. The modulation is generated at a rate that is specified by the modulation count and modulation clock.

FPR5A: SYNC Pulse-widths Adjustment

Read/Write Address: 3C5h, Index: 5Ah
Power-on Default: 00h

This register allows adjust to the HSYNC and VSYNC Pulsewidths.

7	6	5	4	3	2	1	0
HSYNC				VSYNC			

Bit 7:3 Additional HSYNC pulse width in # of character clocks

Bit 2:0 Additional VSYNC pulse width in # of HSYNCs

FPRA0: Panel HW Video Control

Read/Write Address: 3C5h, Index: A0h
Power-on Default: 00h

This register defines the panel video display logic during Virtual Refresh mode. The video display logic will only be activated during Virtual Refresh mode with TFT panel.

7	6	5	4	3	2	1	0
EPV	EHPD	ECK	RGB	EFS	EIC	RESERVED	

Bit 7 Enable Panel Video (EPV)
0 = Disable
1 = Enable

Bit 6 Enable Horizontal Pixel Duplication (EHPD)
0 = Disable
1 = Enable

Bit 5 Enable Color Key (ECK)

0 = Disable

1 = Enable

Bit 4 RGB Format (RGB)

0 = YUV Format

1 = RGB Format

Bit 3 Enable Full screen video (EFS)

0 = Disable

1 = Enable

Bit 2 Enable 8-bit index color mode (only works in Virtual Refresh mode) (EIC)

0 = Disable

1 = Enable

Bit 1:0 Reserved

FPRA1: Panel Video Color Key

Read/Write Address: 3C5h, Index: A1h

Power-on Default: 00h

This register defines the panel video color key [7:0]

7	6	5	4	3	2	1	0
PANEL VIDEO COLOR KEY [7:0]							

Bit 7:0 Panel Video Color Key[7:0]

FPRA2: Panel Video Color Key

Read/Write Address: 3C5h, Index: A2h

Power-on Default: 00h

This register defines the panel video color key [15:8]

7	6	5	4	3	2	1	0
PANEL VIDEO COLOR KEY [15:8]							

Bit 7:0 Panel Video Color Key[15:8]

FPRA3: Panel Video Color Key Mask

Read/Write Address: 3C5h, Index: A3h

Power-on Default: 00h

This register defines the panel video color key mask [7:0]

7	6	5	4	3	2	1	0
PANEL VIDEO COLOR KEY MASK [7:0]							

Bit 7:0 Panel Video Color Key Mask[7:0]

FPRA4: Panel Video Color Key Mask

Read/Write Address: 3C5h, Index: A4h
Power-on Default: 00h

This register defines the panel video color key mask [15:8]

7	6	5	4	3	2	1	0
PANEL VIDEO COLOR KEY MASK [15:8]							

Bit 7:0 Panel Video Color Key Mask[15:8]

FPRA5: Panel Video Red Constant

Read/Write Address: 3C5h, Index: A5h
Power-on Default: EDh

This register defines the panel video Red Constant

7	6	5	4	3	2	1	0
PANEL VIDEO RED CONSTANT [7:0]							

Bit 7:0 Panel Video Red Constant [7:0]

FPRA6: Panel Video Green Constant

Read/Write Address: 3C5h, Index: A6h
Power-on Default: EDh

This register defines the panel video green constant

7	6	5	4	3	2	1	0
PANEL VIDEO GREEN CONSTANT [7:0]							

Bit 7:0 Panel Video Green Constant [7:0]

FPRA7: Panel Video Blue Constant

Read/Write Address: 3C5h, Index: A7h
Power-on Default: EDh

This register defines the panel video Blue Constant

7	6	5	4	3	2	1	0
PANEL VIDEO BLUE CONSTANT [7:0]							

Bit 7:0 Panel Video Blue Constant [7:0]

FPRA8: Panel Video Top Boundary

Read/Write Address: 3C5h, Index: A8h
Power-on Default: 00h

This register defines the panel video top boundary

7	6	5	4	3	2	1	0
PANEL VIDEO TOP BOUNDARY [7:0]							

Bit 7:0 Panel Video Top Boundary [7:0]

FPRA9: Panel Video Left Boundary

Read/Write Address: 3C5h, Index: A9h
Power-on Default: 00h

This register defines the panel video left boundary

7	6	5	4	3	2	1	0
PANEL VIDEO LEFT BOUNDARY [7:0]							

Bit 7:0 Panel Video Left Boundary [7:0]

FPRAA: Panel Video Bottom Boundary

Read/Write Address: 3C5h, Index: AAh
Power-on Default: 00h

This register defines the panel video bottom boundary

7	6	5	4	3	2	1	0
PANEL VIDEO BOTTOM BOUNDARY [7:0]							

Bit 7:0 Panel Video Bottom Boundary [7:0]

FPRAB: Panel Video Right Boundary

Read/Write Address: 3C5h, Index: ABh
Power-on Default: 00h

This register defines the panel video Right boundary

7	6	5	4	3	2	1	0
PANEL VIDEO RIGHT BOUNDARY [7:0]							

Bit 7:0 Panel Video Right Boundary [7:0]

FPRAC: Panel Video Top and Left Boundary Overflow

Read/Write Address: 3C5h, Index: ACh
Power-on Default: 00h

This register defines the panel video top and left boundary overflow

7	6	5	4	3	2	1	0
PVLB			RESERVED			PVTB	

Bit 7:5 Panel Video Left Boundary [10:8] (PVLB)

Bit 4:3 Reserved

Bit 2:0 Panel Video Top Boundary [10:8] (PVTB)

FPRAD: Panel Video Bottom and Right Boundary Overflow

Read/Write Address: 3C5h, Index: ADh
Power-on Default: 00h

This register defines the panel video bottom and right boundary overflow

7	6	5	4	3	2	1	0
PVRB			RESERVED			PVBB	

Bit 7:5 Panel Video Right Boundary [10:8] (PVRB)**Bit 4:3** Reserved**Bit 2:0** Panel Video Bottom Boundary [10:8] (PVBB)

FPRAE: Panel Video Vertical Stretch Factor

Read/Write Address: 3C5h, Index: AEh
Power-on Default: 00h

This register defines the panel video vertical stretch factor.

7	6	5	4	3	2	1	0
PANEL VIDEO VERTICAL STRETCH FACTOR [7:0]							

Bit 7:0 Panel Video Vertical Stretch Factor [7:0]. The stretch factor equals to:
 $S/D * 256$.
note: when stretch factor is set to 0, it becomes a 1-to-1 stretch.

FPRAF: Panel Video Horizontal Stretch Factor

Read/Write Address: 3C5h, Index: AFh
Power-on Default: 00h

This register defines the panel video horizontal stretch factor

7	6	5	4	3	2	1	0
PANEL VIDEO HORIZONTAL STRETCH FACTOR [7:0]							

Bit 7:0 Panel Video Horizontal Stretch Factor [7:0] The stretch factor equals to:
 $S/D * 256$. Note: when stretch factor is set to 0, it becomes a 1-to-1 stretch.**Memory Control Registers**

MCR60: Memory Control

Read/Write Address: 3C5h, Index: 60h
Power-on Default: 00h

This register specifies memory control for Memory Address Wrap Around, DRAM refresh, VGA to memory burst write, and synchronization. This register also includes RAMDAC Write/Read Command Pulse Width select.

7	6	5	4	3	2	1	0
TRDL	BWC	RAM	DVGA	VGAF	R	DDRR	DRC

- Bit 7** TRDL - Precharge termination cycle (TRDL)
0 = TRDL 2 clock (default)
1 = TRDL 1 clock
- Bit 6** Block Write Control (BWC)
0 = Block write enabled
1 = Block Write not enabled (default)
- Bit 5** RAMDAC Write/Read Command Pulse Width Select (RAM)
0 = Command Pulse is 4 MCLK high and 12 MCLK low
1 = Command Pulse is 8 MCLK high and 24 MCLK low
- Bit 4** Disable VGA to memory burst write (DVGA)
0 = Enable
1 = Disable
- Bit 3** VGA FIFO Empty Level Request Select. VGA FIFO is 8 level deep. (VGAF)
0 = VGA FIFO request if VGA FIFO is two level empty
1 = VGA FIFO request if VGA FIFO is four level empty
- Bit 2** Reserved (R)
- Bit 1** Disable DRAM Refresh Request (DDRR)
0 = Enable
1 = Disable
- Bit 0** DRAM Refresh Control (DRC)
0 = Normal DRAM refresh
1 = Force to 1 DRAM refresh per scan line

MCR61: Memory Bank Address High

Read/Write Address: 3C5h, Index: 61h
Power-on Default: 00h

This register specifies the high order memory bank address for non-linear addressing (or banking) mode (SCR18 bit 0 = 0).

7	6	5	4	3	2	1	0
MEMORY BANK ADDRESS HIGH							

Bit 7:0 Memory Bank Address High

Specifies the high-order address for memory access in non-linear addressing (or banking) mode. The host will take these bits append with address [15:0] to form a 22 bits address (4Mbyte).

MCR62: Memory Type and Timing Control

Read/Write Address: 3C5h, Index: 62h

Power-on Default: This is a power-on configurable register (by RESET)

Lynx3DM supports both internal and external memory. This register specifies the memory type and memory timing control. This register is power-on configurable by MD [7:0] of memory data bus.

7	6	5	4	3	2	1	0
IMDS		IMDC		TBWC	EMBC	IMPD	IMR

Bit 7:6 Internal Memory DRAM size (bit 7 not used) (IMDS)
 10 = 8 Mbyte
 11 = 4 Mbyte (default)
 (power on configuration MD [7:6])

Bit 5:4 Internal Memory DRAM column size (IMDC)
 0x = 1K DRAM column
 10 = 512 DRAM column
 11 = 256 DRAM column (default)
 (power on configuration MD [3])

Bit 3 TBWC - Internal Memory Block Write Cycle Time (TBWC)
 0 = 1 MCLK
 1 = 2 MCLK (default)
 (power-on configuration MD [3])

Bit 2 Enable Memory Bus Cycle (EMBC)
 0 = Enable 128-bit memory bus cycle
 1 = Enable 128-bit memory bus cycle
 (power-on configuration MD [2])

Bit 1 Tras - Internal Memory Active to Precharge Delay (IMPD)
 0 = 7 MCLK
 1 = 6 MCLK (default)
 (power-on configuration MD [1])

Bit 0 TRC - Internal Memory Refresh to Command Delay (IMR)
 0 = 10 MCLK
 1 = 9 MCLK (default)
 (power-on configuration MD [0])

MCR76: Memory Type and Timing Control

Read/Write Address: 3C5h, Index: 76h

Power-on Default: This is a power-on configurable register (by RESET)

7	6	5	4	3	2	1	0
EMDS		EMDC		TBWC	EEM	EMPD	EMR

- Bit 7:6** External memory DRAM size (bit 7 not used)
 00 = 8 Mbyte
 01 = 16 Mbyte
 10 = 2 Mbyte
 11 = 4 Mbyte (default)
 (power on configuration MD [31:30])
- Bit 5:4** External Memory DRAM column size (EMDC)
 0x = 1K DRAM column
 10 = 512 DRAM column
 11 = 256 DRAM column (default)
 (power on configuration MD [29:28])
- Bit 3** TBWC - External Memory Block Write Cycle Time (TBWC)
 0 = 1 MCLK
 1 = 2 MCLK (default)
 (power-on configuration MD [27])
- Bit 2** Enable external memory (EEM)
 0 = Disenable external memory
 1 = Enable external memory (default)
 (power-on configuration MD [26])
- Bit 1** Tras - Internal Memory Active to Precharge Delay (EMPD)
 0 = 7 MCLK
 1 = 6 MCLK (default)
 (power-on configuration MD [25])
- Bit 0** TRC - Internal Memory Refresh to Command Delay (EMR)
 0 = 10 MCLK
 1 = 9 MCLK (default)
 (power-on configuration MD [24])

Clock Control Registers

CCR65: TV Encoder Control Register

Read/Write Address: 3C5h, Index: 65h
 Power-on Default: 00h

This register specifies the various TV controls.

7	6	5	4	3	2	1	0
SVHS	CVBS	TVEE	CRTDAC	CRRC	CRTDAC	TVCS	CHOS

- Bit 7** SVHS TV enable (SVHS)
0 = SVHS TV off
1 = SVHS TV on
- Bit 6** CVBS TV enable (CVBS)
0 = CVBS TV off
1 = CVBS TV on
- Bit 5** TV Encoder Enable (TVEE)
0 = Disable TV Encoder (TVCLK disable)
1 = Enable TV Encoder
- Bit 4, 2** 00 = Connect CRTRGB from video mixer to CRTDAC
01 = Connect TVRGB (CRTRGB go through flicker reduction) to CRTDAC
10 = Connect LCDRGB from fpbkend to CRTDAC
- Bit 3** Color RAM read control (CRRC)
0 = Read from CRT color RAM
1 = Read from LCD color RAM
- Bit 1** TV clock select (TVCS)
0 = TVCLK generated from VCLK
1 = TVCLK generated from REFCLK input
- Bit 0** CRT HSYNC output select (CHOS)
0 = CRTHSYNC output to CRTHSYNC pin
1 = CRT composite SYNC to CRTHSYNC pin

CCR66: RAM Control and Function On/Off Register

Read/Write Address: 3C5h, Index: 66h
Power-on Default: 00h

7	6	5	4	3	2	1	0
ROOC		RWCB2		CRT RAM		MCE	DEE

- Bit 7:6** RAMLUT On/Off Control (ROOC)
 0 0 Both RAM ON*~
 1 0 LCD RAM OFF
 0 1 CRT RAM OFF
 1 1 Both RAM OFF
- Bit 5:4** RAM Write Control Bits (RWCB2)
 0 0 Write both RAM (CRT/LCD)
 1 0 Write CRT RAM only
 0 1 Write LCD RAM only
 1 1 Reserve

Bit 3:2 CRT RAM 8/6 Bits and Gamma Control
 0 0 6-bits RAM
 1 0 8-bits RAM
 x 1 Gamma correct ON

Bit 1 Motion Comp Enable (MCE)
 1 = Disable MComp*~
 0 = Enable MComp
 Include MCCLK off

Bit 0 3D DrawEng Enable (DEE)
 1 = Disable 3DEng*~
 0 = Enable 3DEng
 Include 3DMCLK and 3DMCLKB off

CCR67: For Test Purpose Only

Read/Write Address: 3C5h, Index: 67h
 Power-on Default: 00h

7	6	5	4	3	2	1	0
PDFC		TIFC	LPDFC	BHPS	RESERVED		

Bit 7:6 11 = The power down frame counter is incremented by toggle CCR67_5 (PDFC)
 10 = The power down frame counter is incremented by Vsync

Bit 5 Toggle this bit will increment the frame counter in test mode (CCR67_[7:6] = 11) (TIFC)

Bit 4 1 = To load the power down frame counter the following value will be loaded into the frame counter: (CCR67_[2:0], CCR66_[7:0], CCR65_[7:4], 4'b0000) (LPDFC)
 0 = Normal operation. The frame counter increment by Vsync

Bit 3 1 = Bypass hardware power sequencer for the FPdata. If select software power dequence this bit will not function (BHPS)
 0 = LCD power sequencer will function

Bit 2:0 Reserved

CCR68: Clock Control 1

Read/Write Address: 3C5h, Index: 68h
 Power-on Default: C0h

This register is used to select clock frequencies and pulse-width control.

7	6	5	4	3	2	1	0
VCLKF		ISO	CLK	SELECT VCLK	SELECT MCLK		

Bit 7:6 Select VCLK frequency based on the following table (VCLKF)

Bit [7:6]	~EXCKE N	VCLK frequency
00	1	VCLK is selected from VGA 3C2h register
01	1	VCLK is selected from programmable VCLK registers: CCR6C and CCR6D
10	1	VCLK is selected from 17.734 MHz
11	1	VCLK is selected from 14.131818 MHz
xx	0	VCLK is selected from CKIN input

Bit 5 Enable ISO standard at VGA modes. This bit is designed to increase the CRT screen refresh rate to ISO standard at VGA modes. This bit is used only when CCR68 bit [7:6] = 00b. (ISO)
 0 = Standard VGA frequency which controlled by 3C2h bit [3:2]
 1 = ISO frequency which selected by 3C2h bit [3:2]

CCR68 Bit 5	3C2h Bit [3:2]	VCLK frequency
0	00	25.180 MHz
0	01	28.325 MHz
1	00	31.500 MHz
1	01	35.484 MHz

Bit 4 Select 8-dot character clock and disable dot clock divided by 2 function. This bit is used when LCD or TV is selected (determined by FPR31 [2:0]). When this bit set to "1", the bit 3 and bit 0 setting of VGA Clocking Mode Register will be ignored. (CLK)
 0 = Character clock and dot clock are controlled by VGA clocking mode register
 1 = Select 8-dot character clock and non-divided by 2 dot clock

Bit 3:2 Select MCLK high pulse width
 00 = default value
 01 = reduce 1 ns high time
 10 = increase 1 ns high time
 11 = increase 2 ns high time

Bit 1:0 Select VCLK high pulse width
 00 = default value
 01 = reduce 1 ns high time
 10 = increase 1 ns high time
 11 = increase 2 ns high time

CCR69: Clock Control 2

Read/Write Address: 3C5h, Index: 69h
 Power-on Default: 80h

This register is used to select Virtual Refresh clock frequency, DRAM refresh clock frequency during sleep mode and standby mode, and HSYNC & VSYNC control during sleep mode.

7	6	5	4	3	2	1	0
TVCLK	TDSS	LVDSCLK		DRAM	SHVSM	SELECT VRCLK	

- Bit 7** TVCLK or BLANK Select (TVCLK)
 0 = Select BLANK output for pin 158
 1 = Select TVCLK to external analog NTSC/PAL TV encoder via pin 158. TVCLK is equal to ¼ of VCLK, where VCLK is programmable by CCR6C and CCR6D registers.
- Bit 6** Test Data Source Select. This bit is used for LSI testing only. (TDSS)
 0 = Select index color data for test data
 1 = Select direct color data for test data
- Bit 5:4** Select LVDSCLK output clock source when ~EXCKIN = 1.
 00 = Select inverted VRCLK
 01 = Output is always low
 10 = Select inverted WFIFO clock (same as inverted VCLK)
 11 = Select WFIFO clock (same as VCLK)
- Bit 3** Select refresh clock source to control DRAM refresh during sleep mode and standby mode. It is recommended to select external 32 KHz refresh clock to achieve highest power saving. (DRAM)
 0 = Select external 32 KHz refresh clock
 1 = Select internal PLL. During standby or sleep mode, the VCLK and MCLK frequency are selected by PDR20 [5:4]. MCLK is used to replace external 32 KHz refresh clock to control DRAM refresh.
- Bit 2** Select HSYNC and VSYNC during Sleep Mode. (PDR20 bit 7 = 1) This bit is used to support VESA DPMS during Sleep Mode. Lynx3DM will automatically support VESA DPMS Standby Mode during its internal Standby Mode. (SHVSM)

Bit 2	DPMS STATE	HSYNC	VSYNC
0	Suspend	Pulses	No Pulses
1	Off	No Pulses	No Pulses

- Bit 1:0** Select Virtual Refresh clock (VRCLK). The VRCLK is used to generate the timing sequence of LCD interface signals and control logic during Virtual Refresh mode.

Bit [1:0]	VRCLK Frequency
00	VCLK2
01	½ MCLK
10	MCLK
11	programmable Video Clock ¹

Notes:

- In TV display mode, VCLK is set up as 14.31818 MHz clock from CKIN input (CCR68 [7:6] = 11b) to control TV timing. VRCLK could be chosen from programmable Video Clock which is selected by CCR6C and CCR6D registers by programming CCR69 [1:0] = 11b.

2. In non-Virtual Refresh mode (FPR31 bit 7 = 0), VRCLK is the same as VCLK.

CCR6A: MCLK Numerator Register

Read/Write Address: 3C5h, Index: 6Ah
Power-on Default: 0Fh

This register specifies the 8-bit numerator value of MCLK frequency (MNR). The MNR value is used to calculate the programmable MCLK frequency as follow:

7	6	5	4	3	2	1	0
CALCULATE MCLK FREQUENCY [8]							

Bit 7:0 Specify the 8-bit numerator value to calculate the selected MCLK frequency. The power-on default of this register is 5Ah. Along with CCR6B, the default frequency is set to 40.27 MHz.

CCR6B: MCLK Denominator Register

Read/Write Address: 3C5h, Index: 6Bh
Power-on Default: 04h

This register specifies the 6-bit denominator value of MCLK frequency (MDR). The MDR value is used to calculate the programmable MCLK frequency as follow:

7	6	5	4	3	2	1	0
RESERVED		CALCULATE MCLK FREQUENCY [6]					

Bit 7:6 Reserved

Bit 5:0 Specify the 6-bit denominator value to calculate the selected MCLK frequency. The power-on default of this register is 20h. Along with CCR6A, the default frequency is set to 40.27 MHz.

CCR6C: VCLK Numerator Register

Read/Write Address: 3C5h, Index: 6Ch
Power-on Default: 1Fh

This register specifies the numerator value of VCLK frequency (VNR). The VNR value is used to calculate the programmable VCLK frequency as follow:

7	6	5	4	3	2	1	0
CALCULATE VCLK FREQUENCY							

Bit 7:0 Specify the numerator value to calculate the selected VCLK frequency. The power-on default setting of this register is 5Bh. Along with CCR6D, the default frequency is set to 28.325 MHz.

CCR6D: VCLK Denominator Register

Read/Write Address: 3C5h, Index: 6Dh
Power-on Default: 0Fh

This register specifies the 6-bit denominator (VDR) value of and 1 bit post scalar (PS) value of VCLK frequency. The VDR value is used to calculate the programmable VCLK frequency. The post scalar is used to support VCLK frequencies which originally need high and even VDR value. With PS enabled, the revised VDR value should be set half of the original VDR value in order to reduce potential jitters.

7	6	5	4	3	2	1	0
EPS	EVC0	VCLK FREQUENCY [6]					

Bit 7 Enable Post Scalar. When post scalar is enabled, the revised VDR value is 1/2 of its original VDR value. (EPS)
0 = Disable
1 = Enable

Bit 6 Enable second VC0 (EVC0)
0 = Disable
1 = Enable

Bit 5:0 Specify the 6-bit denominator value to calculate the selected VCLK frequency. The power-on default setting of this register is 2Eh. Along with CCR6C, the default frequency is set to 28.325 MHz.

CCR6E: VCLK2 Numerator Register

Read/Write Address: 3C5h, Index: 6Eh
Power-on Default: 5Ah

This register specifies the 8-bit numerator value of VCLK2 frequency (VCLK2NR). The VCLK2NR value is used to calculate the programmable VCLK2 frequency as follow:

7	6	5	4	3	2	1	0
VCLK2 FREQUENCY [8]							

Bit 7:0 Specify the 8-bit numerator value to calculate the selected VCLK2 frequency. Along with CCR6F, the default frequency is set to 40.27 MHz.

CCR6F: VCLK2 Denominator Register

Read/Write Address: 3C5h, Index: 6Fh
Power-on Default: 20h

This register specifies the 6-bit denominator value of VCLK2 frequency (VCLK2DR). The VCLK2DR value is used to calculate the programmable VCLK2 frequency as follow:

7	6	5	4	3	2	1	0
EPS	EVC0	CALCULATE VCLK2 FREQUENCY [6]					

Bit 7 Enable Post Scalar. When post scalar is enabled, the revised VDR value is 1/2 of its original VDR value. (EPS)
0 = Disable
1 = Enable

Bit 6 Enable second VC0 (EVC0)
0 = Disable
1 = Enable

Bit 5:0 Specify the 6-bit denominator value to calculate the selected VCLK2 frequency. Along with CCR6E, the default frequency is set to 40.27 MHz.

CCR7A-CCR7C: TV and RAMDAC Testing Power

Read/Write Address: 3C5h, Index: 7Ah-7Ch
Power-on Default: 00h

7	6	5	4	3	2	1	0
TV AND RAMDAC TESTING POWER ON RESET = 00							

Bit 7:0 TV and RAMDAC testing power on reset = 00

Note: See Appendix E for further details.

CCR7D: Control Registers for TV and RAMDAC Testing

Read/Write Address: 3C5h, Index: 7Dh
Power-on Default: 00h

7	6	5	4	3	2	1	0
TV	SVHS	CVBS	MD	VCLK	MCLK	RESERVED	

Bit 7 TV Detect (TV)
0 = Normal operation
1 = Use CCR7A, CCR7B, and CCR7C data to check for TV detect

Bit 6 Read only for SVHS Detect (SVHS)

Bit 5 Read only for CVBS detect (CVBS)

Bit 4 Monitor Detect (MD)
0 = Normal operation

1 = Use CCR7A, CCR7B, and CCR7C data to check for monitor detect

Bit 3 External VCLK
0 = Normal operation
1 = Enable external VCLK

Bit 2 External MCLK
0 = Normal operation
1 = Enable external MCLK

Bit 1:0 Reserved
Note: See Appendix E for further details.

General Purpose Registers

GPR70: Scratch Pad Register 1

Read/Write Address: 3C5h, Index: 70h
Power-on Default: Undefined except for bit [3:0] which are power-on configurable (by RESET)

This register can be used as general purpose scratch bits.

7	6	5	4	3	2	1	0
SCRATCH PAD REG BITS				SCRATCH PAD REG BITS MD [19:16]			

Bit 7:4 Scratch pad register bits. This register can be used as general purpose bits.

Bit 3:0 Scratch pad register bits. These lower 4 bits are also connected to MD [19:16] of memory data bus. The external pull-down on MD lines will generate a logic "0", and internal pull-up will generate a logic "1" during power-on reset period. For power-on configuration, please refer to Initialization chapter of this data book.

GPR71: Scratch Pad Register 2

Read/Write Address: 3C5h, Index: 71h
Power-on Default: Undefined

This register can be used as general purpose scratch bits.

7	6	5	4	3	2	1	0
SCRATCH PAD 2 REGISTER							

Bit 7:0 Scratch Pad 2 register. This register can be used as general purpose scratch bits.

GPR72: User Defined Register 1 for DDC2/ I2C

Read/Write Address: 3C5h, Index: 72h

Power-on Default: 00h

This register is used for user defined registers: USR1/SDA and USR0/SCL. The SDA and SCL can be used for VESA DDC2 / I2C serial communication port.

7	6	5	4	3	2	1	0
RESERVED		EUSR1	EUSR0	USR1S	USR0S	USR1W	USR0W

Bit 7:6 Reserved

Bit 5 Enable USR1/SDA Port (EUSR1)
0 = Disable use of bit 1 of this register
1 = Enable use of bit 1 of this register

Bit 4 Enable USR0/SCL Port (EUSR0)
0 = Disable use of bit 0 of this register
1 = Enable use of bit 0 of this register

Bit 3 USR1/SDA Status (Read only). This bit can be used for DDC2/I2C Data. (USR1S)
0 = pin USR1/SDA is low
1 = pin USR1/SDA is tri-stated

Bit 2 USR0/SCL Status (Read only). This bit can be used for DDC2/I2C Clock. (USR0S)
0 = pin USR0/SCL is low
1 = pin USR0/SCL is tri-stated

Bit 1 USR1/SDA Write. Pin 131 can be used for DDC2/I2C Data. When pin USR1/SDA is tri-stated, other devices may drive this line. The actual state of the pin USR1/SDA is read via bit 3 of this register. (USR1W)
0 = pin USR1/SDA is driven low
1 = pin USR1/SDA is tri-stated

Bit 0 USR0/SCL Write. Pin 132 can be used for DDC2/I2C Clock. When pin USR0/SCL is tri-stated, other devices may drive this line. The actual state of the pin USR0/SCL is read via bit 2 of this register. (USR0W) 0 = pin USR0/SCL is driven low
1 = pin USR0/SCL is tri-stated

Note: See Appendix D for further details.

GPR73: User Defined Register 2

Read/Write Address: 3C5h, Index: 73h

Power-on Default: 00h

This register can be used to control user programmable outputs: USR2 and USR3 pins.

7	6	5	4	3	2	1	0
RESERVED		USR3P	USR2P	USER3	USER2	USR3W	USR2W

- Bit 7:6** Reserved
- Bit 5** Enable USR3 Port (USR3P)
0 = Disable use of bit 1 of this register
1 = Enable use of bit 1 of this register
- Bit 4** Enable USR2 Port (USR2P)
0 = Disable use of bit 0 of this register
1 = Enable use of bit 0 of this register
- Bit 3** USER3 Status (Read only) (USER3)
0 = pin USR3 is low
1 = pin USR3 is tri-stated
- Bit 2** USER2 Status (Read only) (USER2)
0 = pin USR2 is low
1 = pin USR2 is tri-stated
- Bit 1** USR3 Write. When pin USR3 is tri-stated, other devices may drive this line. The actual state of the pin USR3 is read via bit 3 of this register. (USR3W)
0 = pin USR3 is driven low
1 = pin USR3 is tri-stated
- Bit 0** USR2 Write. When pin USR2 is tri-stated, other devices may drive this line. The actual state of the pin USR2 is read via bit 2 of this register. (USR2W)
0 = pin USR2 is driven low
1 = pin USR2 is tri-stated

GPR74: Scratch Pad Register 3

Read/Write Address: 3C5h, Index: 74h
Power-on Default: Undefined

This register can be used as general purpose scratch bits.

7	6	5	4	3	2	1	0
SCRATCH PAD 3 REGISTER							

Bit 7:0 Scratch Pad 3 register. This register can be used as general purpose scratch bits.

GPR75: Scratch Pad register 4

Read/Write Address: 3C5h, Index: 75h
Power-on Default: Undefined

This register can be used as general purpose scratch bits.

7	6	5	4	3	2	1	0
SCRATCH PAD 4 REGISTER							

Bit 7:0 Scratch Pad 4 register. This register can be used as general purpose scratch bits.

Pop-up Icon and Hardware Cursor Registers

PHR80: Pop-up Icon and Hardware Cursor Pattern Location Low

Read/Write Address: 3C5h, Index: 80h
Power-on Default: Undefined

This register specifies the low 8 bits of the address for pop-up icon and Hardware Cursor Pattern Location, which is a 11-bit register. The high order 3 bits are specified in the PHR81 [2:0] register.

7	6	5	4	3	2	1	0
POP-UP ICON AND HARDWARE CURSOR PATTERN							

Bit 7:0 Pop-up Icon and Hardware Cursor Pattern Location Low. The PHR80 and PHR81 [2:0] registers allocate 2KB off-screen memory within the maximum 4MB of physical memory. The lower 1KB is used to store Pop-up Icon image. The upper 1KB is used to store Hardware Cursor image

PHR81: Hardware Cursor Enable & PI/HWC Pattern Location High

Read/Write Address: 3C5h, Index: 81h
Power-on Default: 0xh

This register specifies the hardware cursor enable and the high-order 3 bits of the address for pop-up icon and Hardware Cursor Pattern Location, which is a 11-bit register. The low order 8 bits are specified in the PHR80 register.

7	6	5	4	3	2	1	0
HCE	R	POP-UP ICON					

Bit 7 Hardware Cursor Enable (HCE)
0 = Disable (default)
1 = Enable

Bit 6 Reserved (R)

Bit 5:0 Pop-up Icon and Hardware Cursor Pattern Location High. The PHR80 and PHR81 [2:0] registers allocate 2KB off-screen memory within the maximum 32MB of physical memory. The lower 1KB is used to store Pop-up Icon image. The upper 1KB is used to store Hardware Cursor image.

Pop-up Icon Registers

POP82: Pop-up Icon Control

Read/Write Address: 3C5h, Index: 82h
Power-on Default: 00h

This register specifies the control for pop-up icon.

7	6	5	4	3	2	1	0
PUIE	PUIZE	RESERVED					

Bit 7 Pop-up Icon Enable (PUIE)
0 = Disable
1 = Enable

Bit 6 Pop-up Icon Zoom Enable (PUIZE)
0 = Normal. (Pop-up Icon size is 64x64x2)
1 = zoom up the Pop-up Icon size by 2. (Pop-up Icon size is 128x128x2)

Bit 5:0 Reserved

POP83: Reserved

Read/Write Address: 3C5h, Index: 83h
Power-on Default: Undefined

This register is reserved.

7	6	5	4	3	2	1	0
RESERVED							

Bit 7:0 Reserved

POP84: Pop-up Icon Color 1

Read/Write Address: 3C5h, Index: 84h
Power-on Default: Undefined

This register specifies the color1 for pop-up icon.

7	6	5	4	3	2	1	0
POP-UP ICON COLOR1							

Bit 7:0 Pop-up icon color1.

POP85: Pop-up Icon Color 2

Read/Write Address: 3C5h, Index: 85h
Power-on Default: Undefined

This register specifies the color2 for pop-up icon.

7	6	5	4	3	2	1	0
POP-UP ICON COLOR2							

Bit 7:0 Pop-up icon color2.

POP86: Pop-up Icon Color 3

Read/Write Address: 3C5h, Index: 86h
Power-on Default: Undefined

This register specifies the color3 for pop-up icon.

7	6	5	4	3	2	1	0
POP-UP ICON COLOR3							

Bit 7:0 Pop-up icon color3.

POP90: Pop-up Icon Start X - Low

Read/Write Address: 3C5h, Index: 90h
Power-on Default: Undefined

This register specifies Pop-up icon location X start [7:1]. The pop icon can only be moved in X direction by increments of 2 pixels. Bit [0] has no effect

7	6	5	4	3	2	1	0
POP-UP ICON X START [7:0]							NE

Bit 7:1 Pop-up icon X start [7:1]

Bit 0 Has no effect (NE)

POP91: Pop-up Icon Start X - High

Read/Write Address: 3C5h, Index: 91h
Power-on Default: Undefined

This register specifies Pop-up icon location X start [11:8]

7	6	5	4	3	2	1	0
RESERVED				POP-UP ICON X START			

Bit 7:3 Reserved

Bit 2:0 Pop-up icon X start [10:8]

POP92: Pop-up Icon Start Y - Low

Read/Write Address: 3C5h, Index: 92h
Power-on Default: Undefined

This register specifies Pop-up icon location Y start [7:0]

7	6	5	4	3	2	1	0
POP-UP ICON Y START							

Bit 7:0 Pop-up icon Y start [7:0]

POP93: Pop-up Icon Start Y - High

Read/Write Address: 3C5h, Index: 93h
Power-on Default: Undefined

This register specifies Pop-up icon location Y start [11:8]

7	6	5	4	3	2	1	0
RESERVED				POP-UP ICON Y START			

Bit 7:3 Reserved

Bit 2:0 Pop-up icon Y start [10:8]

Hardware Cursor Registers

HCR88: Hardware Cursor Upper Left X Position - Low

Read/Write Address: 3C5h, Index: 88h
Power-on Default: 00h

This register specifies the lower 8-bit upper left X position for hardware cursor.

7	6	5	4	3	2	1	0
HARDWARE CURSOR X POSITION LOW ORDER							

Bit 7:0 Hardware Cursor X position low order 8 bits. The high order 3 bits are in HCR89[2:0].

HCR89: Hardware Cursor Upper Left X Position- High

Read/Write Address: 3C5h, Index: 89h
Power-on Default: 00h

This register specifies the upper left X position for hardware cursor.

7	6	5	4	3	2	1	0
RESERVED				HCUL	HCXP		

Bit 7:4 Reserved

Bit 3 Hardware Cursor Upper Left X Position Boundary Select (HCUL)
0 = hardware cursor is within the screen left side boundary. {HCR89[2:0], HCR88[7:0]} specify the X position of the hardware cursor from the left side boundary.
1 = hardware cursor is partially or totally outside of the left side screen boundary. HCR88 [4:0] specify how many pixels of the hardware cursor are outside the left side screen boundary.

Bit 2:0 Hardware Cursor X position high-order 3 bits. The low order 8 bits are specified in the HCR88 register. (HCXP)

HCR8A: Hardware Cursor Upper Left Y Position - Low

Read/Write Address: 3C5h, Index: 8Ah
Power-on Default: 00h

This register specifies the upper left Y position for hardware cursor.

7	6	5	4	3	2	1	0
HARDWARE CURSOR Y POSITION LOW ORDER							

Bit 7:0 Hardware Cursor Y position low order 8 bits. The high order 3 bits are in HCR8B [2:0].

HCR8B: Hardware Cursor Upper Left Y Position - High

Read/Write Address: 3C5h, Index: 8Bh
Power-on Default: 00h

This register specifies the upper left Y position for hardware cursor.

7	6	5	4	3	2	1	0
RESERVED				HCUL	HCYP		

Bit 7:4 Reserved

- Bit 3** Hardware Cursor Upper Left Y Boundary Select (HCUL)
 0 = hardware cursor is within the screen top side boundary. {HCR8B[2:0], HCR8A[7:0]} specify the Y position of the hardware cursor from the top side boundary.
 1 = hardware cursor is partially or totally outside of the top side screen boundary. HCR8A [4:0] specify how many pixels of the hardware cursor are outside the top side screen boundary.
- Bit 2:0** Hardware Cursor Y position high-order 3 bits. The low order 8 bits are specified in the HCR8A register. (HCYP)

HCR8C: Hardware Cursor Foreground Color

Read/Write Address: 3C5h, Index: 8Ch
 Power-on Default: 00h

This register specifies the foreground color for hardware cursor. Hardware Cursor is always in 24-bit color. The 24-bit color is the expansion of 3:3:2 RGB into 8:8:8 RGB color.

7	6	5	4	3	2	1	0
HARDWARE CURSOR FOREGROUND COLOR							

- Bit 7:0** Hardware Cursor foreground color
 This register defines 3:3:2 8-bit RGB of the Hardware Cursor foreground color.

HCR8D: Hardware Cursor Background Color

Read/Write Address: 3C5h, Index: 8Dh
 Power-on Default: 00h

This register specifies the background color for hardware cursor. Hardware Cursor is always in 24-bit color. The 24-bit color is the expansion of 3:3:2 RGB into 8:8:8 RGB color.

7	6	5	4	3	2	1	0
HARDWARE CURSOR BACKGROUND COLOR							

- Bit 7:0** Hardware Cursor background color
 This register defines 3:3:2 8-bit RGB of the Hardware Cursor background color.

Extended CRT Control Registers

CRT30: CRTC Overflow and Interlace Mode Enable

Read/Write Address: 3?5h, Index: 30h
 Power-on Default: 00h

This register specifies the CRTC overflow registers and Interlace Mode Enable.

7	6	5	4	3	2	1	0
IME	CRTHR	CRT DISPLAY	CVTR	CVDER	CVBS	CVRS	

- Bit 7** Interlace Mode Enable (IME)
0 = Disable
1 = Enable
- Bit 6** Bit 8 of the horizontal register. Bit [7:0] are located at CRTC register index 00.
- Bit 5:4** Bit [17:16] of the CRT display starting address. The lower order 16-bit are located in CRTC register index 0Ch and 0Dh.
- Bit 3** Bit 10 of the CRT vertical total register. The lower bit [9:0] are defined in CRTC register index 07h and 06h. (CVTR)
- Bit 2** Bit 10 of the CRT vertical display end register. The lower bit [9:0] are defined in CRTC register index 12h and 07h. (CVDER)
- Bit 1** Bit 10 of the CRT vertical blank start. The lower bit [9:0] are defined in CRTC register index 15 h, 09h, and 07h. (CVBS)
- Bit 0** Bit 10 of the CRT vertical retrace start. The lower bit [9:0] are defined in CRTC register index 10h and 07h. (CVRS)

CRT31: Interlace Retrace

Read/Write Address: 3?5h, Index: 31h
Power-on Default: 00h

This register specifies when vertical retrace begins. This register is only valid if interlace mode is enabled (CRT30 Bit 7 = 1).

7	6	5	4	3	2	1	0
SPECIFY # CHARACTER UNITS IN HORIZONTAL TIMING							

- Bit 7:0** Specify the number of character units in horizontal timing when vertical retrace begins.

CRT32: TV Vertical Display Enable Start

Read/Write Address: 3?5h, Index: 32h
Power-on Default: 00h

This register specifies the vertical display enable start for TV timing.

7	6	5	4	3	2	1	0
TV VERTICAL DISPLAY ENABLE							

Bit 7:0 When CRT vertical count = CRT32 [7:0], TV vertical display enable become active.

CRT33: TV Vertical Display Enable End - High

Read/Write Address: 3?5h, Index: 33h
Power-on Default: 00h

This register specifies the vertical display enable end for TV timing. This register is a 11-bit register. The lower 8-bit of this register resides in CRT34.

7	6	5	4	3	2	1	0
ITE	HBE		VBE		CRT VERTICAL COUNT		

Bit 7 Interlace Timing Enable for double scan modes (i.e.: mode 13, etc.) (ITE)
0 = Disable
1 = Enable

Bit 6:5 Bit [7:6] of Horizontal Blank End. Bit 5 is located in bit 7 of CRTC register, 3?5h, index 5. Bit [4:0] is located in CRTC register, 3?5h, index 3. (HBE)

Bit 4:3 Bit [9:8] of Vertical Blank End. Bit [7:0] of Vertical Blank End is located in CRTC register, 3?5h, index 16. (VBE)

Bit 2:0 When CRT vertical count = {CRT33 [2:0], CRT34 [7:0]}, TV vertical display enable becomes inactive.

CRT34: TV Vertical Display Enable End - Low

Read/Write Address: 3?5h, Index: 34h
Power-on Default: 00h

This register specifies the vertical display enable end for TV timing.

7	6	5	4	3	2	1	0
CRT VERTICAL COUNT							

Bit 7:0 When CRT vertical count = {CRT33 [2:0], CRT34 [7:0]} TV vertical display enable becomes inactive.

CRT35: Vertical Screen Expansion DDA Control Constant - Low

Read/Write Address: 3?5h, Index: 35h
Power-on Default: 00h

This register specifies bit [7:0] the DDA control constant (DDACC) which is used for vertical screen expansion in VGA modes. Bit [9:8] of the DDACC is located in CRT36.

To enable vertical screen expansion in VGA graphics modes, one needs to program the DDA control constant (DDACC) equal to:

$$DDACC = \frac{1024 * \text{actual vertical size}}{\text{expanded vertical size}}$$

To enable vertical expansion in VGA text mode, one must program DDACC [2:0] = # of times the last character row should be repeated.

7	6	5	4	3	2	1	0
VERTICAL SCREEN EXPANSION							

Bit 7:0 This register defines the lower 8 bits of the vertical screen expansion DDA control constant. The upper 2 bits of the DDACC register is located in CRT36. For VGA text modes, only the lower [2:0] are valid.

CRT36: Vertical Screen Expansion DDA Control Constant - High

Read/Write Address: 3?5h, Index: 36h
Power-on Default: 00h

This register the vertical screen expansion DDA control constant lower 8 bits.

7	6	5	4	3	2	1	0
RESERVED						VSE	

Bit 7:2 Reserved

Bit 1:0 This register defines bit [9:8] of the vertical screen expansion DDA control constant. The lower 8-bit are located in CRT35. (VSE)

CRT37: Hardware/VGA Test Selection

Read/Write Address: 3?5h, Index: 37h
Power-on Default: 00h

7	6	5	4	3	2	1	0
HARDWARE TEST				VGA HARDWARE TEST SELECTION			

Bit 7:5 Reserved for hardware test bus selection

Bit 4:0 Reserved for VGA hardware testing

CRT38: TV Equalization Pulse Control - *For use with an external TV encoder only*

Read/Write Address: 3?5h, Index: 38h
Power-on Default: 00h

7	6	5	4	3	2	1	0
CSS	R	EQUALIZATION PULSE WIDTH					

Bit 7 Composite Sync Select (CSS)
 0 = CSYNC is generated by SYNCs (HSYNC NOR VSYNC)
 1 = CSYNC is generated by equalizer state machine

Bit 6 Reserved (R)

Bit 5:0 Equalization pulse width in units of four VCLK

CRT39: TV Serration Pulse Control - *For use with an external TV encoder only*

Read/Write Address: 3?5h, Index: 39h

Power-on Default: 00h

7	6	5	4	3	2	1	0
RESERVED		SERRATION PULSE WIDTH					

Bit 7:6 Reserved

Bit 5:0 Serration pulse width in units of four VCLK

CRT3A: TV Total Timing Control for the Internal TV Encoder

Read/Write Address: 3?5h, Index: 3Ah

Power-on Default: 00h

7	6	5	4	3	2	1	0
RESERVED		HSYNC			DOT CLOCKS		

Bit 7:6 Reserved

Bit 5:3 00 = Normal
 01 = HSYNC delayed by one pixel clock
 02 = HSYNC delayed by two pixel clock
 03 = HSYNC delayed by three pixel clock
 04 = HSYNC delayed by four pixel clock
 05 = HSYNC delayed by five pixel clock

Bit 2:0 07 = One character clock contains 7 dot clocks
 06 = One character clock contains 6 dot clocks
 05 = One character clock contains 5 dot clocks
 04 = One character clock contains 4 dot clocks
 03 = One character clock contains 3 dot clocks

02 = One character clock contains 2 dot clocks

01 = One character clock contains 1 dot clocks

00 = One character clock contains 0 dot clocks

For example, to program 910 pixel horizontal total for 4fc NTSC TV mode:

Program CRT horizontal total register to be 109 character clock

Program 3?4 index 3A bit [2:0] = 06

The actual total number of characters per horizontal line is $109 + 5 = 114$

The horizontal total in pixel clock is: $113 \times 8 + 6 = 910$

CRT3B: Miscellaneous Lock Register I

Read/Write Address: 3?5h, Index: 3Bh

Power-on Default: 00h

7	6	5	4	3	2	1	0
RESERVED FOR VGA HARDWARE TESTING							

Bit 7:0 Reserved for VGA Hardware testing

CRT3C: Miscellaneous Lock Register II

Read/Write Address: 3?5h, Index: 3Ch

Power-on Default: 00h

7	6	5	4	3	2	1	0
RESERVED		BSS	VGALC	RESERVED			

Bit 7:6 Reserved VGA hardware debug test bus selection

Bit 5 Blanking signal selection (BSS)

0 = The blanking signal sent to RAMDAC is reversed active display. Outside of active display the blanking is active (black color). The border color register has no effect.

1 = The blank signal sent to RAMDAC is the normal blank signal from CRT. When both the blank and dispen are inactive the border color is displayed.

Bit 4 VGA line compare register (CRT09 [6] and CRT07 [4]) force (VGALC)

0 = normal (default)

1 = Enable. Force line compare [9:8] to be high. The original line compare control bits [9:8] have no effect. This register is used for Japanese DOS hardware scrolling compatibility purpose.

Bit 3:0 Reserved

CRT3D Scratch Register Bits

Read/Write Address: 3?5h, Index: 3Dh

Power-on Default:

7	6	5	4	3	2	1	0
SCRATCH REGISTER BITS							

Bit 7:0 Scratch Register Bit

CRT3E: Scratch Register Bits

Read/Write Address: 3?4h, Index: 3Eh
Power-on Default: 00h

7	6	5	4	3	2	1	0
SCRATCH REGISTER BITS							

Bit 7:0 Scratch Register Bits

CRT3F: Scratch Register Bits

Read/Write Address: 3?4h, Index: 3Fh
Power-on Default: 00h

7	6	5	4	3	2	1	0
SCRATCH REGISTER BITS							

Bit 7:0 Scratch Register Bits

CRT9E: Expansion/Centering Control Register 2

Read/Write Address: 3?4h, Index: 9Eh
Power-on Default: 00h

7	6	5	4	3	2	1	0
FE	HSCRT	HSRW	VE	VC	VEE	VCE	HCE

Bit 7 Font expansion control bit (FE)
This bit is effective if the following is true: CRT9E_[4] = 0 and the text mode plus the vertical expansion is on and CRT09_[4:0] < H0F
0 = The font vertical expansion will repeat the last character row
1 = The font vertical expansion will insert lines (with screen background color) between the last scan line of the current character row and the first scan of the next character row.

Bit 6 Horizontal shadow register selection for CRT timing control (HSCRT)
0 = There are two sets of horizontal shadow registers (primary and secondary). The selection switch is at the beginning of the vsync. If CR9F_[0] or CR9F [1] or FPR32_[0] is equal to 1 the second set is selected. If these registers are not equal to 1 then the primary set is selected.

1 = To force the selection of the second set of horizontal shadow register

Bit 5 Horizontal shadow register read/write selection (HSRW)

The following register update are effected

SVR40_[7:0] - Horizontal total shadow
 SVR41_[7:0] - Horizontal blank start shadow
 SVR42_[4:0] - Horizontal blank end shadow
 SVR44_[7] - Horizontal blank end bit 5 shadow
 CRT33_[6:5] - Horizontal blank end bit 7 & 6
 SVR43_[7:0] - Horizontal sync start shadow
 SVR44_[4:0] - Horizontal sync end
 CRT9F_[0] - 10 dots expansion
 CRT9F_[1] - 12 dots expansion

These registers have two sets - primary and secondary.

Bit 5=0: The primary registers are selected for W/R and control crt

Bit 5=1: The secondary registers are selected for W/R and control crt

Bit 4 Vertical expansion DDA value selection (VE)

0 = Vertical expansion will select the DDA value from the DDA look up table (3?4.35&36). This bit has no effect if bit 2 of this register = 0.

1 = Vertical expansion will select the DDA value from the DDA look up table (3?4.90-91B).

Bit 3 Vertical centering offset value selection (VC)

0 = Select vertical centering offset value from vertical center offset register (3?4, Index A6). This bit has no effect if bit 1 of this register = 0

1 = Select vertical centering offset value from a look-up table (look up by vdispend)

Bit 2 Vertical expansion enable selection (VEE)

0 = Vertical expansion disable

1 = Vertical expansion enable

Bit 1 Vertical centering enable selection (VCE)

0 = Vertical centering disable

1 = Vertical centering enable

Bit 0 Horizontal centering enable selection (HCE)

0 = Horizontal centering disable

1 = Horizontal centering enable

CRT9F: Expansion/Center Control Register 1

Read/Write Address: 3?4h, Index: 9Fh

Power-on Default: 00h

7	6	5	4	3	2	1	0
RESERVED				HT	16DOT	CC12	CC10

- Bit 7:4** Reserved
- Bit 3** For hardware testing only (HT)
0 = VGA mode use non divide by 2 video clock. Extended VGA mode use divide by 2 video clock
1 = Reserved for 16 dot expansion. Should set to 0.
- Bit 2** Reserved for 16 dot expansion. Should set to 0. (16DOT)
- Bit 1** 12 dot expansion (CC12)
0 = 12 dots expansion disabled
1 = Character clock expand to 12 dots regardless of bit 0 of this register
- Bit 0** 10 dot expansion (CC10)
0 = 10 dots expansion
1 = Character clock expand to 10 dots

CRT90-9B Vertical DDA Look Up Table & CRTA0-A5: Vertical Centering Offset Look Up Table

Read/Write Address: 3?4, Index A0h-A5h
Power-on Default: 00h

3?4.90								3?4.91								3?4.A0					
7	6	5	4	3	2	1	0	7	6	5	4	3	2	1	0	5	4	3	2	1	0
FIELD 3								FIELD 2								FIELD 1					

- Field 3: This field compared with Vdisp_end (3?4.12 bit_[7:2])
- Field 2: This field is selected DDA value if field 3 compares
- Field 1: This field is selected vertical centering offset value if field 3 compares. The actual offset value = 3?4.A0_[5:0] x 4

The vertical expansion/centering using look up table is enabled only if the following conditions are true: CR9E_[3:1] = 111; if the compare fails to match with any entry, the value from 3?4.A6 will be used for vertical centering and the 3?4.35&36 will be used for DDA.

The following register groups behave the same:

3?4.92; 3?4.93; 3?4.A1
3?4.94; 3?4.95; 3?4.A2
3?4.96; 3?4.97; 3?4.A3
3?4.98; 3?4.99; 3?4.A4
3?4.9A; 3?4.9B; 3?4.A5

CRTA0-A5: Vertical Centering Offset Look Up Table

Read/Write Address: 3?4, Index A0h-A5h
Power-on Default: 00h

3?4.90								3?4.91								3?4.A0					
7	6	5	4	3	2	1	0	7	6	5	4	3	2	1	0	5	4	3	2	1	0
FIELD 3								FIELD 2								FIELD 1					

Field 3: This field compared with Vdisp_end (3?4.12 bit_[7:2])

Field 2: This field is selected DDA value if field 3 compares

Field 1: This field is selected vertical centering offset value if field 3 compares. The actual offset value = 3?4.A0_[5:0] x 4

The vertical expansion/centering using look up table is enabled only if the following conditions are true: CR9E_[3:1] = 111; if the compare fails to match with any entry, the value from 3?4.A6 will be used for vertical centering and the 3?4.35&36 will be used for DDA.

The following register groups behave the same:

3?4.92; 3?4.93; 3?4.A1
 3?4.94; 3?4.95; 3?4.A2
 3?4.96; 3?4.97; 3?4.A3
 3?4.98; 3?4.99; 3?4.A4
 3?4.9A; 3?4.9B; 3?4.A5

CRTA6: Vertical Centering Offset Register

Read/Write Address: 3?4, Index: A6h

Power-on Default: 00h

7	6	5	4	3	2	1	0
RESERVED		LINE SHIFT DOWN					

Bit 7:6 Reserved

Bit 5:0 Specifies how many lines the screen image will shift down. This register will have no effect if 3?4.9E bit_[1]=1

CRTA7: Horizontal Centering Offset Register

Read/Write Address: 3?4h, Index: A7h

Power-on Default: 00h

7	6	5	4	3	2	1	0
R	CHARACTER UNIT SHIFT RIGHT						

Bit 7 Reserved (R)

Bit 6:0 Specifies how many character units the screen image will shift to the right. This register has no effect if $\text{BIT}_{[0]} = 0$.

0 = Use to specify how many character units the screen image will shift to the right to center position. The horizontal screen centering look up table has no effect.

1 = To enable horizontal shift look up table ($\text{CRT9E}_{[0]}$ has to be 1). One of the table entry will be select and the value in the entry specifies how many character units the screen image will shift to the right center position.

The selection of the look up is as follows:

IF $\text{CRT01}_{[7:1]} = \text{CRTA8}_{[6:0]}$ control screen centering. Else if $\text{CRT01}_{[7:1]} = \text{CRTAA}_{[6:0]}$, $\text{CRTAB}_{[6:0]}$ control screen centering. Else if $\text{CRT01}_{[7:1]} = \text{CRTAC}_{[6:0]}$, $\text{CRTAD}_{[6:0]}$ control screen centering. Else $\text{CRA7}_{[6:0]}$ will be used as default to control screen centering.

CRTA8-AD: Horizontal Screen Centering Look Up Table

Read/Write Address: 3[?]4, Index A8h-ADh

Power-on Default: 00h

7	6	5	4	3	2	1	0
R	HORIZONTAL SCREEN CENTERING LOOK UP TABLE						

Bit 7: Reserved

Bit 6:0 Horizontal Screen Centering Look Up Table

Shadow VGA Registers

The Shadow VGA Registers are designed to control CRT, LCD and TV timing, and maintain VGA compatibility. Lynx3DM shadows 12 VGA CRT registers. When these shadow registers are unlocked, the CPU I/O write operation can write into both standard CRT registers and shadow registers through standard VGA CRTC I/O location. When these shadow registers are locked, the CPU I/O write can only write into the standard CRT registers through CRTC I/O location. These 12 shadow registers also have specific I/O location which is not controlled by Shadow Lock/Unlock Register.

SVR40 - Horizontal Total	SVR45 - Vertical Total	SVR4A - Overflow (bit 7, 6,5, 3, 2, 1, and 0)
SVR41 - Start Horizontal Blanking	SVR46 - Start Vertical Blank	SVR4B - Maximum Scan Line (bit 5 only)
SVR42 - End Horizontal Blanking	SVR47 - End Vertical Blank	SVR4C - Horizontal Display End
SVR43 - Start Horizontal Retrace	SVR48 - Vertical Retrace Start	SVR4D - Vertical Display End
SVR44 - End Horizontal Retrace	SVR49 - Vertical Retrace End	

Automatic Lock/Unlock Scheme for Shadow Registers

There are two ways to access shadow registers. One is through standard VGA CRT I/O location when CRT is the only selected display. These VGA CRT I/O write operations will write to both standard VGA CRT registers and shadow registers. The other way to access shadow registers is through their dedicated I/O locations. The shadow registers can only be read through their dedicated I/O locations.

When LCD or TV display is selected, the shadow registers will be automatically locked. The VGA CRT I/O write operation will write only to the standard VGA CRT registers. The shadow registers have to be accessed from their dedicated I/O location. This approach will reduce programming difficulty and maintain VGA compatibility.

SVR40: Shadow VGA Horizontal Total

Read/Write Address: 3?5h, Index: 40h
Power-on Default: 00h

This register shadows VGA CRT Horizontal Total register.

7	6	5	4	3	2	1	0
SHADOW VGA HORIZONTAL TOTAL							

Bit 7:0 Defines the total character count minus 5 characters per horizontal scan line. This register only depends on the resolution of LCD, not the type of LCD.

SVR41: Shadow VGA Horizontal Blank Start

Read/Write Address: 3?5h, Index: 41h
Power-on Default: 00h

This register shadows VGA CRT Horizontal Blank Start register.

7	6	5	4	3	2	1	0
SHADOW VGA HORIZONTAL BLANK							

Bit 7:0 When the horizontal character = SVR41 [7:0], shadow VGA horizontal blank become active.

SVR42: Shadow VGA Horizontal Blank End

Read/Write Address: 3?5h, Index: 42h
Power-on Default: 00h

This register shadows VGA CRT Horizontal Blank End register.

7	6	5	4	3	2	1	0
R	SDES		SHADOW VGA HORIZONTAL BLANK INACTIVE				

Bit 7 Reserved (R)

Bit 6:5 Shadows display enable skew control (SDES)

Bit 4:0 When the horizontal character = {SVR44 [7],SVR42 [4:0]}, shadow VGA horizontal blank become inactive.

SVR43: Shadow VGA Horizontal Retrace Start

Read/Write Address: 3?5h, Index: 43h
Power-on Default: 00h

This register shadows VGA CRT Horizontal Retrace Start register.

7	6	5	4	3	2	1	0
SHADOW VGA HORIZONTAL RETRACE INACTIVE							

Bit 7:0 When the horizontal character = SVR43 [7:0], shadow VGA horizontal retrace become active.

SVR44: Shadow VGA Horizontal Retrace End

Read/Write Address: 3?5h, Index: 44h
Power-on Default: 00h

This register shadows VGA CRT Horizontal Retrace End register.

7	6	5	4	3	2	1	0
SVHB	SHRD		SHADOW VGA HORIZONTAL RETRACE INACTIVE				

Bit 7 When the horizontal character = {SVR44 [7],SVR41 [4:0]}, shadow VGA horizontal blank become inactive. (SVHB)

Bit 6:5 Shadows horizontal retrace delay (SHRD)

Bit 4:0 When the horizontal character = SVR44 [4:0], shadow VGA horizontal retrace become inactive.

SVR45: Shadow VGA Vertical Total

Read/Write Address: 3?5h, Index: 45h
Power-on Default: 00h

This register shadows VGA CRT Vertical Total register.

7	6	5	4	3	2	1	0
SHADOW VGA VERTICAL TOTAL							

Bit 7:0 Shadows the least significant 8 bits of 11 bits count of raster scan lines for display frame.

SVR46: Shadow VGA Vertical Blank Start

Read/Write Address: 3?5h, Index: 46h
Power-on Default: 00h

This register shadows VGA CRT Vertical Blank Start register.

7	6	5	4	3	2	1	0
SHADOW VGA VERTICAL BLANK START							

Bit 7:0 Shadows the least significant 8-bit of the 11-bit VGA CRT vertical blank start register.

SVR47: Shadow VGA Vertical Blank End

Read/Write Address: 3?5h, Index: 47h
Power-on Default: 00h

This register shadows VGA CRT Vertical Blank End register.

7	6	5	4	3	2	1	0
SHADOW VGA VERTICAL BLANK END							

Bit 7:0 Shadows the least significant 8-bit VGA CRT vertical blank end register.

SVR48: Shadow VGA Vertical Retrace Start

Read/Write Address: 3?5h, Index: 48h
Power-on Default: 00h

This register shadows VGA CRT Vertical Retrace Start register.

7	6	5	4	3	2	1	0
SHADOW VGA VERTICAL RETRACE START							

Bit 7:0 Shadows the least significant 8-bit of the 11-bit vertical retrace start register.

SVR49: Shadow VGA Vertical Retrace End

Read/Write Address: 3?5h, Index: 49h
Power-on Default: 00h

This register shadows VGA CRT Vertical Retrace End register.

7	6	5	4	3	2	1	0
RESERVED				SHADOW VGA/CRT VERTICAL RETRACE			

Bit 7:4 Reserved

Bit 3:0 Shadows bit [3:0] of VGA CRT vertical retrace end register.

SVR4A: Shadow VGA Vertical Overflow

Read/Write Address: 3?5h, Index: 4Ah

Power-on Default: 00h

This register shadows VGA CRT Vertical Overflow register.

7	6	5	4	3	2	1	0
SVRS9	SVDE9	SVTB9	R	SVBS	SVRS8	SVDE8	SVTB8

Bit 7 Shadows vertical retrace start bit 9 (SVRS9)

Bit 6 Shadow vertical display enable bit 9 (3?5h, index 7 [6]). When FPR33[5] = 1, can only access this bit through 3?5h, index 4Ah. (SVDE9)

Bit 5 Shadows vertical total bit 9 (SVTB9)

Bit 4 Reserved (R)

Bit 3 Shadows vertical blank start bit 8 (SVBS)

Bit 2 Shadows vertical retrace start bit 8 (SVRS8)

Bit 1 Shadow vertical display enable bit 8 (3?5h, index 7 [1]). When FPR33[5] = 1, can only access this bit through 3?5h, index 4Ah. (SVDE8)

Bit 0 Shadows vertical total bit 8 (SVTB8)

SVR4B: Shadow VGA Maximum Scan Line

Read/Write Address: 3?5h, Index: 4Bh

Power-on Default: 00h

This register shadows VGA CRT Maximum Scan Line register.

7	6	5	4	3	2	1	0
SSP		SVBS	RESERVED				

Bit 7:6 Shadow 3C2 bit_[7:6] for sync polarity (SSP)

Bit 5 Shadows vertical blank start bit 9 (SVBS)

Bit 4:0 Reserved

SVR4C: Shadow VGA Horizontal Display End

Read/Write Address: 3?5h, Index: 4Ch
Power-on Default: 00h

This register shadows VGA CRT Horizontal Display end.

7	6	5	4	3	2	1	0
SHADOW HORIZONTAL DISPLAY END							

Bit 7:0 Shadows Horizontal Display End register (3?5h, index 01). When FPR33[5] = 1, it locks access to this register only through 3?5h, index 4Ch.

SVR4D: Shadow VGA Vertical Display End

Read/Write Address: 3?5h, Index: 4Dh
Power-on Default: 00h

This register shadows VGA CRT Vertical Display end.

7	6	5	4	3	2	1	0
SHADOW VERTICAL DISPLAY END							

Bit 7:0 Shadows Vertical Display End register [7:0] (3?5h, index 12) When FPR33[5] = 1, it locks access to this register only through 3?5h, index 4Dh.

Chapter 22: 2D & Video Registers

Table 28: Memory Mapped Registers Quick Reference

Summary of Registers	Page
<i>Drawing Engine Control Registers</i>	
DPR00: Source Y or K2	22 -5
DPR02: Source X or K1	22-5
DPR04: Destination Y or Start Y	22-6
DPR06: Destination X or Start X	22-7
DPR08: Dimension Y or Error Term	22-7
DPR0A: Dimension X or Vector Length	22-8
DPR0C: ROP and Miscellaneous Control	22-8
DPR0E: Drawing Engine Commands and Control	22-10
DPR10: Source Row Pitch	22-11
DPR12: Destination Row Pitch	22-12
DPR14: Foreground Colors	22-12
DPR18: Background Colors	22-13
DPR1C: Stretch Source Height Y	22-14
DPR1E: Drawing Engine Data Format and Location Format Select	22-14
DPR20: Color Compare	22-15
DPR24: Color Compare Masks	22-16
DPR28: Bit Mask	22-16
DPR2A: Byte Mask Enable	22-17
DPR2C: Scissors Left and Control	22-17
DPR2E: Scissors Top	22-18
DPR30: Scissors Right	22-18
DPR32: Scissors Bottom	22-18
DPR34: Mono Pattern Low	22-19
DPR38: Mono Pattern High	22-19
DPR3C: XY Addressing Destination & Source Window Widths	22-19
DPR40: Source Base Address	22-20
DPR44: Destination Base Address	22-20

Summary of Registers (Continued)	Page
<i>Video Processor Control Registers</i>	
VPR00: Miscellaneous Graphics and Video Control	22-21
VPR04: Color Keys	22-23
VPR08: Color Key Masks	22-24
VPR0C: Data Source Start Address for Extended Graphics Modes	22-25
VPR10: Data Source Width and Offset for Extended Graphics Modes	22-25
VPR14: Video Window I Left and Top Boundaries	22-25
VPR18: Video Window I Right and Bottom Boundaries	22-26
VPR1C: Video Window I Source Start Address	22-26
VPR20: Video Window I Source Width and Offset	22-27
VPR24: Video Window I Stretch Factor:	22-27
VPR2C: Video Window II Right and Bottom Boundaries	22-28
VPR30: Video Window II Source Start Address	22-29
VPR34: Video Window II Source Width and Offset	22-29
VPR38: Video Window II Stretch Factor	22-29
CPR00: Capture Port Control	22-45
VPR40: Graphic Scale Factor	22-31
VPR44: Graphic Data Source Starting Address for Odd Field	22-32
VPR48: Video Window I Chroma Data Source Starting Address	22-32
VPR4C: Video Window II Chroma Data Source Starting Address	22-32
VPR50: Sub-Picture Data Source Starting Address	22-33
VPR54: FIFO Priority Control	22-33
VPR58: FIFO Empty Request level Control	22-35
VPR5C: YUV to RGB Conversion Constant	22-36
VPR60: Current Scan Line Position	22-37
VPR64: Signature Analyzer Control and Status	22-37
VPR70: Sub Picture Color Look Up Register 0	22-38
VPR74: Sub Picture Color Look Up Register 1	22-38
VPR78: Sub Picture Color Look Up Register 2	22-38
VPR7C: Sub Picture Color Look Up Register 3	22-39
VPR80: Sub Picture Color Look Up Register 4	22-39
VPR84: Sub Picture Color Look Up Register 5	22-39
VPR88: Sub Picture Color Look Up Register 6	22-40
VPR8C: Sub Picture Color Look Up Register 7	22-40
VPR90: Sub Picture Color Look Up Register 8	22-40
VPR94: Sub Picture Color Look Up Register 9	22-41
VPR98: Sub Picture Color Look Up Register A	22-41

Summary of Registers (Continued)	Page
VPR9C: Sub Picture Color Look Up Register B	22-41
VPRA0: Sub Picture Color Look Up Register C	22-42
VPRA4: Sub Picture Color Look Up Register D	22-42
VPRA8: Sub Picture Color Look Up Register E	22-42
VPRAC: Sub Picture Color Look Up Register F	22-43
VPRB0: Sub Picture Top/Left Boundary	22-43
VPRB4: Sub Picture Bottom/Right Boundary	22-43
VPRB8: Sub Picture Source Data Address Offset and Line Width	22-44
VPRC0: Video Window I U/V Scale Factor	22-44
VPRC4: Video Window II Scale Factor	22-45
<i>Capture Processor Control Registers</i>	
CPR00: Capture Port Control	22-45
CPR04: Video Source Clipping Control	22-48
CPR08: Video Source Capture Size Control	22-48
CPR0C: Capture Port Buffer I Source Start Address	22-49
CPR10: Capture Port Buffer II Source Start Address	22-49
CPR14: Capture Port Source Offset Address	22-49
CPR18: Capture FIFO Empty Request level Control	22-50

Note: Some VPR registers can be accessed using memory mapped register space, or can be accessed using I/O mapped register space. Please see register descriptions for detailed information.

The drawing processor and video processor registers are all memory mapped. The following diagram illustrates the memory mapped register address assignment.

	2D3D Reg Port	2K	0000_0000 - 0000_07ff
	Video Reg Port	2K	0000_0800 - 0000_0fff
	Vidcap Reg Port	2K	0000_1000 - 0000_17ff
	MC ICMD Reg Port	2K	0000_1800 - 0000_1fff
	MD IDCT Reg Port	2K	0000_2000 - 0000_27ff
	Mas Mif Reg Port	2K	0000_2800 - 0000_2fff
	2D3D Master Reg Port	2K	0000_3000 - 0000_37ff
	MC Core Reg Port	2K	0000_3800 - 0000_3fff
	MC ICMD Data Port	2K	0000_4000 - 0000_47ff
	MC IDCT Data Port	2K	0000_4800 - 0000_4fff
	Mas Mif Data Port	2K	0000_5000 - 0000_57ff
	// not used //	2K	0000_5800 - 0000_5fff
	2D3D Data Port	8K	0000_6000 - 0000_7fff
	// not used //	712K	0000_8000 - 000b_ffff
	Memory Map IO Space	256K	000c_0000 - 000f_ffff
	Additional DE Data Port	1MB	0010_0000 - 001f_ffff
FB Space	30MB Frame Buffer	30MB	0020_0000 - 01ff_ffff

Figure 47: Memory Mapped Address Diagram

Drawing Engine Control Registers

The Drawing Engine supports various drawing functions, including Bresenham line draw, short stroke line draw, BITBLT, rectangle fill, HOSTBLT, Rotation Blit, and others. Hardware clipping is supported by 4 registers, DPR2C-DPR32, which defines a rectangular clipping area.

The drawing engine supports two types of format for its source and destination locations. One can specifies location format in X-Y coordinate, where the upper left corner of the screen is defined to be (0,0); this method is referred as X-Y addressing. Also, one can specify the location format based on its position in the display memory sequentially from the first pixel of the visible data; this method is referred as DE linear addressing. To select DE linear addressing, one must set DPR1E bit [3:0] = 1111.

All Drawing Engine control registers can be accessed via memory-mapped.

DPR00: Source Y or K2

Read/Write Address: DP_Base+00h

Power-on Default: Undefined

This register specifies the 12-bit Source Y position in x-y addressing mode, or low-order source address in DE linear addressing mode (when DPR1E bit [3:0] = 11xxb). This register is also used to specify the 14-bit for K2 constant of Bresenham line when DPR0E bit [3:0] = 0111b to select Bresenham line command function.

15	14	13	12	11	10	9	8	7	6	5	4	3	2	1	0
RESERVED		SOURCE Y FOR X-Y ADDRESSING													

Bit 15:14 Reserved

Bit 13:0 Source Y for X-Y addressing. In 24-bit packed modes, Source Y needs to be multiplied by 3.
OR
High-order source address SA[23:12] for DE linear addressing. Low-order 12-bit are in DPR02.

Bresenham Line (DPR0E bit [3:0] = 0111b)

15	14	13	12	11	10	9	8	7	6	5	4	3	2	1	0
RESERVED		AXIAL DIAGONAL CONSTANT (K2)													

Bit 15:14 Reserved**Bit 13:0** Axial Diagonal Constant (K2) = $2 * (\min(|dx|, |dy|) - \max(|dx|, |dy|))$ **DPR02: Source X or K1**

Read/Write Address: DP_Base+02h

Power-on Default: Undefined

This register specifies the 12-bit Source X position in x-y addressing mode, or low-order source address in linear addressing mode (when DPR1E bit [3:0] = 11xxb). This register is also used to specify the 14-bit for K1 constant of Bresenham line when DPR0E bit [3:0] = 0111b to select Bresenham line command function. For HOSTBLT write command function (when DPR0E bit [3:0] = 1000b), this register is also used to specify the 3-bit HOST mono source for alignment.

15	14	13	12	11	10	9	8	7	6	5	4	3	2	1	0
RESERVED				SOURCE X FOR X-Y ADDRESSING											

Bit 12:15 Reserved

Bit 11:0 Source X for X-Y addressing mode. In 24-bit packed modes, Source X needs to be multiplied by 3.
OR
Low-order source address SA [11:0] for DE linear addressing mode. Higher order 12-bit are in DPR00.

Note: For 24-bit color pattern, $Xs = (PatXs * 3) \text{ LOGIC_OR } (Yd[2:0] * 3, \text{ shift } 3 \text{ bits to left})$
 For 32-bit color pattern, $Xs = (PatXs) \text{ LOGIC_OR } (Yd[2:0], \text{ shift } 3 \text{ bits to left})$

Bresenham Line (DPR0E bit [3:0] = 0111b)

15	14	13	12	11	10	9	8	7	6	5	4	3	2	1	0
RESERVED		AXIAL STEP CONSTANT K1													

Bit 15:14 Reserved

Bit 13:0 Axial Step Constant ($K1 = 2 * \min(|dx|, |dy|)$)

HOSTBLT Write (DPR0E bit [3:0] = 1000b)

15	14	13	12	11	10	9	8	7	6	5	4	3	2	1	0
RESERVED													HMSA		

Bit 15:3 Reserved

Bit 2:0 Host mono source alignment for 8, 16, or 32-bit color modes. For 24-bit color mode, software needs to adjust for alignment. (HMSA)

DPR04: Destination Y or Start Y

Read/Write Address: DP_Base+04h
 Power-on Default: Undefined

This register specifies the 12-bit Destination Y position in x-y addressing mode or higher-order destination address for DE linear addressing mode (when DPR1E bit [3:0] = 11xxb). This register is also used to specify Vector Y start address for Bresenham Line when DPR0E bit [3:0] = 0111b to select Bresenham line command function.

15	14	13	12	11	10	9	8	7	6	5	4	3	2	1	0
RESERVED		DESTINATION Y OR START Y													

Bit 15:14 Reserved

Bit 13:0 Destination Y for X-Y addressing. In 24-bit packed modes, Destination Y needs to be multiplied by 3.
 OR
 High-order 12 bits destination address DA[23:12] for DE linear addressing.

Bresenham Line (DPR0E bit [3:0] = 0111b)
 Vector Y start address

DPR06: Destination X or Start X

Read/Write Address: DP_Base+06h

Power-on Default: Undefined

This register specifies 12-bit Destination X position in x-y addressing mode or low-order 12-bit destination address in DE linear addressing mode (when DPR1E bit [3:0] = 11xxb). This register is also used to specify Vector X start address for Bresenham Line when DPR0E bit [3:0] = 0111b to select Bresenham line command function.

15	14	13	12	11	10	9	8	7	6	5	4	3	2	1	0
RESERVED				DESTINATION X OR START X											

Bit 15:12 Reserved**Bresenham Line (DPR0E bit [3:0] = 0111b)**

Bit 11:0 Destination X for X-Y addressing. In 24-bit packed modes, Destination X needs to be multiplied by 3.

Vector X start address

OR

Low-order 12 bits destination address

DA[11:0] for DE linear addressing.

DPR08: Dimension Y or Error Term

Read/Write Address: DP_Base+08h

Power-on Default: Undefined

This register specifies the rectangle height or Dimension Y in pixels. When Bresenham line command function is selected (DPR0E bit [3:0] = 0111b), this register specifies the Vector Error Term. When Short Stroke Line command function is selected (DPR0E bit [3:0] = 0110b), this register specifies the short stroke line length for non-horizontal short stroke line

15	14	13	12	11	10	9	8	7	6	5	4	3	2	1	0
RESERVED				DIMENSION Y OR ERROR TERM											

		Short Stroke (DPR0E bit [3:0] = 0110b)	Bresenham Line (DPR0E bit [3:0] = 0111b)
Bit 15:14	Reserved	Reserved	Reserved
Bit 13:12	Reserved	Reserved	Vector Error Term
Bit 11:0	Dimension Y	Short Stroke Length if not a horizontal line (≠ 0° or ≠ 180°)	(ET)*

* Vector Error Term is determined based on the following logic:

ET = 2 * min (|dx|,|dy|) - max (|dx|,|dy|) if starting X > ending X.

ET = 2 * min (|dx|,|dy|) - max (|dx|,|dy|) - 1 if starting X <= ending X.

- Bit 11** Enable Repeat Rotation BLT. This bit is only valid when DPR0E[3:0] = 1011b. (ERR)
0 = disable
1 = enable
- Bit 10** Matching Pixel Control. This bit is only valid when transparency is enabled (bit 8 of this register = 1) (MPC)
0 = Matching pixel is opaque
1 = Matching pixel is transparent
- Bit 9** Pixel Control Transparency Select (PCTS)
0 = Source controls transparency
1 = Destination controls transparency
- Bit 8** Transparency Enable (TE)
0 = disable
1 = enable
- Bit 7:4** ROP3 code¹ Reserved
- Bit 3:0** ROP3 code¹ ROP2 code²

Notes:

¹ 3 Operands 256 operations ROP codes table reference listed below. For details on ROP codes, please refer to the Microsoft's device driver adaptation guide.

ROP3 Code	Bit 7	Bit 6	Bit 5	Bit 4	Bit 3	Bit 2	Bit 1	Bit 0
Pattern	1	1	1	1	0	0	0	0
Source	1	1	0	0	1	1	0	0
Destination	1	0	1	0	1	0	1	0

² 2 Operands 16 operations ROP codes table listed below:

ROP2 Code	Bit 3	Bit 2	Bit 1	Bit 0
Zero	0	0	0	0
~(D+S)	0	0	0	1
D * ~S	0	0	1	0
~S	0	0	1	1
S * ~D	0	1	0	0
~D	0	1	0	1
D ⊕ S	0	1	1	0
~(D * S)	0	1	1	1

ROP2 Code	Bit 3	Bit 2	Bit 1	Bit 0
D * S	1	0	0	0
~(D ⊕ S)	1	0	0	1
D	1	0	1	0
D + ~S	1	0	1	1
S	1	1	0	0
S + ~D	1	1	0	1
D + S	1	1	1	0
One	1	1	1	1

DPR0E: Drawing Engine Commands and Control

Read/Write Address: DP_Base+0Eh

Power-on Default: Undefined (except for Bit 15 and Bit 12 = 0)

This register specifies the drawing engine command and control registers.

15	14	13	12	11	10	9	8	7	6	5	4	3	2	1	0
DEA	PS	DUE	DEQS	SSL	BMA	XYS		GSE	HBSC	PSB	DECE	COMMAND FUNCTIONS			

Bit 15 Drawing Engine Activate (DEA)
0 = Idle (Power-on default = 0)
1 = Start Activate Drawing Engine

Bit 14 Pattern Select (PS)
0 = mono pattern
1 = color pattern

Bit 13 Destination X Update Enable (DUE)

0 = Do not update destination X on completion of a drawing engine function
1 = Update destination X on completion of a drawing engine function

Bit 12 Drawing Engine Quick Start Enable. If this bit is set, drawing engine will be activated right after dimension X is provided. One does not need to activate the drawing engine by setting bit 15 = 1 if quick start is already enabled. (DEQS)
0 = disable (Power-on default = 0)
1 = enable

Bit 11 Direction for Short Stroke Line and BITBLT For diagonal and vertical line, this bit needs to be set to "0". (SSL)

Bit 11	Short Stroke Line Direction	BITBLT Direction
0	not horizontal	Left to Right
1	horizontal	Right to Left

Bit 10 Bresenham Major Axis (Y) (BMA)
0 = major axis is X
1 = major axis is Y. For vertical line, this bit needs to be set.

Bit 9:8 X-Step and Y-Step (XYS)
01 = Counter Clock Wise Rotate 90 degree (CCW90)
10 = Clock Wise Rotate 90 degree (CW90)
00 = Right_Top and Left_Bottom as axis flip
11 = Left_Top and Right_Bottom as axis flip

Bit 7 Graphics Stretch Enable (only for Y direction) (GSE)

0 = disable
1 = enable

- Bit 6** HOST BITBLT Source Color Select (HBSC)
0 = Source is color
1 = Source is monochrome
- Bit 5** Last Pixel Select for Bresenham line (PSB)
0 = Vector not draw last pixel
1 = Vector draw last pixel
- Bit 4** Drawing Engine Capture Enable (DECE)
0 = Normal Operation. No HOSTBLT capture operation.
1 = Enable HOSTBLT Read capture operation
- Bit 3:0** Command Functions
0000 = BITBLT
0001 = Rectangle Fill
0010 = Reserved
0011 = Trapezoid Pattern Fill
0100 = Reserved
0101 = Run Length Encoding (RLE) Strip Draw
0110 = Short Stroke
0111 = Bresenham Line Draw
1000 = Host BLT Write
1001 = Host BLT Read
1010 = Host BLT Write from Left_Bottom
1011 = Rotation BLT
1111 = 3D Operation
1100 = AGP HbitW (master mode)* - with texture master engine
1101 = Reserved
1110 = Reserved

DPR10: Source Row Pitch

Read/Write Address: DP_Base+10h
Power-on Default: Undefined

This register specifies the source row offset in pixel unit for 8/16/32-bit color modes. In 24-bit color mode, source row offset needs to be multiplied by 3.

15	14	13	12	11	10	9	8	7	6	5	4	3	2	1	0
RESERVED				SOURCE ROW OFFSET											

- Bit 15:12** Reserved
- Bit 11:0** Source Row Offset. In 24-bit color mode, source row offset needs to be multiplied by 3.

DPR12: Destination Row Pitch

Read/Write Address: DP_Base+12h

Power-on Default: Undefined

This register specifies the destination row offset in pixel unit for 8/16/32-bit color modes. In 24-bit color mode, destination row offset needs to be multiplied by 3.

15	14	13	12	11	10	9	8	7	6	5	4	3	2	1	0
RESERVED				DESTINATION ROW OFFSET											

Bit 15:12 Reserved**Bit 11:0** Destination Row Offset. In 24-bit color mode, destination row offset needs to be multiplied by 3.**DPR14: Foreground Colors**

Read/Write Address: DP_Base+14h

Power-on Default: Undefined

The register specifies the foreground graphics color for 8-bit color (DPR1E bit [5:4] = 00b), 16-bit color (DPR1E bit [5:4] = 01b), and 24-bit color (DPR1E bit [5:4] = 11b) modes.

8-bit color mode

31	29	28	27	26	25	24	23	22	21	20	19	18	17	16	15
RESERVED															
15	14	13	12	11	10	9	8	7	6	5	4	3	2	1	0
RESERVED								FOREGROUND COLOR							

16-bit color mode

31	30	29	28	27	26	25	24	23	22	21	20	19	18	17	16
RESERVED															
15	14	13	12	11	10	9	8	7	6	5	4	3	2	1	0
FOREGROUND COLOR HIGH BYTE								FOREGROUND COLOR LOW BYTE							

24-bit color mode

31	30	29	28	27	26	25	24	23	22	21	20	19	18	17	16
RESERVED								FOREGROUND COLOR RED							
15	14	13	12	11	10	9	8	7	6	5	4	3	2	1	0
FOREGROUND COLOR GREEN								FOREGROUND COLOR BLUE							

Bit 31:24 Reserved

	<u>8-bit color mode</u>	<u>16-bit color mode</u>	<u>24-bit color mode</u>
Bit 23:16	Reserved	Reserved	Foreground Color Red
Bit 15:8	Reserved	Foreground Color High Byte	Foreground Color Green
Bit 7:0	Foreground Color 8-bit index	Foreground Color Low Byte	Foreground Color Blue

DPR18: Background Colors

Read/Write Address: DP_Base+18h
Power-on Default: Undefined

The register specifies the background graphics color for 8-bit color (DPR1E bit [5:4] = 00), 16-bit color (DPR1E bit [5:4] = 01), and 24-bit color (DPR1E bit [5:4] = 11) modes.

Note: in monochrome transparency mode (font operation), the background color needs to be programmed to equal to the invert of foreground color in DPR14.

8-bit color mode

31	30	29	28	27	26	25	24	23	22	21	20	19	18	17	16
RESERVED															
15	14	13	12	11	10	9	8	7	6	5	4	3	2	1	0
RESERVED								BACKGROUND COLOR							

16-bit color mode

31	30	29	28	27	26	25	24	23	22	21	20	19	18	17	16
RESERVED															
15	14	13	12	11	10	9	8	7	6	5	4	3	2	1	0
BACKGROUND COLOR HIGH BYTE								BACKGROUND COLOR GREEN							

24-bit color mode

31	30	29	28	27	26	25	24	23	22	21	20	19	18	17	16
RESERVED								BACKGROUND COLOR RED							
15	14	13	12	11	10	9	8	7	6	5	4	3	2	1	0
BACKGROUND COLOR GREEN								BACKGROUND COLOR BLUE							

Bit 31:24 Reserved

	<u>8-bit color mode</u>	<u>16-bit color mode</u>	<u>24-bit color mode</u>
Bit 23:16	Reserved	Reserved	Background Color Red
Bit 15:8	Reserved	Background Color High Byte	Background Color Green
Bit 7:0	Background Color	Background Color Low Byte	Background Color Blue

8-bit index

DPR1C: Stretch Source Height YRead/Write Address: DP_Base+1Ch
Power-on Default: Undefined

This register specifies the height of source block for stretch BITBLT.

15	14	13	12	11	10	9	8	7	6	5	4	3	2	1	0
RESERVED				SOURCE Y DIMENSION FOR STRETCH BLT											

Bit 15:12 Reserved**Bit 11:0** Source Y dimension for stretch BLT. (only for Y direction)**DPR1E: Drawing Engine Data Format and Location Format Select**Read/Write Address: DP_Base+1Eh
Power-on Default: Undefined

The register specifies drawing engine source & destination locations select and data format.

15	14	13	12	11	10	9	8	7	6	5	4	3	2	1	0
R	XY	PATTERN START Y			PATTERN START X				R	DEDF		DRAWING ENG LOCATION			

Bit 15 Reserved (R)

Bit 14 Pattern XY Overwrite Select (XY)
 0 = Normal. Drawing Engine uses Bit [13:8] as pattern address only when it is in linear addressing mode (Bit [3:0] = 1111b)
 1 = Overwrite. Drawing Engine uses Bit [13:8] as pattern address no matter what addressing mode it is in.

Bit 13:11 Pattern Start Y Address (Yd [2:0]). This address is only valid if Bit 14 = 1 or Bit [3:0] = 11xxb (linear addressing).

Bit 10:7 Pattern Start X Address (Xd [2:0]). This address is only valid if Bit 14 = 1 or Bit [3:0] = 11xxb (linear addressing). It is based on the top left corner of screen as (0,0) coordinate address. Rotation is needed for pattern source if Xd is non-zero. All 4 bits (bit 10:7) are used at 24bpp. Only 3 bits (bit 9:7) are used at 8, 16, and 32 bpp.

Bit 6 Reserved

Bit 5:4 Drawing Engine Data Format (DEDF)
 00 = 8-bit per pixel
 01 = 16-bit per pixel

10 = 32-bit per pixel
11 = 24-bit per pixel (24-bit packed)

Bit 3:0 Drawing Engine Locations (Source and Destination) Format Select. The drawing engine supports two types of format for its source and destination locations. One can specifies location format in X-Y coordinate, where the upper left corner of the screen is defined to be (0,0); this method is referred as X-Y addressing. Also, one can specifies the location format based on its position in the display memory sequentially from the first pixel of the visible data; this method is referred as DE linear addressing. This register selects the pixel width for X-Y addressing and DE linear addressing.
1111 = DE linear addressing
else = XY screen width depends on DPR3C register

DPR20: Color Compare

Read/Write Address: DP_Base+20h
Power-on Default: Undefined

The register specifies the color compare for 8-bit color (DPR1E bit [5:4] = 00), 16-bit color (DPR1E bit [5:4] = 01), and 24-bit color (DPR1E bit [5:4] = 11) modes.

Note, in monochrome transparency mode for font operations, the color compare needs to be programmed to equal to the foreground color in DPR14.

8-bit color mode

31	30	29	28	27	26	25	24	23	22	21	20	19	18	17	16
RESERVED															
15	14	13	12	11	10	9	8	7	6	5	4	3	2	1	0
RESERVED								COLOR COMPARE 8-BIT INDEX							

16-bit color mode

31	30	29	28	27	26	25	24	23	22	21	20	19	18	17	16
RESERVED															
15	14	13	12	11	10	9	8	7	6	5	4	3	2	1	0
COLOR COMPARE HIGH BYTE								COLOR COMPARE LOW BYTE							

24-bit color mode

31	30	29	28	27	26	25	24	23	22	21	20	19	18	17	16
RESERVED								COLOR COMPARE RED							
15	14	13	12	11	10	9	8	7	6	5	4	3	2	1	0
COLOR COMPARE GREEN								COLOR COMPARE BLUE							

	<u>8-bit color mode</u>	<u>16-bit color mode</u>	<u>24-bit color mode</u>
Bit 31:24	Reserved	Reserved	Reserved
Bit 23:16	Reserved	Reserved	Color Compare Red
Bit 15:8	Reserved	Color Compare High Byte	Color Compare Green

Bit 7:0 Color Compare 8-bit index Color Compare Low Byte Color Compare Blue**DPR24: Color Compare Masks**

Read/Write Address: DP_Base+24h

Power-on Default: Undefined

The register specifies the color compare mask for 8-bit color (DPR1E bit [5:4] = 00), 16-bit color (DPR1E bit [5:4] = 01), and 24-bit color (DPR1E bit [5:4] = 11) modes.

8-bit color mode

31	30	29	28	27	26	25	24	23	22	21	20	19	18	17	16
RESERVED															
15	14	13	12	11	10	9	8	7	6	5	4	3	2	1	0
RESERVED								COLOR COMPARE 8-BIT INDEX							

16-bit color mode

31	30	29	28	27	26	25	24	23	22	21	20	19	18	17	16
RESERVED															
15	14	13	12	11	10	9	8	7	6	5	4	3	2	1	0
COLOR COMPARE MASK HIGH BYTE								COLOR COMPARE MASK LOW BYTE							

24-bit color mode

31	30	29	28	27	26	25	24	23	22	21	20	19	18	17	16
RESERVED								COLOR COMPARE MASK RED							
15	14	13	12	11	10	9	8	7	6	5	4	3	2	1	0
COLOR COMPARE MASK GREEN								COLOR COMPARE MASK BLUE							

	<u>8-bit color mode</u>	<u>16-bit color mode</u>	<u>24-bit color mode</u>
Bit 31:24	Reserved	Reserved	Reserved
Bit 23:16	Reserved	Reserved	Color Compare Mask Red
Bit 15:8	<u>8-bit color mode</u> Reserved	<u>16-bit color mode</u> Color Compare Mask High Byte	<u>24-bit color mode</u> Color Compare Mask Green
Bit 7:0	Color Compare Mask 8-bit index	Color Compare Mask Low Byte	Color Compare Mask Blue

DPR28: Bit Mask

Read/Write Address: DP_Base+28h

Power-on Default: Undefined

The register specifies the Bit Mask for 8-bit color (DPR1E bit [5:4] = 00) and 16-bit color (DPR1E bit [5:4] = 01) modes.

8-bit color mode

15	14	13	12	11	10	9	8	7	6	5	4	3	2	1	0
RESERVED								BIT MASK 8-BIT INDEX							

16-bit color mode

15	14	13	12	11	10	9	8	7	6	5	4	3	2	1	0
BIT MASK HIGH BYTE								BIT MASK LOW BYTE							

	<u>8-bit color mode</u>	<u>16-bit color mode</u>
Bit 15:8	Reserved	Bit Mask High Byte
Bit 7:0	Bit Mask 8-bit index	Bit Mask Low Byte

DPR2A: Byte Mask Enable

Read/Write Address: DP_Base+2Ah
Power-on Default: Undefined

The register specifies the byte mask enable register for 64-bit datapath.

15	14	13	12	11	10	9	8	7	6	5	4	3	2	1	0
RESERVED								BYTE MASK FOR 64-BIT DATAPATH							

Bit 15:8	Reserved
Bit 7:0	Byte Mask for 64-bit datapath. Each bit enables the corresponding byte data. 0 = disable write 1 = enable write

DPR2C: Scissors Left and Control

Read/Write Address: DP_Base+2Ch
Power-on Default: Undefined

The register specifies the Scissors left boundary and control registers.

15	14	13	12	11	10	9	8	7	6	5	4	3	2	1	0
RESERVED		SE	SBS	SCISSORS BOUNDARY LEFT											

Bit 15:14	Reserved
Bit 13	Scissors Enable (SE) 0 = disable

1 = enable

Bit 12 Scissors Boundary Select (SBS)
 0 = Write disable outside the Scissors boundary
 1 = Write disable inside the Scissors boundary

Bit 11:0 Scissors Boundary Left. In 24-bit color mode, the scissors boundary left position needs to be multiplied by 3.

DPR2E: Scissors Top

Read/Write Address: DP_Base+2Eh
 Power-on Default: Undefined

The register specifies the scissors top boundary.

15	14	13	12	11	10	9	8	7	6	5	4	3	2	1	0
RESERVED				SCISSORS BOUNDARY TOP											

Bit 15:12 Reserved

Bit 11:0 Scissors Boundary Top. In 24-bit color mode, the scissors boundary top position needs to be multiplied by 3.

DPR30: Scissors Right

Read/Write Address: DP_Base+30h
 Power-on Default: Undefined

The register specifies the right boundary.

15	14	13	12	11	10	9	8	7	6	5	4	3	2	1	0
RESERVED				SCISSORS BOUNDARY RIGHT											

Bit 15:12 Reserved

Bit 11:0 Scissors Boundary Right. In 24-bit color mode, the scissors boundary right position needs to be multiplied by 3.

DPR32: Scissors Bottom

Read/Write Address: DP_Base+32h
 Power-on Default: Undefined

The register specifies the bottom boundary.

15	14	13	12	11	10	9	8	7	6	5	4	3	2	1	0
RESERVED				SCISSORS BOUNDARY BOTTOM											

Bit 15:12 Reserved

Bit 11:0 Scissors Boundary Bottom. In 24-bit color mode, the scissors boundary bottom position = scissors boundary top position DPR2E [11:0] + height of the clipping window.

DPR34: Mono Pattern Low

Read/Write Address: DP_Base+34h

Power-on Default: Undefined

The register specifies the monochrome pattern lower double word. It is 32-bit access only. The higher 32-bit are in DPR38.

31	30	29	28	27	26	25	24	23	22	21	20	19	18	17	16
MONO PATTERN TOP 4 LINES															
15	14	13	12	11	10	9	8	7	6	5	4	3	2	1	0
MONO PATTERN TOP 4 LINES															

Bit 31:0 Mono pattern top 4 lines. Line 3 data is located in the most significant byte where as line 0 data is located in the least significant byte.

DPR38: Mono Pattern High

Read/Write Address: DP_Base+38h

Power-on Default: Undefined

The register specifies the monochrome pattern higher double word. It is 32-bit access only. The lower 32-bit are in DPR34.

31	30	29	28	27	26	25	24	23	22	21	20	19	18	17	16
MONO PATTERN LAST 4 LINES															
15	14	13	12	11	10	9	8	7	6	5	4	3	2	1	0
MONO PATTERN LAST 4 LINES															

Bit 31:0 Mono pattern last 4 lines. Line 7 data is located in the most significant byte where as line 4 data is located in the least significant byte.

DPR3C: XY Addressing Destination & Source Window Widths

Read/Write Address: DP_Base+3Ch

Power-on Default: Undefined

The register specifies the XY width for source and destination window.

31	30	29	28	27	26	25	24	23	22	21	20	19	18	17	16
RESERVED				DESTINATION WINDOW WIDTH IN PIXEL											
15	14	13	12	11	10	9	8	7	6	5	4	3	2	1	0
RESERVED				SOURCE WINDOW WIDTH IN PIXEL											

Bit 31:28 Reserved

Bit 27:16 Destination Window width in pixel for XY addressing mode (max. = 4096 pixel)

Bit 15:12 Reserved

Bit 11:0 Source Window width in pixel for XY addressing mode (max. = 4096 pixel)

DPR40: Source Base Address

Read/Write Address: DP_Base+40h

Power-on Default: Undefined

The register specifies the Source base address in 64-bit unit.

31	30	29	28	27	26	25	24	23	22	21	20	19	18	17	16
RESERVED												SOURCE BASE ADDRESS			
15	14	13	12	11	10	9	8	7	6	5	4	3	2	1	0
SOURCE BASE ADDRESS															

Bit 31:20 Reserved

Bit 19:0 Source Base address

DPR44: Destination Base Address

Read/Write Address: DP_Base+44h

Power-on Default: Undefined

The register specifies the destination base address in 64-bit unit.

31	30	29	28	27	26	25	24	23	22	21	20	19	18	17	16
RESERVED												DESTINATION BASE ADDRESS			
15	14	13	12	11	10	9	8	7	6	5	4	3	2	1	0
DESTINATION BASE ADDRESS															

Bit 31:20 Reserved

Bit 19:0 Destination Base address**Video Processor Control Registers**

Lynx3DM integrates a concurrent video processor. It can support 2 independent video windows using hardware scaling for any size of video windows at any location of the screen display. The Video Processor Control Registers specify the control registers for Video Processor. The Video Processor Control Registers can only be accessed through memory-mapped.

VPR00: Miscellaneous Graphics and Video Control

Read/Write Address: VP_Base+00h/3?5, Index c0, c1, c2, c3

Power-on Default: 00h

This register specifies the controls for graphics and video window I/II. (where x = don't care)

31	30	29	28	27	26	25	24	23	22	21	20	19	18	17	16
RESERVED				CKEII	ESD	FR	VVWI	FVIE	FRIM	VIE	CKEI	TVWS	GDF		
15	14	13	12	11	10	9	8	7	6	5	4	3	2	1	0
R	EVWII	EVW HII HR	VWII AE	VWIIIE	VWFII			R	EVWI	EVWIIH	VWIIAE	VWIIIE	VWIF		

Bit 31:28 Reserved**Bit 27** Color Key Enable for Video Window II (CKEII)

0 = Disable

1 = Enable

Bit 26 Enable separate data (graphics or video) to DAC/TV. This bit is used to implement "Dual View" in index color mode. This bit needs to also be set when enabling flicker reduction for TV display in VGA index-color mode. (ESD)

0 = Disable

1 = Enable

Bit 25 Enable V0FIFO to fetch 8-bit index color data to LCD BKEND in non-VGA mode. Normally, the 8-bit index color data is fetched by graphics FIFO in non-VGA mode. This bit is designed to enable flicker reduction on TV display in non-VGA, 8-bit index color mode. (FR)

0 = Disable

1 = Enable

Bit 24 Select video window I source start address same as video capture buffer start address. This bit is used to automatically display captured data on video window I without programming video window I source start address register (SVWI).

0 = Normal. Video window I source start address is from VPR1C register.

1 = Video window I source start address is equal to capture port buffer I source start address (VPR48) or capture port buffer II source start address (VPR4C). If single buffer is selected for video capture, video window I source start address is equal to capture port buffer I source address. If double buffer is selected for video capture and capture port buffer I is busy, video window I source start address is equal to capture port buffer II source address.

- Bit 23** Fixed Vertical Interpolation Enable. Scale factor is fixed to 80. (FVIE)
0 = Disable
1 = Enable
- Bit 22** Flicker Reduction in Interlace Modes for TV display. V1FIFO will be used together with the graphics FIFO for flicker reduction. Therefore, only one video Window is allowed for this feature to be enabled. (FRIM)
0 = Disable
1 = Enable
- Bit 21** Vertical Interpolation Enable. This bit can only be set when single window is enabled. (VIE)
0 = Disable (line duplication)
1 = Enable
- Bit 20** Color Key Enable for Video Window I (CKEI)
0 = Disable
1 = Enable
- Bit 19** Top Video Window Select (TVWS)
0 = video window I is on top
1 = video window II is on top
- Bit 18:16** Graphics Data Format (GDF)
000 = 8-bit index
001 = 15-bit 5-5-5 RGB
010 = 16-bit 5-6-5 RGB
011 = 32-bit x-8-8-8 RGB
100 = 24-bit 8-8-8 RGB (packed)
101 = 8-bit 3-3-2 RGB
11x = Reserved
- Bit 15** Reserved (R)
- Bit 14** Enable Video Window II data doubling. This bit is in 8-bit index color mode when the VCLK is larger than 85 MHz. The V1FIFO will shift out data every 2 VCLK. (EVWII)
0 = Disable
1 = Enable
- Bit 13** Enable Video Window II Horizontal Replication (EVWII HR)
0 = Disable (horizontal interpolation)
1 = Enable (pixel duplication)
- Bit 12** Video Window II YUV Averaging Enable. 2 YUV pixels will be averaged and the result will become single pixel. (VWII AE)
0 = Disable
1 = Enable
- Bit 11** Video Window II Enable (VWII E)
0 = Disable

1 = Enable

- Bit 10:8** Video Window II Format (VWFII)
 000 = 8-bit index
 001 = 15-bit 5-5-5 RGB
 010 = 16-bit 5-6-5 RGB
 011 = 32-bit x-8-8-8 RGB
 100 = 24-bit 8-8-8 RGB (packed)
 101 = 8-bit 3-3-2 RGB
 11x = YUV 4:2:2
- Bit 7** Reserved (R)
- Bit 6** Enable Video Window I data doubling. This bit is used in 8-bit index color mode when the VCLK is larger than 85 MHz. The VOFIFO will shift out data every 2 VCLK. (EVWI)
 0 = Disable
 1 = Enable
- Bit 5** Enable Video Window I Horizontal Replication (EVWIH)
 0 = Disable (horizontal interpolation)
 1 = Enable (pixel duplication)
- Bit 4** Video Window I YUV Averaging Enable. 2 YUV pixels will be averaged and the result will become single pixel. (VWIAE)
 0 = Disable
 1 = Enable
- Bit 3** Video Window I Enable (VWIE)
 0 = Disable
 1 = Enable
- Bit 2:0** Video Window I Format (VWIF)
 000 = 8-bit index
 001 = 15-bit 5-5-5 RGB
 010 = 16-bit 5-6-5 RGB
 011 = 32-bit x-8-8-8 RGB
 100 = 24-bit 8-8-8 RGB (packed)
 101 = 8-bit 3-3-2 RGB
 11x = YUV 4:2:2

VPR04: Color Keys

Read/Write Address: VP_Base+04h/3?5, Index c4, c5, c6, c7
 Power-on Default: Undefined

This register specifies color keys for the two video windows

8-bit color mode

31	30	29	28	27	26	25	24	23	22	21	20	19	18	17	16
RESERVED								VIDEO WINDOW II COLOR KEY INDEX							
15	14	13	12	11	10	9	8	7	6	5	4	3	2	1	0
RESERVED								VIDEO WINDOW I COLOR KEY INDEX							

16-bit color mode

31	30	29	28	27	26	25	24	23	22	21	20	19	18	17	16
VIDEO WINDOW II COLOR KEY [15:8]								VIDEO WINDOW II COLOR KEY [7:0]							
15	14	13	12	11	10	9	8	7	6	5	4	3	2	1	0
VIDEO WINDOW I COLOR KEY [15:8]								VIDEO WINDOW I COLOR KEY [7:0]							

	<u>8-bit color mode</u>	<u>16-bit color mode¹</u>
Bit 31:24	Reserved	Video Window II Color Key [15:8]
Bit 23:16	Video Window II Color Key Index	Video Window II Color Key [7:0]
Bit 15:8	Reserved	Video Window I Color Key [15:8]
Bit 7:0	Video Window I Color Key Index	Video Window I Color Key [7:0]

Note¹: for 24-bit or 32-bit color mode, software will need to repack the color key data into RGB - 5:6:5 (16-bit) format.

VPR08: Color Key Masks

Read/Write Address: VP_Base+08h/3?5h, Index c8, c9, ca, cb
Power-on Default: Undefined

This register specifies color key masks for the two video window.

31	30	29	28	27	26	25	24	23	22	21	20	19	18	17	16
VIDEO WINDOW II COLOR KEY MASK															
15	14	13	12	11	10	9	8	7	6	5	4	3	2	1	0
VIDEO WINDOW I COLOR KEY MASK															

Bit 31:16	Video Window II Color Key Mask 0 = Disable color mask 1 = Enable color mask
Bit 15:0	Video Window I Color Key Mask 0 = Disable color mask 1 = Enable color mask

VPR0C: Data Source Start Address for Extended Graphics Modes

Read/Write Address: VP_Base+0Ch/3?5h, Index cc, cd, ce, cf
Power-on Default: Undefined

This register specifies data source start address for extended graphics modes

31	30	29	28	27	26	25	24	23	22	21	20	19	18	17	16
GDSB	RESERVED									GDSSA					
15	14	13	12	11	10	9	8	7	6	5	4	3	2	1	0
GDSSA															

Bit 31 Graphic Data Status Bit (GDSB)

Bit 30:22 Reserved

Bit 21:0 Graphics Data Source Starting Address, in 64-bit segment (GDSSA)

VPR10: Data Source Width and Offset for Extended Graphics Modes

Read/Write Address: VP_Base+10h/3?5h, Index d0, d1, d2, d3
Power-on Default: Undefined

This register specifies data source data line width and offset address for extended graphics modes.

31	30	29	28	27	26	25	24	23	22	21	20	19	18	17	16
RESERVED						GRAPHICS DATA SOURCE DATA LINE									
15	14	13	12	11	10	9	8	7	6	5	4	3	2	1	0
RESERVED						GRAPHICS DATA START ADDRESS OFFSET									

Bit 31:26 Reserved

Bit 25:16 Graphics Data Source data line width, in 64-bit segment

Bit 15:10 Reserved

Bit 9:0 Graphics Data Start Address Offset, in 64-bit segment

VPR14: Video Window I Left and Top Boundaries

Read/Write Address: VP_Base+14h/3?5h, Index d4, d5, d6, d7
Power-on Default: Undefined

This register specifies left and top boundary for video window I.

31	30	29	28	27	26	25	24	23	22	21	20	19	18	17	16
RESERVED					VIDEO WINDOW I TOP BOUNDARY										
15	14	13	12	11	10	9	8	7	6	5	4	3	2	1	0
RESERVED					VIDEO WINDOW I LEFT BOUNDARY										

Bit 31:27 Reserved

Bit 26:16 Video window I, top boundary

Bit 15:11 Reserved

Bit 10:0 Video window I, left boundary

VPR18: Video Window I Right and Bottom Boundaries

Read/Write Address: VP_Base+18h/3?5h, Index d8, d9, da, db

Power-on Default: Undefined

This register specifies right and bottom boundary for video window I.

31	30	29	28	27	26	25	24	23	22	21	20	19	18	17	16
RESERVED					VIDEO WINDOW I BOTTOM BOUNDARY										
15	14	13	12	11	10	9	8	7	6	5	4	3	2	1	0
RESERVED					VIDEO WINDOW I RIGHT BOUNDARY										

Bit 31:27 Reserved

Bit 26:16 Video window I, bottom boundary

Bit 15:11 Reserved

Bit 10:0 Video window I, right boundary

VPR1C: Video Window I Source Start Address

Read/Write Address: VP_Base+1Ch/3?5h, Index dc, dd, de, df

Power-on Default: Undefined

This register specifies video start address for video window I.

31	30	29	28	27	26	25	24	23	22	21	20	19	18	17	16
VWIS	RESERVED									VWISS					
15	14	13	12	11	10	9	8	7	6	5	4	3	2	1	0
VWISS															

Bit 31 Video Window I Status Bit (VWIS)**Bit 30:22** Reserved**Bit 21:0** Video Window I source start address for, in 64-bit segment. (VWISS)

VPR20: Video Window I Source Width and Offset

Read/Write Address: VP_Base+20h/3?5h, Index e0, e1, e2, e3

Power-on Default: Undefined

This register specifies video source data line width and offset address for video window I.

31	30	29	28	27	26	25	24	23	22	21	20	19	18	17	16
RESERVED						VIDEO WINDOW I SOURCE DATA LINE									
15	14	13	12	11	10	9	8	7	6	5	4	3	2	1	0
RESERVED						VIDEO WINDOW I SOURCE ADDRESS									

Bit 31:26 Reserved**Bit 25:16** Video Window I Source Data Line Width, in 64-bit segment**Bit 15:10** Reserved**Bit 9:0** Video Window I Source Address Offset, in 64-bit segment

VPR24: Video Window I Stretch Factor:

Read/Write Address: VP_Base+24h/3?5h, Index e4, e5, e6, e7

Power-on Default: 00000000h

This register specifies video horizontal and Vertical stretch factor for video window I. For optimal display quality, we recommend destination to source ratio to be maximum of 4:1. The two high bytes of this register can be used to enable the “Bob” function.

31	30	29	28	27	26	25	24	23	22	21	20	19	18	17	16
VIDEO WINDOW II INITIAL ODD FIELD								VIDEO WINDOW II INITIAL EVEN FIELD							
15	14	13	12	11	10	9	8	7	6	5	4	3	2	1	0
VIDEO WINDOW I HORIZONTAL STRETCH								VIDEO WINDOW I VERTICAL STRETCH							

Bit 31:24 Video Window II Initial Odd Field Vertical Scale Factor**Bit 23:16** Video Window II Initial Even Field Vertical Scale Factor

Bit 15:8 Video Window 1 Horizontal Stretch Factor (W1HSF)
 note: when stretch factor is set to 0, it becomes a 1-to-1 stretch

$$W1HSF = \frac{\text{Source}}{\text{Destination}} * 256$$

Bit 7:0 Video Window 1 Vertical Stretch Factor (W1VSF)
 note: when stretch factor is set to 0, it becomes a 1-to-1 stretch

$$W1VSF = \left(1 - \frac{\text{Source}}{\text{Destination}} \right) * 256$$

VPR28: Video Window II Left and Top Boundaries

Read/Write Address: VP_Base+28h
 Power-on Default: Undefined

This register specifies left and top boundary for video window II.

31	30	29	28	27	26	25	24	23	22	21	20	19	18	17	16
RESERVED					VIDEO WINDOW II TOP BOUNDARY										
15	14	13	12	11	10	9	8	7	6	5	4	3	2	1	0
RESERVED					VIDEO WINDOW II LEFT BOUNDARY										

- Bit 31:27** Reserved
- Bit 26:16** Video Window II, Top Boundary
- Bit 15:11** Reserved
- Bit 10:0** Video Window II, Left Boundary

VPR2C: Video Window II Right and Bottom Boundaries

Read/Write Address: VP_Base+2Ch
 Power-on Default: Undefined

This register specifies right and bottom boundary for video window II.

31	30	29	28	27	26	25	24	23	22	21	20	19	18	17	16
RESERVED					VIDEO WINDOW II BOTTOM BOUNDARY										
15	14	13	12	11	10	9	8	7	6	5	4	3	2	1	0
RESERVED					VIDEO WINDOW II RIGHT BOUNDARY										

- Bit 31:27** Reserved
- Bit 26:16** Video Window II, Bottom Boundary

Bit 15:11 Reserved**Bit 10:0** Video Window II, Right Boundary

VPR30: Video Window II Source Start Address

Read/Write Address: VP_Base+30h

Power-on Default: Undefined

This register specifies video start address for video window II.

31	30	29	28	27	26	25	24	23	22	21	20	19	18	17	16
VWIIS	RESERVED									VWIIDS					
15	14	13	12	11	10	9	8	7	6	5	4	3	2	1	0
VWIIDS															

Bit 31 Video Window II Status Bits (VWIIS)**Bit 30:22** Reserved**Bit 21:0** Video Window II Data Source Starting Address (VWIIDS)

VPR34: Video Window II Source Width and Offset

Read/Write Address: VP_Base+34h

Power-on Default: Undefined

This register specifies video source data line width and offset address for video window II.

31	30	29	28	27	26	25	24	23	22	21	20	19	18	17	16
RESERVED						VIDEO WINDOW II SOURCE DATA LINE									
15	14	13	12	11	10	9	8	7	6	5	4	3	2	1	0
RESERVED						VIDEO WINDOW II SOURCE ADDRESS									

Bit 31:26 Reserved**Bit 25:16** Video Window II Source Data Line Width, in 64-bit segment**Bit 15:10** Reserved**Bit 9:0** Video Window II Source Address Offset, in 64-bit segment

VPR38: Video Window II Stretch Factor

Read/Write Address: VP_Base+38h/3?5h, Index f8, f9, fa, fb

Power-on Default: 0000000h

This register specifies video horizontal and Vertical stretch factor for video window II. For optimal display quality, we recommend destination to source ratio to be maximum of 4:1.

31	30	29	28	27	26	25	24	23	22	21	20	19	18	17	16
VIDEO WINDOW II INITIAL ODD FIELD								VIDEO WINDOW II INITIAL EVEN FIELD							
15	14	13	12	11	10	9	8	7	6	5	4	3	2	1	0
VIDEO WINDOW II HORIZONTAL STRETCH								VIDEO WINDOW II VERTICAL STRETCH							

Bit 31:24 Video Window II Initial Odd Field Vertical Scale Factor

Bit 23:16 Video Window II Initial Even Field Vertical Scale Factor

Bit 15:8 Video Window II Horizontal Stretch Factor (W2HSF)

note: when stretch factor is set to 0, it becomes a 1-to-1 stretch

$$W2HSF = \frac{\text{Source}}{\text{Destination}} * 256$$

Bit 7:0 Video Window II Vertical Stretch Factor (W2VSF)

note: when stretch factor is set to 0, it becomes a 1-to-1 stretch

$$W2VSF = \left(1 - \frac{\text{Source}}{\text{Destination}} \right) * 256$$

VPR3C: Graphics and Video Control II

Read/Write: Address: VP_Base+3Ch/3?5h, Index fc, fd, fe

Power-on Default: 000000h

31	30	29	28	27	26	25	24	23	22	21	20	19	18	17	16
RESERVED									ESP 2-1	ESP 4-3	ESPV	R	SPVW	ESP 2-Bit	ESP
15	14	13	12	11	10	9	8	7	6	5	4	3	2	1	0
R	EGHS 2-1	EGHS 4-3	EGVS	EGVSF	EGHR	EGVI	EGFR	EVWII 420i	EVWII 2-1	EVWII 4-3	EVWII VS	EVWI 420i	EVWI 2-1	EVWI 4-3	EVWI VS

Bit 31:23 Reserved

Bit 22 Enable Sub-Picture 2-to-1 Horizontal Shrink (ESP 2-1)

Bit 21 Enable Sub-Picture 4-to-3 Horizontal Shrink (ESP 4-3)

Bit 20 Enable Sub-Picture Vertical Shrink (ESPV)

Bit 19 Reserved (R)

Bit 18 Sub-Picture on Video Window II (SPVW)

Bit 17	Enable 2-bit/pixel Sub-Picture (Otherwise 8-bit/pixel) (ESP 2-Bit)
Bit 16	Enable Sub-Picture (ESP)
Bit 15	Reserved (R)
Bit 14	Enable Graphic 2-to-1 Horizontal Shrink (EGHS 2-1)
Bit 13	Enable Graphic 4-to-3 Horizontal Shrink (EGHS 4-3)
Bit 12	Enable Graphic Vertical Shrink (EGVS)
Bit 11	Enable Graphic Vertical Scale Factor to 80H (EGVSF)
Bit 10	Enable Graphic Horizontal Replication (EGHR)
Bit 9	Enable Graphic Vertical Interpolation (EGVI)
Bit 8	Enable Graphic 3-Line Flicker Reduction (EGFR)
Bit 7	Enable Video Window II 420i UV Swap (EVWII 420i)
Bit 6	Enable Video Window II 2-to-1 Horizontal Shrink (EVWII 2-1)
Bit 5	Enable Video Window II 4-to-3 Horizontal Shrink (EVWII 4-3)
Bit 4	Enable Video Window II Vertical Shrink (EVWIIVS)
Bit 3	Enable Video Window I 420i UV Swap (EVWI 420i)
Bit 2	Enable Video Window I 2-to-1 Horizontal Shrink (EVWI 2-1)
Bit 1	Enable Video Window I 4-to-3 Horizontal Shrink (EVWI 4-3)
Bit 0	Enable Video Window I Vertical Shrink (EVWIVS)

VPR40: Graphic Scale Factor

Read/Write Address: VP_Base+40h/3?5h, Index e8, e9, ea, eb
Power-on Default: 00000000h

31	30	29	28	27	26	25	24	23	22	21	20	19	18	17	16
GRAPHIC INITIAL ODD FIELD VERTICAL								GRAPHIC INITIAL EVEN FIELD VERTICAL							
15	14	13	12	11	10	9	8	7	6	5	4	3	2	1	0
GRAPHIC HORIZONTAL SCALE FACTOR								GRAPHIC VERTICAL SCALE FACTOR							

Bit 31:24 Graphic Initial Odd Field Vertical Scale Factor

Bit 23:16 Graphic Initial Even Field Vertical Scale Factor**Bit 15:8** Graphic Horizontal Scale Factor (GHSF)
$$\text{GHSF} = \frac{\text{Source}}{\text{Destination}} * 256$$
Bit 7:0 Graphic Vertical Scale Factor (GVSF)
$$\text{GVSF} = \left(1 - \frac{\text{Source}}{\text{Destination}_n} \right) * 256$$
VPR44: Graphic Data Source Starting Address for Odd FieldRead/Write Address: VP_Base+44h/3?5h, Index ec, ed, ee
Power-on Default: Undefined

31	30	29	28	27	26	25	24	23	22	21	20	19	18	17	16
RESERVED											GRAPHIC DATA SOURCE				
15	14	13	12	11	10	9	8	7	6	5	4	3	2	1	0
GRAPHIC DATA SOURCE															

Bit 31:20 Reserved**Bit 19:0** Graphic Data Source Starting Address for Odd Field**VPR48: Video Window I Chroma Data Source Starting Address**Read/Write Address: VP_Base+48h
Power-on Default: Undefined

31	30	29	28	27	26	25	24	23	22	21	20	19	18	17	16
RESERVED											VIDEO WINDOW I				
15	14	13	12	11	10	9	8	7	6	5	4	3	2	1	0
VIDEO WINDOW I															

Bit 31:20 Reserved**Bit 19:0** Video Window I Chroma Data Source Starting Address**VPR4C: Video Window II Chroma Data Source Starting Address**Read/Write Address: VP_Base+4Ch
Power-on Default: Undefined

31	30	29	28	27	26	25	24	23	22	21	20	19	18	17	16
RESERVED												VIDEO WINDOW II			
15	14	13	12	11	10	9	8	7	6	5	4	3	2	1	0
VIDEO WINDOW II															

Bit 31:20 Reserved

Bit 19:0 Video Window II Chroma Data Source Starting Address

VPR50: Sub-Picture Data Source Starting Address

Read/Write Address: VP_Base=50h

Power-on Default: Undefined

31	30	29	28	27	26	25	24	23	22	21	20	19	18	17	16
RESERVED												SUB-PICTURE DATA SOURCE			
15	14	13	12	11	10	9	8	7	6	5	4	3	2	1	0
SUB-PICTURE DATA SOURCE															

Bit 31:20 Reserved

Bit 19:0 Sub-picture Data Source Starting Address

VPR54: FIFO Priority Control

Read/Write Address: VP_Base+54h/3?5h, Index f0, f1, f2, f3

Power-on Default: 07216543h

This register specifies FIFO priority controls for graphics, Flat Panel Read Frame Buffer FIFO1, Video Window I, Video Window II, Flat Panel Write Frame Buffer, Capture Window and Flat Panel Read Frame Buffer FIFO2. Graphics FIFO has the highest priority and Flat Panel Read FIFO2 has the lowest priority as default.

31	30	29	28	27	26	25	24	23	22	21	20	19	18	17	16
ERRP	EDE1	EDE2	EHIF	EHIF MIF	FPR FIFO2			R	CWFIFO			R	FPW FIFO		
15	14	13	12	11	10	9	8	7	6	5	4	3	2	1	0
R	VWII FIFO			R	VWI FIFO			R	FPR FIFO1			R	GFIFO		

Bit 31 Enable Round Robin Priority Arbitration (ERRP)

Bit 30 Enable DE1 Burst of 4 Data (EDE1)

Bit 29 Enable DE2 Burst of 4 Data (EDE2)

- Bit 28** Enable HIF Master burst of 4 Data (EHIF)
- Bit 27** Enable HIF MIF Burst of 4 Data (EHIF MIF)
- Bit 26:24** Flat Panel Read FIFO2 priority select (FPR FIFO2)
 000 = request is off
 001 = highest priority (1st)
 010 = next priority (2nd)
 011 = next priority (3rd)
 100 = next priority (4th)
 101 = next priority (5th)
 110 = next priority (6th)
 111 = lowest priority (last) (default)
- Bit 23** Reserved (R)
- Bit 22:20** Capture Window FIFO priority select (CWFIFO)
 000 = request is off
 001 = highest priority (1st)
 010 = next priority (2nd) (default)
 011 = next priority (3rd)
 100 = next priority (4th)
 101 = next priority (5th)
 110 = next priority (6th)
 111 = lowest priority (last)
- Bit 19** Reserved (R)
- Bit 18:16** Flat Panel Write FIFO priority select (FPW FIFO)
 000 = request is off
 001 = highest priority (1st) (default)
 010 = next priority (2nd)
 011 = next priority (3rd)
 100 = next priority (4th)
 101 = next priority (5th)
 110 = next priority (6th)
 111 = lowest priority (last)
- Bit 15** Reserved (R)
- Bit14:12** Video Window II FIFO priority select (VWII FIFO)
 000 = request is off
 001 = highest priority (1st)
 010 = next priority (2nd)
 011 = next priority (3rd)
 100 = next priority (4th)
 101 = next priority (5th)
 110 = next priority (6th) (default)
 111 = lowest priority (last)

- Bit 11** Reserved (R)
- Bit 10:8** Video Window I FIFO priority select (VWI FIFO)
 000 = request is off
 001 = highest priority (1st)
 010 = next priority (2nd)
 011 = next priority (3rd)
 100 = next priority (4th)
 101 = next priority (5th) (default)
 110 = next priority (6th)
 111 = lowest priority (last)
- Bit 7** Reserved (R)
- Bit 6:4** Flat Panel Read FIFO1 priority select (FPR FIFO1)
 000 = request is off
 001 = highest priority (1st)
 010 = next priority (2nd)
 011 = next priority (3rd)
 100 = next priority (4th) (default)
 101 = next priority (5th)
 110 = next priority (6th)
 111 = lowest priority (last)
- Bit 3** Reserved
- Bit 2:0** Graphics FIFO priority select (GFIFO)
 000 = request is off
 001 = highest priority (1st)
 010 = next priority (2nd)
 011 = next priority (3rd) (default)
 100 = next priority (4th)
 101 = next priority (5th)
 110 = next priority (6th)
 111 = lowest priority (last)

VPR58: FIFO Empty Request level Control

Read/Write Address: VP_Base+58h/3?5h, Index f4, f5
 Power-on Default: 00000444h

This register specifies FIFO empty request level for graphics FIFO, Video Window I, and Video Window II. At the specified empty FIFO level, FIFO request will be generated. Default FIFO empty levels are all 6 or more empty. For LCD Read FIFO1/FIFO2 and LCD Write FIFO request level controls, they are located in FPR4A register.

31	30	29	28	27	26	25	24	23	22	21	20	19	18	17	16	
RESERVED																
15	14	13	12	11	10	9	8	7	6	5	4	3	2	1	0	
RESERVED				VWII FIFO				R	VWI FIFO				R	GFIFO		

- Bit 31:11** Reserved
- Bit 10:8** Video Window II FIFO Empty request level Select (VWII FIFO)
 000 = 2 or more empty
 001 = 3 or more empty
 010 = 4 or more empty
 011 = 5 or more empty
 100 = 6 or more empty (default)
 101 = 8 or more empty
 110 = 10 or more empty
 111 = 12 or more empty
- Bit 7** Reserved (R)
- Bit 6:4** Video Window I FIFO Empty request level Select (VWI FIFO)
 000 = 2 or more empty
 001 = 3 or more empty
 010 = 4 or more empty
 011 = 5 or more empty
 100 = 6 or more empty (default)
 101 = 8 or more empty
 110 = 10 or more empty
 111 = 12 or more empty
- Bit 3** Reserved (R)
- Bit 2:0** Graphics FIFO Empty request level Select (GFIFO)
 000 = 2 or more empty
 001 = 3 or more empty
 010 = 4 or more empty
 011 = 5 or more empty
 100 = 6 or more empty (default)
 101 = 8 or more empty
 110 = 10 or more empty
 111 = 12 or more empty

VPR5C: YUV to RGB Conversion Constant

Read/Write Address: VP_Base+5Ch

Power-on Default: EDEDEDh

This register specifies the YUV to RGB conversion constant.

31	30	29	28	27	26	25	24	23	22	21	20	19	18	17	16
LUMA Y ADJUSTMENT								RED CONVERSION CONSTANT							
15	14	13	12	11	10	9	8	7	6	5	4	3	2	1	0
GREEN CONVERSION CONSTANT								BLUE CONVERSION CONSTANT							

Bit 31:24 Luma Y Adjustment

Bit 23:16 Red Conversion Constant**Bit 15:8** Green Conversion Constant**Bit 7:0** Blue Conversion Constant

VPR60: Current Scan Line Position

Read Only Address: VP_Base+60h

Power-on Default: Undefined

This register specifies the current scan line position.

31	30	29	28	27	26	25	24	23	22	21	20	19	18	17	16
RESERVED															
15	14	13	12	11	10	9	8	7	6	5	4	3	2	1	0
RESERVED						CURRENT SCAN LINE									

Bit 31:11 Reserved**Bit 10:0** Current Scan Line. This register returns the number for current scan line.

VPR64: Signature Analyzer Control and Status

Read/Write Address: VP_Base+64h

Power-on Default: Undefined

This register specifies controls and status for signature analyzer as well as the analyzer signature.

31	30	29	28	27	26	25	24	23	22	21	20	19	18	17	16
ANALYZER SIGNATURE															
15	14	13	12	11	10	9	8	7	6	5	4	3	2	1	0
RESERVED												SAE	SAR	SASS	

Bit 31:16 Analyzer Signature. These bits are Ready Only.**Bit 15:4** Reserved**Bit 3** Signature Analyzer Enable/Stop. Software needs to set this bit = 1 as a "ENABLE" control bit in order to enable signature analyzer. Once the analysis is completed, the hardware will reset this bit = 0 as a "STOP" status bit. (SAE)

0 = Stop (analysis is completed)

1 = Enable (analysis is in progress)

Bit 2 Signature Analyzer Reset/Normal. Software needs to set this bit = 1 as a (SAR)

"RESET" control bit to reset signature shift register to "0" before turning on signature analyzer. In the next vertical sync pulse after bit 3 and bit 2 have been set to "11", bit 2 will be automatically reset to "0" as a "NORMAL" status bit.

- 0 = Normal (disable reset to signature analyzer)
- 1 = Reset (enable reset to signature analyzer)

Bit 1:0 Signature Analyzer Source Select. These bits selects the input source for the signature analyzer. (SASS)
 00 = Source is Red output from Multimedia RAMDAC
 01 = Source is Green output from Multimedia RAMDAC
 1x = Source is Blue output from Multimedia RAMDAC

VPR70: Sub Picture Color Look Up Register 0

Read/Write Address: VP_Base+70h
 Power-on Default: Undefined

31	30	29	28	27	26	25	24	23	22	21	20	19	18	17	16
RESERVED								SUB PICTURE COLOR LOOK UP 0							
15	14	13	12	11	10	9	8	7	6	5	4	3	2	1	0
SUB PICTURE COLOR LOOK UP 0															

Bit 31:24 Reserved

Bit 23:0 Sub Picture Color Look Up Register 0

VPR74: Sub Picture Color Look Up Register 1

Read/Write Address: VP_Base+74h
 Power-on Default: Undefined

31	30	29	28	27	26	25	24	23	22	21	20	19	18	17	16
RESERVED								SUB PICTURE COLOR LOOK UP 1							
15	14	13	12	11	10	9	8	7	6	5	4	3	2	1	0
SUB PICTURE COLOR LOOK UP 1															

Bit 31:24 Reserved

Bit 23:0 Sub Picture Color Look Up Register 1

VPR78: Sub Picture Color Look Up Register 2

Read/Write Address: VP_Base+78h
 Power-on Default: Undefined

31	30	29	28	27	26	25	24	23	22	21	20	19	18	17	16
RESERVED								SUB PICTURE COLOR LOOK UP 2							
15	14	13	12	11	10	9	8	7	6	5	4	3	2	1	0
SUB PICTURE COLOR LOOK UP 2															

Bit 31:24 Reserved**Bit 23:0** Sub Picture Color Look Up Register 2**VPR7C: Sub Picture Color Look Up Register 3**

Read/Write Address: VP_Base+7Ch

Power-on Default: Undefined

31	30	29	28	27	26	25	24	23	22	21	20	19	18	17	16
RESERVED								SUB PICTURE COLOR LOOK UP 3							
15	14	13	12	11	10	9	8	7	6	5	4	3	2	1	0
SUB PICTURE COLOR LOOK UP 3															

Bit 31:24 Reserved**Bit 23:0** Sub Picture Color Look Up Register 3**VPR80: Sub Picture Color Look Up Register 4**

Read/Write Address: VP_Base+80h

Power-on Default: Undefined

31	30	29	28	27	26	25	24	23	22	21	20	19	18	17	16
RESERVED								SUB PICTURE COLOR LOOK UP 4							
15	14	13	12	11	10	9	8	7	6	5	4	3	2	1	0
SUB PICTURE COLOR LOOK UP 4															

Bit 31:24 Reserved**Bit 23:0** Sub Picture Color Look Up Register 4**VPR84: Sub Picture Color Look Up Register 5**

Read/Write Address: VP_Base+84h

Power-on Default: Undefined

31	30	29	28	27	26	25	24	23	22	21	20	19	18	17	16
RESERVED								SUB PICTURE COLOR LOOK UP 5							
15	14	13	12	11	10	9	8	7	6	5	4	3	2	1	0
SUB PICTURE COLOR LOOK UP 5															

Bit 31:24 Reserved

Bit 23:0 Sub Picture Color Look Up Register 5

VPR88: Sub Picture Color Look Up Register 6

Read/Write Address: VP_Base+88h
Power-on Default: Undefined

31	30	29	28	27	26	25	24	23	22	21	20	19	18	17	16
RESERVED								SUB PICTURE COLOR LOOK UP 6							
15	14	13	12	11	10	9	8	7	6	5	4	3	2	1	0
SUB PICTURE COLOR LOOK UP 6															

Bit 31:24 Reserved

Bit 23:0 Sub Picture Color Look Up Register 6

VPR8C: Sub Picture Color Look Up Register 7

Read/Write Address: VP_Base+8Ch
Power-on Default: Undefined

31	30	29	28	27	26	25	24	23	22	21	20	19	18	17	16
RESERVED								SUB PICTURE COLOR LOOK UP 7							
15	14	13	12	11	10	9	8	7	6	5	4	3	2	1	0
SUB PICTURE COLOR LOOK UP 7															

Bit 31:24 Reserved

Bit 23:0 Sub Picture Color Look Up Register 7

VPR90: Sub Picture Color Look Up Register 8

Read/Write Address: VP_Base+90h
Power-on Default: Undefined

31	30	29	28	27	26	25	24	23	22	21	20	19	18	17	16
RESERVED								SUB PICTURE COLOR LOOK UP 8							
15	14	13	12	11	10	9	8	7	6	5	4	3	2	1	0
SUB PICTURE COLOR LOOK UP 8															

Bit 31:24 Reserved

Bit 23:0 Sub Picture Color Look Up Register 8

VPR94: Sub Picture Color Look Up Register 9

Read/Write Address: VP_Base+94h

Power-on Default: Undefined

31	30	29	28	27	26	25	24	23	22	21	20	19	18	17	16
RESERVED								SUB PICTURE COLOR LOOK UP 9							
15	14	13	12	11	10	9	8	7	6	5	4	3	2	1	0
SUB PICTURE COLOR LOOK UP 9															

Bit 31:24 Reserved

Bit 23:0 Sub Picture Color Look Up Register 9

VPR98: Sub Picture Color Look Up Register A

Read/Write Address: VP_Base+98h

Power-on Default: Undefined

31	30	29	28	27	26	25	24	23	22	21	20	19	18	17	16
RESERVED								SUB PICTURE COLOR LOOK UP A							
15	14	13	12	11	10	9	8	7	6	5	4	3	2	1	0
SUB PICTURE COLOR LOOK UP A															

Bit 31:24 Reserved

Bit 23:0 Sub Picture Color Look Up Register A

VPR9C: Sub Picture Color Look Up Register B

Read/Write Address: VP_Base+9Ch

Power-on Default: Undefined

31	30	29	28	27	26	25	24	23	22	21	20	19	18	17	16
RESERVED								SUB PICTURE COLOR LOOK UP B							
15	14	13	12	11	10	9	8	7	6	5	4	3	2	1	0
SUB PICTURE COLOR LOOK UP B															

Bit 31:24 Reserved

Bit 23:0 Sub Picture Color Look Up Register B

VPRA0: Sub Picture Color Look Up Register C

Read/Write Address: VP_Base+A0h

Power-on Default: Undefined

31	30	29	28	27	26	25	24	23	22	21	20	19	18	17	16
RESERVED								SUB PICTURE COLOR LOOK UP C							
15	14	13	12	11	10	9	8	7	6	5	4	3	2	1	0
SUB PICTURE COLOR LOOK UP C															

Bit 31:24 Reserved

Bit 23:0 Sub Picture Color Look Up Register C

VPRA4: Sub Picture Color Look Up Register D

Read/Write Address: VP_Base+A4h

Power-on Default: Undefined

31	30	29	28	27	26	25	24	23	22	21	20	19	18	17	16
RESERVED								SUB PICTURE COLOR LOOK UP D							
15	14	13	12	11	10	9	8	7	6	5	4	3	2	1	0
SUB PICTURE COLOR LOOK UP D															

Bit 31:24 Reserved

Bit 23:0 Sub Picture Color Look Up Register D

VPRA8: Sub Picture Color Look Up Register E

Read/Write Address: VP_Base+A8h

Power-on Default: Undefined

31	30	29	28	27	26	25	24	23	22	21	20	19	18	17	16
RESERVED								SUB PICTURE COLOR LOOK UP E							
15	14	13	12	11	10	9	8	7	6	5	4	3	2	1	0
SUB PICTURE COLOR LOOK UP E															

Bit 31:24 Reserved**Bit 23:0** Sub Picture Color Look Up Register E**VPRAC: Sub Picture Color Look Up Register F**

Read/Write Address: VP_Base+ACh

Power-on Default: Undefined

31	30	29	28	27	26	25	24	23	22	21	20	19	18	17	16
RESERVED								SUB PICTURE COLOR LOOK UP F							
15	14	13	12	11	10	9	8	7	6	5	4	3	2	1	0
SUB PICTURE COLOR LOOK UP F															

Bit 31:24 Reserved**Bit 23:0** Sub Picture Color Look Up Register F**VPRB0: Sub Picture Top/Left Boundary**

Read/Write Address: VP_Base+B0h

Power-on Default: Undefined

31	30	29	28	27	26	25	24	23	22	21	20	19	18	17	16
RESERVED					SUB PICTURE TOP BOUNDARY										
15	14	13	12	11	10	9	8	7	6	5	4	3	2	1	0
RESERVED					SUB PICTURE LEFT BOUNDARY										

Bit 31:27 Reserved**Bit 26:16** Sub Picture Top Boundary**Bit 15:11** Reserved**Bit 10:0** Sub Picture Left Boundary**VPRB4: Sub Picture Bottom/Right Boundary**

Read/Write Address: VP_Base+B4h

Power-on Default: Undefined

31	30	29	28	27	26	25	24	23	22	21	20	19	18	17	16
RESERVED						SUB PICTURE BOTTOM BOUNDARY									
15	14	13	12	11	10	9	8	7	6	5	4	3	2	1	0
RESERVED						SUB PICTURE RIGHT BOUNDARY									

Bit 31:27 Reserved**Bit 26:16** Sub Picture Bottom Boundary**Bit 15:11** Reserved**Bit 10:0** Sub Picture Right Boundary**VPRB8: Sub Picture Source Data Address Offset and Line Width**

Read/Write Address: VP_Base+B8h

Power-on Default: Undefined

31	30	29	28	27	26	25	24	23	22	21	20	19	18	17	16
RESERVED						SUB PICTURE SOURCE DATA LINE									
15	14	13	12	11	10	9	8	7	6	5	4	3	2	1	0
RESERVED						SUB PICTURE SOURCE DATA ADDRESS OFFSET									

Bit 31:26 Reserved**Bit 25:16** Sub Picture Source Data Line Width**Bit 15:10** Reserved**Bit 9:0** Sub Picture Source Data Address Offset**VPRC0: Video Window I U/V Scale Factor**

Read/Write Address: VP_Base+C0h

Power-on Default: 000000h

31	30	29	28	27	26	25	24	23	22	21	20	19	18	17	16
RESERVED							EVWI	VIDEO WINDOW I UV INITIAL ODD							
15	14	13	12	11	10	9	8	7	6	5	4	3	2	1	0
VIDEO WINDOW I UV INITIAL EVEN								VIDEO WINDOW I UV VERTICAL							

Bit 31:25 Reserved

- Bit 24** Enable Video Window I UV Vertical Shrink(EVWI)
- Bit 23:16** Video Window I UV Initial Odd Field Vertical Scale Factor
- Bit 15:8** Video Window I UV Initial Even Field Vertical Scale Factor
- Bit 7:0** Video Window I UV Vertical Scale Factor

VPRC4: Video Window II Scale Factor

Read/Write Address: VP_Base+C4h
Power-On Default: 000000h

31	30	29	28	27	26	25	24	23	22	21	20	19	18	17	16
RESERVED							EVWII	VIDEO WINDOW II UV INITIAL ODD							
15	14	13	12	11	10	9	8	7	6	5	4	3	2	1	0
VIDEO WINDOW II UV INITIAL EVEN							VIDEO WINDOW II UV VERTICAL								

- Bit 31:25** Reserved
- Bit 24** Enable Video Window II UV Vertical Shrink (EVWII)
- Bit 23:16** Video Window II UV Initial Odd Field Vertical Scale Factor
- Bit 15:8** Video Window II UV Initial Even Field Vertical Scale Factor
- Bit 7:0** Video Window II UV Vertical Scale Factor

Capture Processor Control Registers

The Capture Processor Control Registers specify the control registers for Capture Processor The Capture Processor Control Registers can only be accessed through memory-mapped.

CPR00: Capture Port Control

Read/Write Address: CP_Base+00h
Power-on Default: 00h

This register specifies the capture port which can be used for video capture and video playback.

31	30	29	28	27	26	25	24	23	22	21	20	19	18	17	16
RESERVED						EMO	FDMS	VREF	HREF	EHF		EVR		EHR	
15	14	13	12	11	10	9	8	7	6	5	4	3	2	1	0
VDI		FSE			IDCE	DBE	CC	FIS	IS	CBS	CFO	VIS	BUF2	BUF1	VCE

- Bit 31:26** Reserved

- Bit 25** External Memory Only Select (Read Only). This register bit definition is opposite from the MD[23] definition in the Table 3: Power on Configuration. (EMO)
0 = Normal. Allow both internal and external memory access depends on MD[2]/MCR62[2] setting.
1 = External Memory Access Only
- Bit 24** Field Detect Method Select (FDMS)
0 = Falling edge of VSYNC
1 = Rising edge of VSYNC
- Bit 23** VREF Polarity (VREF)
0 = "High" active
1 = "Low" active
- Bit 22** HREF Polarity (HREF)
0 = "High" active
1 = "Low" active
- Bit 21:20** Enable Horizontal Filtering (EHF)
00 = no filtering
01 = 2-tap filtering
10 = 3-tap filtering
11 = 4-tap filtering
- Bit 19:18** Enable Vertical Reduction (EVR)
00 = no reduction
01 = 2 to 1 reduction
10 = 4 to 1 reduction
11 = reserved
- Bit 17:16** Enable Horizontal Reduction (EHR)
00 = no reduction
01 = 2 to 1 reduction
10 = 4 to 1 reduction
11 = reserved
- Bit 15:14** Video Capture Input Data Format (VDI)
00 = YUV 4:2:2
01 = YUV 4:2:2 (with byte swapping)
10 = RGB 5:5:5
11 = RGB 5:6:5
- Bit 13:11** Frame Skip Enable (FSE)
000 = no skip
001 = skip every other frame
010 = skip even frame
011 = skip odd frame
100 = capture 2 and skip 1 frame
101 = capture 3 and skip 1 frame
110 = capture 1 and skip 2 frame

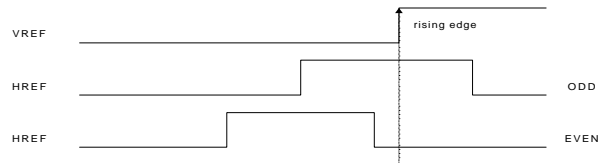

111 = capture 1 and skip 3 frame

- Bit 10** Interlace Data Capture Enable (IDCE)
0 = Disable (non-interlace)
1 = Enable (interlace data. even field will be captured into buffer1 and odd field will be captured into buffer2) When this bit is set to 1, double buffer mode needs to be also enabled (bit 9 =1).
- Bit 9** Double Buffer Enable (DBE)
0 = Disable. Use buffer1 addressed by VPR48.
1 = Enable. Use buffer1 and buffer2 addressed by VPR48 and VPR4C.
- Bit 8** Capture Control (CC)
0 = Continuous Capture
1 = Conditional Capture. Capture is controlled by bit 1 or bit 2 of this register.
- Bit 7** Field Input Status (Read Only) (FIS)
0 = even field
1 = odd field
- Bit 6** Interlace Status (Read Only) (IS)
0 = non-interlace
1 = interlace
- Bit 5** Current Buffer Status (Read Only) (CBS)
0 = Buffer 1 is the current buffer used
1 = Buffer 2 is the current buffer used
- Bit 4** Current Frame Capture Status (Read Only) (CFO)
0 = Skip the current frame
1 = Capture the current frame
- Bit 3** VSYNC Input Status (Read Only) (VIS)
0 = VSYNC pulse is inactive
1 = VSYNC pulse is active
- Bit 2** Buffer 2 Status/Control Bit. This bit is used for software to read back the status of the current frame. Software needs to preset this bit to 1 when programming the Buffer 2 starting address in VPR4C. This bit can be set by drawing engine, and it can also be reset by video capture unit. If continuous capture is selected (bit 8 =0), this bit will be ignored. (BUF2)
0 = Idle or Capture has completed
1 = Capture in progress
- Bit 1** Buffer 1 Status/Control Bit. This bit is used for software to read back the status of the current frame. Software needs to preset this bit to 1 when programming the Buffer 1 starting address in VPR48. This bit can be set by drawing engine, and it can also be reset by video capture unit. If continuous capture is selected (bit 8 =0), this bit will be ignored. (BUF1)
0 = Idle or Capture has completed
1 = Capture in progress

Bit 0 Video Capture Enable. When Video Capture is enabled, all video port I/O pins except for "BLANK" pin will become input pins only. This bit can also be accessed through I/O register space 3?5, index FF, bit [0]. (VCE)
0 = Disable
1 = Enable

CPR04: Video Source Clipping Control

Read/Write Address: CP_Base+04h
Power-on Default: Undefined

This register specifies top and left clipping of video source.

31	30	29	28	27	26	25	24	23	22	21	20	19	18	17	16
RESERVED						VIDEO SOURCE TOP CLIPPING									
15	14	13	12	11	10	9	8	7	6	5	4	3	2	1	0
RESERVED						VIDEO SOURCE LEFT CLIPPING									

Bit 31:26 Reserved

Bit 25:16 Video Source Top Clipping, # of line to drop

Bit 15:10 Reserved

Bit 9:0 Video Source Left Clipping, # of pixel to drop

CPR08: Video Source Capture Size Control

Read/Write Address: CP_Base+08h
Power-on Default: Undefined

This register specifies video source capture size.

31	30	29	28	27	26	25	24	23	22	21	20	19	18	17	16
RESERVED					VIDEO SOURCE HEIGHT										
15	14	13	12	11	10	9	8	7	6	5	4	3	2	1	0
RESERVED					VIDEO SOURCE WIDTH										

Bit 31:27 Reserved

Bit 26:16 Video Source Height

Bit 15:11 Reserved

Bit 10:0 Video Source Width

CPR0C: Capture Port Buffer I Source Start Address

Read/Write Address: CP_Base+0Ch

Power-on Default: Undefined

This register specifies video source start address for Buffer I of Capture Port.

31	30	29	28	27	26	25	24	23	22	21	20	19	18	17	16
RESERVED											CAPTURE PORT I				
15	14	13	12	11	10	9	8	7	6	5	4	3	2	1	0
CAPTURE PORT I															

Bit 31:21 Reserved**Bit 20:0** Capture Port Buffer I source start address, in 64-bit segment**CPR10: Capture Port Buffer II Source Start Address**

Read/Write Address: CP_Base+10h

Power-on Default: Undefined

This register specifies video source start address for Buffer II of Capture Port.

31	30	29	28	27	26	25	24	23	22	21	20	19	18	17	16
RESERVED											CAPTURE PORT II				
15	14	13	12	11	10	9	8	7	6	5	4	3	2	1	0
CAPTURE PORT II															

Bit 31:21 Reserved**Bit 20:0** Capture Port Buffer II source start address, in 64-bit segment.**CPR14: Capture Port Source Offset Address**

Read/Write Address: CP_Base+14h

Power-on Default: Undefined

This register specifies video source offset address for Capture Port.

31	30	29	28	27	26	25	24	23	22	21	20	19	18	17	16
RESERVED															
15	14	13	12	11	10	9	8	7	6	5	4	3	2	1	0
RESERVED						CAPTURE PORT SOURCE									

Bit 31:11 Reserved**Bit 10:0** Capture Port Source Address Offset, in 64-bit segment**CPR18: Capture FIFO Empty Request level Control**

Read/Write Address: CP_Base+18h

Power-on Default: 00000006h

This register specifies Capture FIFO empty request level. At the specified empty FIFO level, FIFO request will be generated. Default FIFO empty levels are all 6 or more empty.

31	30	29	28	27	26	25	24	23	22	21	20	19	18	17	16
RESERVED															
15	14	13	12	11	10	9	8	7	6	5	4	3	2	1	0
RESERVED													CAPTURE WINDOW		

Bit 31:3 Reserved**Bit 2:0** Capture Window FIFO Empty request level Select

000 = 2 or more empty

001 = 3 or more empty

010 = 4 or more empty

011 = 5 or more empty

100 = 6 or more empty

101 = 8 or more empty

110 = 10 or more empty (default)

111 = 12 or more empty

Chapter 23: Motion Comp Video Registers

Table 29: Motion Comp Video Registers Quick Reference

Summary of Registers	Page
<i>Motion Comp Bus Master CMD Control Registers</i>	
MCR00: Motion Comp Enable	23 - 2
MCR04: Slot 0 Y Data Source	23 - 2
MCR08: Slot1 Y Data Source	23 - 2
MCR0C: Slot2 Y Data Source	23 - 2
MCR10: Slot3 Y Data Source	23 - 3
MCR14: Slot0 UV Interleave Data Source	23 - 3
MCR18: Slot1 UV Interleave Data Source	23 - 3
MCR1C: Slot2 UV Interleave	23 - 4
MCR20: Slot3 UV Interleave Data Source	23 - 4
MCR24: Y Data Source Line Offset	23 - 4
MCR28: UV Interleave Data Source Line Offset	23 - 5

Motion Comp Bus Master CMD Control Registers**MCR00: Motion Comp Enable**

Read/Write Address: MCR_Base + Offset

Power-On Default:

7	6	5	4	3	2	1	0
RESERVED							MCE

Bit 7:1 Reserved**Bit 0** Motion Comp Enable (MCE)**MCR04: Slot 0 Y Data Source**

Read/Write Address: MCR_Base + Offset

Power-On Default:

31	30	29	28	27	26	25	24	23	22	21	20	19	18	17	16
RESERVED											SLOT0 Y DATA				
15	14	13	12	11	10	9	8	7	6	5	4	3	2	1	0
SLOT0 Y DATA															

Bit 31:20 Reserved**Bit 19:0** Slot0, Y Data Source Starting Address**MCR08: Slot1 Y Data Source**

Read/Write Address: MCR_Base + Offset

Power-On Default:

31	30	29	28	27	26	25	24	23	22	21	20	19	18	17	16
RESERVED											SLOT1 Y DATA				
15	14	13	12	11	10	9	8	7	6	5	4	3	2	1	0
SLOT1 Y DATA															

Bit 31:20 Reserved**Bit 19:0** Slot1, Y Data Source Starting Address**MCR0C: Slot2 Y Data Source**

Read/Write Address: MCR_Base + Offset

Power-On Default:

31	30	29	28	27	26	25	24	23	22	21	20	19	18	17	16
RESERVED											SLOT2 Y DATA				
15	14	13	12	11	10	9	8	7	6	5	4	3	2	1	0
SLOT2 Y DATA															

Bit 31:20 Reserved**Bit 19:0** Slot2, Y Data Source Starting Address**MCR10: Slot3 Y Data Source**

Read/Write Address: MCR_Base + Offset

Power-On Default:

31	30	29	28	27	26	25	24	23	22	21	20	19	18	17	16
RESERVED											SLOT3 Y DATA				
15	14	13	12	11	10	9	8	7	6	5	4	3	2	1	0
SLOT3 Y DATA															

Bit 31:20 Reserved**Bit 19:0** Slot3, Y Data Source Starting Address**MCR14: Slot0 UV Interleave Data Source**

Read/Write Address: MCR_Base + Offset

Power-On Default:

31	30	29	28	27	26	25	24	23	22	21	20	19	18	17	16
RESERVED											SLOT0 UV INTERLEAVE				
15	14	13	12	11	10	9	8	7	6	5	4	3	2	1	0
SLOT0 UV INTERLEAVE															

Bit 31:20 Reserved**Bit 19:0** Slot0, UV Interleave Data Source Starting Address**MCR18: Slot1 UV Interleave Data Source**

Read/Write Address: MCR_Base + Offset

Power-On Default:

31	30	29	28	27	26	25	24	23	22	21	20	19	18	17	16
RESERVED												SLOT1 UV INTERLEAVE			
15	14	13	12	11	10	9	8	7	6	5	4	3	2	1	0
SLOT1 UV INTERLEAVE															

Bit 31:20 Reserved

Bit 19:0 Slot1, UV Interleave Data Source Starting Address

MCR1C: Slot2 UV Interleave

Read/Write Address: MCR_Base + Offset

Power-On Default:

31	30	29	28	27	26	25	24	23	22	21	20	19	18	17	16
RESERVED												SLOT2 UV INTERLEAVE			
15	14	13	12	11	10	9	8	7	6	5	4	3	2	1	0
SLOT2 UV INTERLEAVE															

Bit 31:20 Reserved

Bit 19:0 Slot2, UV Interleave Data Source Starting Address

MCR20: Slot3 UV Interleave Data Source

Read/Write Address: MCR_Base + Offset

Power-On Default:

31	30	29	28	27	26	25	24	23	22	21	20	19	18	17	16
RESERVED												SLOT3 UV INTERLEAVE			
15	14	13	12	11	10	9	8	7	6	5	4	3	2	1	0
SLOT3 UV INTERLEAVE															

Bit 31:20 Reserved

Bit 19:0 Slot3, UV Interleave Data Source Starting Address

MCR24: Y Data Source Line Offset

Read/Write Address: MCR_Base + Offset

Power-On Default:

7	6	5	4	3	2	1	0
OFFSET							

Bit 8:0 Y Data Source Line Offset (row pitch)

MCR28: UV Interleave Data Source Line Offset

Read/Write Address: MCR_Base + Offset

Power-On Default:

7	6	5	4	3	2	1	0
UV INTERLEAVE DATA SOURCE LINE OFFSET							

Bit 8:0 UV Interleave Data Source Line Offset (row pitch)

Chapter 24: PCI Bus Master Control Registers

Table 30: PCI Bus Master Control Registers Quick Reference

Summary of Registers	Page
<i>Motion Compensation ICMD Control Registers</i>	
Table of Entry Register	24 - 2
Physical Address Register	24 - 2
Blocksize Register	24 - 2
Entire Transfer Size of 32-Bit Data	24 - 3
Transfer Size Remaining	24 - 3
<i>Motion Compensation IDCT Control Registers</i>	
Table of Entry Register	24 - 4
Physical Address Register	24 - 4
Blocksize Register	24 - 4
Entire Transfer Size of 32-Bit Data	24 - 5
Transfer Size Remaining	24 - 5
<i>Host Master Control Registers</i>	
Table of Entry Register	24 - 5
Physical Address Register	24 - 6
Blocksize Register	24 - 6
Entire Transfer Size of 32-Bit Data	24 - 7
Transfer Size Remaining	24 - 7
Starting Address	24 - 7
Width and Offset	24 - 8
Plane Selection	24 - 8
<i>Texture 3D Bus Master Control Registers</i>	
Table of Entry Register	24 - 9
Physical Address Register	24 - 9
Blocksize Register	24 - 9
Entire Transfer Size of 32-Bit Data	24 - 10
Transfer Size Remaining	24 - 10

Motion Compensation ICMD Control Registers**Table of Entry Register**

Read/Write Address: ICMD_Reg_Base + Offset

Offset 0:

Power-on Default: XXh

31	30	29	28	27	26	25	24	23	22	21	20	19	18	17	16
TABLE OF ENTRY															
15	14	13	12	11	10	9	8	7	6	5	4	3	2	1	0
TABLE OF ENTRY														DC	LL

Bit 31:2 Table of Entry Address**Bit 1** Don't Care (DC)

Bit 0 Link List Bit (LL)
 1 = more table of entries
 0 = end of table of entry

Physical Address Register

Read/Write Address: ICMD_Reg_Base + Offset

Offset 4:

Power-on Default: XXh

31	30	29	28	27	26	25	24	23	22	21	20	19	18	17	16
PHYSICAL DATA MEMORY															
15	14	13	12	11	10	9	8	7	6	5	4	3	2	1	0
PHYSICAL DATA MEMORY														DON'T CARE	

Bit 31:2 Physical Data Memory Address**Bit 1:0** Don't Care**Blocksize Register**

Read/Write Address: ICMD_Reg_Base + Offset

Offset 8:

Power-on Default: XXh

31	30	29	28	27	26	25	24	23	22	21	20	19	18	17	16
READ ONLY															
15	14	13	12	11	10	9	8	7	6	5	4	3	2	1	0
BLOCK SIZE															

Bit 31:16 Read Only

Bit 15:0 Block size

Entire Transfer Size of 32-Bit Data

Read/Write Address: ICMD_Reg_Base + Offset

Offset C:

Power-on Default: 00h

31	30	29	28	27	26	25	24	23	22	21	20	19	18	17	16
EMI	PMD	DON'T CARE												ETS	
15	14	13	12	11	10	9	8	7	6	5	4	3	2	1	0
ETS															

Bit 31 Enable Master Interface (EMI)

Bit 30 Use of physical memory data address instead of table entry address during master request phase (PMD)

Bit 29:18 Don't Care

Bit 17:0 Entire Transfer Size (ETS)

Transfer Size Remaining

Read/Write Address: ICMD_Reg_Base + Offset

Offset 10: Read Only

Power-on Default: XXh

31	30	29	28	27	26	25	24	23	22	21	20	19	18	17	16
DON'T CARE														RTS	
15	14	13	12	11	10	9	8	7	6	5	4	3	2	1	0
RTS															

Bit 31:18 Don't Care

Bit 17:0 Remaining transfer size including all blocks (RTS)

Motion Compensation IDCT Control Registers**Table of Entry Register**

Read/Write Address: IDCT_Reg_Base + Offset

Offset 0:

Power-on Default: XXh

31	30	29	28	27	26	25	24	23	22	21	20	19	18	17	16
TABLE OF ENTRY															
15	14	13	12	11	10	9	8	7	6	5	4	3	2	1	0
TABLE OF ENTRY														DC	LL

Bit 31:2 Table of Entry Address**Bit 1** Don't Care (DC)

Bit 0 Link List Bit (LL)
 1 = more table of entries
 0 = end of table of entry

Physical Address Register

Read/Write Address: IDCT_Reg_Base + Offset

Offset 4:

Power-on Default: XXh

31	30	29	28	27	26	25	24	23	22	21	20	19	18	17	16
PHYSICAL DATA MEMORY															
15	14	13	12	11	10	9	8	7	6	5	4	3	2	1	0
PHYSICAL DATA MEMORY														DON'T CARE	

Bit 31:2 Physical Data Memory Address**Bit 1:0** Don't Care**Blocksize Register**

Read/Write Address: IDCT_Reg_Base + Offset

Offset 8:

Power-on Default: XXh

31	30	29	28	27	26	25	24	23	22	21	20	19	18	17	16
READ ONLY															
15	14	13	12	11	10	9	8	7	6	5	4	3	2	1	0
BLOCK SIZE															

Bit 31:16 Read Only

Bit 15:0 Block size

Entire Transfer Size of 32-Bit Data

Read/Write Address: IDCT_Reg_Base + Offset

Offset C:

Power-on Default: 00h

31	30	29	28	27	26	25	24	23	22	21	20	19	18	17	16
EMI	PMD	DON'T CARE												ETS	
15	14	13	12	11	10	9	8	7	6	5	4	3	2	1	0
ETS															

Bit 31 Enable Master Interface (EMI)

Bit 30 Use of physical memory data address instead of table entry address during master request phase (PMD)

Bit 29:18 Don't Care

Bit 17:0 Entire Transfer Size (ETS)

Transfer Size Remaining

Read/Write Address: IDCT_Reg_Base + Offset

Offset 10: Read Only

Power-on Default: XXh

31	30	29	28	27	26	25	24	23	22	21	20	19	18	17	16
DON'T CARE														RTS	
15	14	13	12	11	10	9	8	7	6	5	4	3	2	1	0
RTS															

Bit 31:18 Don't Care

Bit 17:0 Remaining transfer size including all blocks (RTS)

Host Master Control Registers**Table of Entry Register**

Read/Write Address: Host Master Control_Reg_Base + Offset

Offset 0:

Power-on Default: XXh

31	30	29	28	27	26	25	24	23	22	21	20	19	18	17	16
TABLE OF ENTRY															
15	14	13	12	11	10	9	8	7	6	5	4	3	2	1	0
TABLE OF ENTRY														DC	LL

Bit 31:2 Table of Entry Address**Bit 1** Don't Care (DC)

Bit 0 Link List Bit (LL)
 1 = more table of entries
 0 = end of table of entry

Physical Address Register

Read/Write Address: Host Master Control_Reg_Base + Offset

Offset 4:

Power-on Default: XXh

31	30	29	28	27	26	25	24	23	22	21	20	19	18	17	16
PHYSICAL DATA MEMORY															
15	14	13	12	11	10	9	8	7	6	5	4	3	2	1	0
PHYSICAL DATA MEMORY														DON'T CARE	

Bit 31:2 Physical Data Memory Address**Bit 1:0** Don't Care**Blocksize Register**

Read/Write Address: Host Master Control_Reg_Base + Offset

Offset 8:

Power-on Default: XXh

31	30	29	28	27	26	25	24	23	22	21	20	19	18	17	16
READ ONLY															
15	14	13	12	11	10	9	8	7	6	5	4	3	2	1	0
BLOCK SIZE															

Bit 31:16 Read Only

Bit 15:0 Block size

Entire Transfer Size of 32-Bit Data

Read/Write Address: Host Master Control_Reg_Base + Offset

Offset C:

Power-on Default: 00h

31	30	29	28	27	26	25	24	23	22	21	20	19	18	17	16
EMI	PMD	DON'T CARE												ETS	
15	14	13	12	11	10	9	8	7	6	5	4	3	2	1	0
ETS															

Bit 31 Enable Master Interface (EMI)

Bit 30 Use of physical memory data address instead of table entry address during master request phase (PMD)

Bit 29:18 Don't Care

Bit 17:0 Entire Transfer Size (ETS)

Transfer Size Remaining

Read/Write Address: Host Master Control_Reg_Base + Offset

Offset 10: Read Only

Power-on Default: XXh

31	30	29	28	27	26	25	24	23	22	21	20	19	18	17	16
DON'T CARE														RTS	
15	14	13	12	11	10	9	8	7	6	5	4	3	2	1	0
RTS															

Bit 31:18 Don't Care

Bit 17:0 Remaining transfer size including all blocks (RTS)Motion Compensation ICMD Control Registers

Starting Address

Read/Write Address: Host Master Control_Reg_Base + Offset

Offset 14:

Power-on Default: Undefined

31	30	29	28	27	26	25	24	23	22	21	20	19	18	17	16
RESERVED												STARTING ADDRESS			
15	14	13	12	11	10	9	8	7	6	5	4	3	2	1	0
STARTING ADDRESS															

Bit 31:20 Reserved**Bit 19:0** Starting Address for Master Transfer**Width and Offset**

Read/Write Address: Host Master Control_Reg_Base + Offset

Offset 18:

Power-on Default: Undefined

31	30	29	28	27	26	25	24	23	22	21	20	19	18	17	16
RESERVED						WIDTH FOR MASTER TRANSFER									
15	14	13	12	11	10	9	8	7	6	5	4	3	2	1	0
RESERVED						OFFSET FOR MASTER TRANSFER									

Bit 31:26 Reserved**Bit 25:16** Width for Master Transfer**Bit 15:10** Reserved**Bit 9:0** Offset for Master Transfer**Plane Selection**

Read/Write Address: Host Master Control_Reg_Base + Offset

Offset 1C:

Power-on Default: 00

31	30	29	28	27	26	25	24	23	22	21	20	19	18	17	16
RESERVED															
15	14	13	12	11	10	9	8	7	6	5	4	3	2	1	0
RESERVED													EY	EU	EV

Bit 31:3	Reserved
Bit 2	Enable Y-Plane Transfer
Bit 1	Enable U-Plane Transfer
Bit 0	Enable V Plane Transfer

Texture 3D Bus Master Control Registers

Table of Entry Register

Read/Write Address: Text3D_Reg_Base + Offset
 Offset 0:
 Power-on Default: XXh

31	30	29	28	27	26	25	24	23	22	21	20	19	18	17	16
TABLE OF ENTRY															
15	14	13	12	11	10	9	8	7	6	5	4	3	2	1	0
TABLE OF ENTRY														DC	LL

Bit 31:2 Table of Entry Address

Bit 1 Don't Care (DC)

Bit 0 Link List Bit (LL)
 1 = more table of entries
 0 = end of table of entry

Physical Address Register

Read/Write Address: Text3D_Reg_Base + Offset
 Offset 4:
 Power-on Default: XXh

31	30	29	28	27	26	25	24	23	22	21	20	19	18	17	16
PHYSICAL DATA MEMORY															
15	14	13	12	11	10	9	8	7	6	5	4	3	2	1	0
PHYSICAL DATA MEMORY														DON'T CARE	

Bit 31:2 Physical Data Memory Address

Bit 1:0 Don't Care

Blocksize Register

Read/Write Address: Text3D_Reg_Base + Offset

Offset 8:

Power-on Default: XXh

31	30	29	28	27	26	25	24	23	22	21	20	19	18	17	16
READ ONLY															
15	14	13	12	11	10	9	8	7	6	5	4	3	2	1	0
BLOCK SIZE															

Bit 31:16 Read Only**Bit 15:0** Block size**Entire Transfer Size of 32-Bit Data**

Read/Write Address: Text3D_Reg_Base + Offset

Offset C:

Power-on Default: 00h

31	30	29	28	27	26	25	24	23	22	21	20	19	18	17	16
EMI	PMD	DON'T CARE												ETS	
15	14	13	12	11	10	9	8	7	6	5	4	3	2	1	0
ETS															

Bit 31 Enable Master Interface (EMI)**Bit 30** Use of physical memory data address instead of table entry address during master request phase (PMD)**Bit 29:18** Don't Care**Bit 17:0** Entire Transfer Size (ETS)**Transfer Size Remaining**

Read/Write Address: Text3D_Reg_Base + Offset

Offset 10: Read Only

Power-on Default: XXh

31	30	29	28	27	26	25	24	23	22	21	20	19	18	17	16
DON'T CARE														RTS	
15	14	13	12	11	10	9	8	7	6	5	4	3	2	1	0
RTS															

Bit 31:18 Don't Care

Bit 17:0 Remaining transfer size including all blocks (RTS)

Chapter 25: 3D Registers

Table 31: Summary of Registers

Address	Description	Format
All Registers are 32-bit		
<i>3D Control Registers</i>		
DPR80	Reserved	
DPR84	Reserved	
DPR88	Reserved	
DPR8C	Reserved	
DPR90	Reserved	
DPR94 [15:0]	Z Initial Value	
DPR98	Reserved	
DPR9C [15:8]	Alfa_test	
DPR9C [7:0]	Morph A	
DPRA0 [23:0]	Dest_Comp_Color	R, G, B
DPRA4 [23:0]	Dest_CC Mask	
DPRA8 [23:0]	SRC_CC Mask	
DPRAC	Reserved	
DPRB0	Reserved	
DPRB4	Reserved	
DPRB8	Reserved	
DPRBC [23:0]	Text2 Blend Mode*	
DPRC0 [31]	Texture2 AGP Memory	
DPRC0 [30:28]	Reserved	
DPRC0 [27:0]	Texture2 Base Addr	*
DPRC4 [21:0]	3D Display Addr	Quad Word Address
DPRC8 [23:0]	Text1 Blend Mode	
DPRCC [31]	Texture1 AGP Memory	

Table 31: Summary of Registers (Continued)

Address	Description	Format
All Registers are 32-bit		
DPRCC [30]	Flush Cache	
DPRCC [29:28]	Reserved	
DPRCC [27:0]	Texture1 Base Addr	
DPRD0 [31:22]	Reserved	
DPRD0 [21:0]	Z_Base Address	
DPRD4 [21:0]	FB_Base	
DPRD8 [27:16]	3D fb_stride	
DPRD8 [11:0]	Z_stride *	
DPRDC [31:0]	3D_Cmd_Set_0	
DPRE0 [31:0]	3D_Cmd_Set_1	
DPRE4 [31:0]	3D_Cmd_Set_2	
DPRE8 [23:0]	Src_comp_color	R, G, B
DPREC [23:0]	Fog_color	R, G, B
DPRF0	Reserved	
DPRF4 [23:0]	Reserved	
DPRF8 [31:0]	Reserved	
DPRFC [31:0]	3D Test CMD	
<i>D3D Vertex Registers</i>		
DPR100 [31:0]	X0	iEEE S1E8M23
DPR104 [31:0]	Y0	iEEE S1E8M23
DPR108 [31:0]	Z0	iEEE S1E8M23
DPR10C [31:0]	Wi0	iEEE S1E8M23
DPR110 [31:0]	Cd ₀	ARGB8888
DPR114 [31:0]	Cs ₁	ARGB8888
DPR118 [31:0]	Swi0	iEEE S1E8M23
DPR11C [31:0]	Twi0	iEEE S1E8M23
DPR120 [10:0]	Go_0	

Table 31: Summary of Registers (Continued)

Address	Description	Format
All Registers are 32-bit		
DPR124 [31:0]	X1	iEEE S1E8M23
DPR128 [31:0]	Y1	iEEE S1E8M23
DPR12C [31:0]	Z1	iEEE S1E8M23
DPR130 [31:0]	Wi1	iEEE S1E8M23
DPR134 [31:0]	Cd ₁	ARGB8888
DPR138 [10:0]	Cs ₁	ARGB8888
DPR13C [31:0]	Swi1	iEEE S1E8M23
DPR140 [31:0]	Twi1	iEEE S1E8M23
DPR144 [10:0]	Go_1	
DPR148 [31:0]	X2	iEEE S1E8M23
DPR14C [31:0]	Y2	iEEE S1E8M23
DPR150 [31:0]	Z2	iEEE S1E8M23
DPR154 [31:0]	Wi2	iEEE S1E8M23
DPR158 [31:0]	Cd ₂	ARGB8888
DPR15C [31:0]	Cs ₂	ARGB8888
DPR160 [31:0]	Swi1	iEEE S1E8M23
DPR164 [31:0]	Twi2	iEEE S1E8M23
DPR168 [10:0]	Go_2	
DPR184	Reserved	
DPR188	Reserved	
DPR18C	Reserved	
<i>Open GL Vertex Registers</i>		
DPR100 [31:0]	X0	iEEE S1E8M23
DPR104 [31:0]	Y0	iEEE S1E8M23
DPR108 [31:0]	Z0	iEEE S1E8M23
DPR10C [31:0]	Wi0	iEEE S1E8M23
DPR110 [31:0]	R0	iEEE S1E8M23
DPR114 [31:0]	G0	iEEE S1E8M23
DPR118 [31:0]	B0	iEEE S1E8M23
DPR11C [31:0]	A0	iEEE S1E8M23
DPR120 [31:0]	Swi0	iEEE S1E8M23
DPR124 [31:0]	Twi0	iEEE S1E8M23
DPR128 [31:0]	Rs0	
DPR12C [31:0]	Gs0	iEEE S1E8M23
DPR130 [31:0]	Bs0	iEEE S1E8M23

Table 31: Summary of Registers (Continued)

Address	Description	Format
All Registers are 32-bit		
DPR134 [31:0]	As0	iEEE S1E8M23
DPR138 [10:0]	Go_0	iEEE S1E8M23
DPR140 [31:0]	X1	iEEE S1E8M23
DPR144 [31:0]	Y1	iEEE S1E8M23
DPR148 [31:0]	Z1	iEEE S1E8M23
DPR14C [31:0]	Wi1	iEEE S1E8M23
DPR150 [31:0]	R1	iEEE S1E8M23
DPR154 [12:0]	G1	
DPR158 [31:0]	B1	iEEE S1E8M23
DPR15C [31:0]	A1	iEEE S1E8M23
DPR160 [31:0]	Swi1	iEEE S1E8M23
DPR164 [10:0]	Twi1	iEEE S1E8M23
DPR168 [31:0]	Rs1	iEEE S1E8M23
DPR16C [31:0]	Gs1	iEEE S1E8M23
DPR170 [31:0]	Bs1	iEEE S1E8M23
DPR174 [31:0]	As1	iEEE S1E8M23
DPR178 [31:0]	G0_1	iEEE S1E8M23
DPR17C [31:0]	Twi2	iEEE S1E8M23
DPR180 [31:0]	X2	
DPR184 [31:0]	Y2	
DPR188 [31:0]	Z2	
DPR18C [31:0]	Wi2	
DPR190 [31:0]	R2	
DPR194 [31:0]	G2	
DPR198 [31:0]	B2	
DPR19C [31:0]	A2	
DPR1A0 [31:0]	Swi2	
DPR1A4 [31:0]	Twi2	
DPR1A8 [31:0]	Rs1	
DPR1AC [31:0]	Gs1	
DPR1B0 [31:0]	Bs1	
DPR1B4 [31:0]	As1	
DPR1B8 [31:0]	Go_2	
<i>Rendering Registers</i>		
DPR200 [23:0]	Xstart	S11.12

Table 31: Summary of Registers (Continued)

Address	Description	Format
All Registers are 32-bit		
DPR204 [23:0]	Xend1	S11.12
DPR208 [23:0]	Xend2	S11.12
DPR20C [10:0]	Ystart	11.0
DPR210 [11:0]	cnt1	
DPR214 [11:0]	cnt2	
DPR218 [23:0]	dXdY0	S11.12
DPR21C [23:0]	dXdY1	S11.12
DPR220 [23:0]	dXdy2	S11.12
DPR224 [9:0]	Xincr1	10.0
DPR228 [15:0]	rstart	S8.7
DPR22C [15:0]	gstart	S8.7
DPR230 [15:0]	bstart	S8.7
DPR234 [15:0]	drdx	S8.7
DPR238 [15:0]	dgdX	S8.7
DPR23C [15:0]	dbdx	S8.7
DPR240 [15:0]	drd1	S8.7
DPR244 [15:0]	dgd1	S8.7
DPR248 [15:0]	dbd1	S8.7
DPR24C [31:0]	zstart	S15.16
DPR250 [15:0]	astart	S8.7
DPR254 [15:0]	fstart	S8.7
DPR258 [31:0]	dzdx	S15.16
DPR25C [15:0]	dadx	S8.7
DPR260 [15:0]	sfdx	S8.7
DPR264 [31:0]	dzd1	S15.16
DPR268 [15:0]	dad1	S8.7
DPR26C [15:0]	sdfd1	S8.7
DPR270 [31:0]	sstart	S19.12
DPR274 [31:0]	tstart	S19.12
DPR278 [26:0]	wstart	S6.20
DPR27C [31:0]	dSDx	S19.12
DPR280 [31:0]	dtDx	S19.12
DPR284 [26:0]	dWdx	S6.20
DPR288 [31:0]	dSD1	S19.12
DPR28C [31:0]	dtD1	S19.12

Table 31: Summary of Registers (Continued)

Address	Description	Format
All Registers are 32-bit		
DPR290 [26:0]	dwd1	S6.20
DPR294 [31:0]	dSdy	S19.12
DPR298 [31:0]	dtDy	S19.12
DPR29C [26:0]	dWdy	S6.20
DPR2A0 [15:0]	srstart	S8.7 Specular
DPR2A4 [15:0]	sgstart	S8.7 Specular
DPR2A8 [15:0]	sbstart	S8.7 Specular
DPR2AC [15:0]	sdrdx	S8.7 Specular
DPR2B0 [15:0]	sdgdx	S8.7 Specular
DPR2B4 [15:0]	sdbdx	S8.7 Specular
DPR2B8 [15:0]	sdrd1	S8.7 Specular
DPR2BC [15:0]	sdgd1	S8.7 Specular
DPR2C0 [15:0]	sdbd1	S8.7 Specular
DPR2C4	Reserved	
DPR2C8	Reserved	
DPR2CC	Reserved	
DPR2D0	Reserved	
DPR2D4	Reserved	
DPR2D8	Reserved	
DPR2DC	Reserved	
DPR2E0	Reserved	
DPR2E4	Reserved	
DPR2E8	Reserved	
DPR2EC	Reserved	
DPR2F0	Reserved	
DPR2F4	Reserved	
DPR2F8	Reserved	
DPR2FC [31]	GO_L2R (when writing to this register EW is activated, 0: R2L, 1:L2R)	
<i>Global Fog Factor - Look-up Table (512 x 8)</i>		
DPR300 [31:0]	Fog3210	
.....		
DPR4FC [31:0]	Last 4 Fog	

Note:A.The Global fog space lookup table RAM will be shared for:

1. Global fog as 512x8 LUT
 2. 256x16 texture palette
- B. There are 2 sources that can write to the LUT
1. CPU through Write Buffer to LUT
- C. The RAM's write port could be 32-bit (from host) and read is 64-bit. There is flip-flop at input and output. At the 64-bit output, the palette will use index bit [2:1] to select the right 16-bit data, and for the fog the index bit [0] to select the right byte as fog factor.
- D. 3D command set bit [31:30] will select 8 bits out from Z's 16-bit
- 00:Z [15:8] as index for fog LUT-default
 - 01:Z [11:4] as index for fog LUT-default
 - 10:Z [7:0] as index for fog LUT-default

Table 32: 3D Registers Quick Reference

Summary of Registers	Page
3D_Command_Set_0	25 - 5
3D_Command_Set_1	25 - 6
3D_Command_Set_2	25 - 9
3D_Test Command	25 - 10
Go Register in Vertex	25 - 11
Z Base Register	25 - 12
Texture1 Base Register	25 - 13
Texture2 Base Register*	25 - 13
Texture1 Blending Mode	25 - 14
Table of Entry Address	25 - 16
DMA Physical Address	25 - 16
DMA Block Size/Page Size	25 - 17
DMA Total Transfer Size of 64-Bit Data	25 - 17

3D_Command_Set_0

Read Write Address: 0DCh

Power-on Default: 0h

31	30	29	28	27	26	25	24	23	22	21	20	19	18	17	16
MFE	Z BUFFER			ZUE	ZE	ME	TE	MLF	RESERVED					TEXTURE 1	
15	14	13	12	11	10	9	8	7	6	5	4	3	2	1	0
TEXTURE 0		TFM			TCF			TEXTURE SIZE							

- Bit 31** Magnification Filter Enable* (MFE)
0 = magnification filter same as texture filter mode
1 = magnification filter use CMD0 [23]
- Bit 30:28** Z Buffer Compare Mode
000 = Z never pass
001 = pass if $Z_i > Z_{zb}$
010 = pass if $Z_i = Z_{zb}$
011 = pass if $Z_i \geq Z_{zb}$
100 = pass if $Z_i < Z_{zb}$
101 = pass if $Z_i \neq Z_{zb}$
110 = pass if $Z_i \leq Z_{zb}$
111 = Z always passes
- Bit 27** Z Update Enable (ZUE)
0 = do not update Z buffer
1 = update z-buffer with new pixel z value if z compare pass
Z is 16Bit per pixel same as MS D3D. This Bit valid only when Z is enable
- Bit 26** Z Enable (ZE)
0 = Z buffer disable - no hardware Z fetch and compare
1 = Z buffer enable
- Bit 25** Mipmap Enable (ME)
0: single map texture
1: mipmap texture
- Bit 24** Texture Enable (TE)
0 = Texture mapping off
1 = Texture mapping on
- Bit 23** Magnification Linear Filter* (MLF)
0 = Nearest for magnification map
1 = Linear (Bilinear) for magnification map
This bit is valid only when the magnification filter is enabled (CMD0 [31] =1)
- Bit 22:18** Reserved

Bit 17:16 Texture 2 Address Mode*
 00 = NONE use texture border color for outside range
 01 = D3DTADDR_WRAP: wrapping around both U and V coordinate
 10 = D3DTADDR_CLAMP: Max (u,v) = 1.0. Min (u,v) = 0.0
 11 = DEDTADDR_MIRROR: 1.1 becomes .9, 1.7 becomes .3
 2.2 becomes .2 and 2.8 becomes .8

Bit 15:14 Texture 1 Address Modes
 00 = NONE use texture border color for outside range
 01 = D3DTADDR_WRAP: wrapping around both U and V coordinate
 10 = D3DTADDR_CLAMP: Max (u,v) = 1.0. Min (u,v) = 0.0
 11 = DEDTADDR_MIRROR: 1.1 becomes .9, 1.7 becomes .3
 2.2 becomes .2 and 2.8 becomes .8

Bit 13:11 Texture Filtering Modes (TFM)
 000 = D3DFILTER_NEAREST:PS point sampling of texture = floor(u,v)
 001 = D3DFILTER_LINEAR: BL bilinear filtering
 010 = D3DFILTER_MIPNEAREST: NMN 1 mipmap + pointsample
 011 = D3DFILTER_LINEAR_MIPNEAREST: NML bilinear on selected mipmap
 100 = D3DFILTER_MIPLINEAR: LMN linear on 2 mipmap's nearest
 101 = D3DFILTER_LINEARMIPLINEAR: LML trilinear
 (110) = Reserved
 111 = Reserved

Bit 10:8 Texture Color Format (TCF)
 000 = ARGB8888
 001 = ARGB4444
 010 = ARGB1555
 011 = YUYV16/RGB565
 100 = CI8
 101 = Compress Texture DXT1
 110 = Compress Texture DXT2
 111 = Compress Texture DXT3

Bit 7:0 Texture1 Size. 2**m X 2**n is the largest mipmap texture rectangular
 7:4 = m. where 2**m is the dimension x of rectangular texture
 3:0 = n. where 2**n is the dimension y of rectangular

3D_Command_Set_1

Read Write Address: 0E0h
 Power-on Default: 0h

31	30	29	28	27	26	25	24	23	22	21	20	19	18	17	16
OGL	PSR	DSE	RESERVED		SO	DE	DMAC		FP PIXEL		RESERVED		GLOBAL FOG		FC
15	14	13	12	11	10	9	8	7	6	5	4	3	2	1	0
FC	CKP	TFM	DESTINATION BLENDING				SOURCE BLEND				ABE	R	3D DRAW		

- Bit 31** Open GL/D3D Vertex selection (OGL)
This Bit to determine the vertex address either in D3D space or OpenGL space as shown in the vertex registers table
0 = D3D vertex address mode
1 = OpenGL vertex address mode
- Bit 30** Point Sample Round Up for texture mapping (PSR)
0: Floor on S, T- current MicroSoft D3D
1: Floor on S +.5, T +.5;
- Bit 29** Disable Setup Engine (DSE)
0 = Enable setup (default)
1 = Reset setup engine: for SU by pass and vertex or render registers read
- Bit 28:27** Reserved
- Bit 26** Specular On (SO)
0 = Specular off
1 = Specular on
- Bit 25** Dither Enable. This Bit to add dithering to internal 24-bit to 16-bit color conversion. (DE)
0: Dither off
1: Dither on
- Bit 24:23** DMA Control (DMAC)
00: 2D 3D command & DMA (default) - with mask header
01: Vertex DMA - group# and mask
10: MBit DMA - no mask for hbltw
11: Address, data pair DMA - no mask
- Notes: 1. When select Vertex DMA, internal vertex register will generate the vertex address and host address will be ignored. This Vertex DMA supports both master and slave mode for register write though hbltw port space
2. Vertex Register read also need to set the Vertex DMA bits, and CPU need to supply the Vertex address which means Slave mode only.
3. Before starting an vertex_DMA, this DMA control bit has to set to 00 because internal address counter rely on those two Bit to reset.
4. After finish the DMA transfer, this 2-bit register has to reset back to 00 or 2D engine would not work because 2D registers would not be decoded.
5. Refer to DMA Mask on Page 25 - 1 for details.
- Bit 22:21** FB Pixel Format
00: 565 RGB
01: 1555 ARGB
10: 8888 ARGB
11: Reserved
- Bit 20:19** Reserved
- Bit 18:17** Global Fog LUT index select (from Z):

	00&11:	Z_15:7 as global fog LUT index;
	01:	Z_12:4 "
	10:	Z_8:0"
Bit 16:15	Fog Control (FC) 0x = fog disable 10 = local fog(vertex fog) 11 = global fog	
Bit 14	Source Color Key Polarity (CKP) 0: inclusive transparent - within the color low and color high range transparent 1: exclusive transparent - outside the colow low and color high range transparent	
Bit 13	Source Color Key Transparency Enable (CKT) 0: Disable Color Key comparison. Pixel write enable 1: Enable Color Key comparison. Pixel write base on compared result. Note: This is texture color compare against compare color ergister (E8)	
Bit 12:9	Destination Blending Factors	
	0000: ZERO	(0, 0, 0, 0)
	0001: One	(1, 1, 1, 1)
	0010: SRC_COLOR	(Rs, Gs, Bs, As)
	0011: INV_SRC_COLOR	(1 - Rs, 1- Gs, 1 - Bs, 1 - As)
	0100: SRC_ALPHA	(As, As, As, As)
	0101: INV_SRC_ALPHA	(1 - As, 1 - As, 1 - As,1 - As)
	0110: Dst_Alpha	(Ad, Ad, Ad, Ad)
	0111: INV_DST_ALPHA	(1- Ad, 1 - Ad, 1 - Ad, 1 - Ad)
	1000: DST_COLOR	(Rd, Gd, Bd, Ad)
	1001: INV_DST_COLOR	(1 - Rd, 1- Gd, 1 - Bd, 1 - Ad)
Bit 8:5	Source Blend Factors	
	0000: Zero	(0, 0, 0, 0)
	0001: One	(1, 1, 1, 1)
	0010: DST_COLOR	(Rd, Gd, Bd, Ad)
	0011: INV_DST_COLOR	(1 - Rd, 1- Gd, 1 - Bd, 1 - Ad)
	0100: SRC_ALPHA	(As, As, As, As)
	0101: INV_SRC_ALPHA	(1 - As, 1 - As, 1 - As,1 - As)
	0110: Dst_Alpha	(Ad, Ad, Ad, Ad)
	0111: INV_DST_ALPHA	(1- Ad, 1 - Ad, 1 - Ad, 1 - Ad)
	1000: SRC_ALPHA_SAT	(f, f, f, 1) where f = min(As, 1 - Ad)
	1001: SRC_COLOR	(Rs, Gs, Bs, As)
	1010: INV_SRC_COLOR	(1 - Rs, 1- Gs, 1 - Bs, 1 - As)
Bit 4	Alpha Blending Enable(Enable Source/Destination Blending) (ABE) 0 = Disable Alpha Blending. No Source/Destination blending 1 = Enable Alpha Blending	
Bit 3	Reserved (R)	
Bit 2:0	3D Draw Command	

000 = 3D Triangle; if flat and no Z, 2D will take the span data and do the span fill job.
 001 = 3D Line with Y major
 010 = 3D Line with X major
 - software needs to swap the vertex (X,Y) to (YX) before sending to SU, and the Edge Walker needs to swap back the (YX) to (XY) before sending to span.
 011 = 3D Point
 100 = Anti alias 3D Triangle;
 101 = Anti alias 3D Line with Y major
 110 = Anti alias 3D Line with X major
 - software needs to swap the vertex (X,Y) to (YX) before sending to SU, and the Edge Walker needs to swap back the (YX) to (XY) before sending to span or else reserved

3D_Command_Set_2

Read Write Address: 0E4h

Power-on Default: 0h

31	30	29	28	27	26	25	24	23	22	21	20	19	18	17	16	
Z	FZ	IZ	ZMAP	TEXTURE2 SIZE								CK	ALPHA TEST			
15	14	13	12	11	10	9	8	7	6	5	4	3	2	1	0	
RESERVED							LOD BIAS				LCE	LOD CLAMP LEVEL				

- Bit 31** Z with Sign bit (Z)
 0 = Z format is 16-bit positive value
 1 = Z is S15 (one sign plus 15 value) 16-bit 2's complement value
- Bit 30** Flush Z cache - one cycle pulse (FZ)
 Set this bit to 1 to flush the internal Z cache. Internal logic will set back to 0 for normal cache operation
 0 = Normal operation mode
 1 = Invalidate the cache
- Bit 29** Initialize Z - one cycle pulse (IZ)
 Set this bit to 1 to initial Z to Z value (R94) in null cycle. Internal logic will set this bit back to 0 for normal operation
 0 = Normal operation mode
 1 = Initialize Z to Z value at zero cycle
- Bit 28** Z-map bypass (ZMAP)
 0 = Normal zero cycle Z operation
 1 = Bypass zero cycle Z clear operation (need 2D to do Z clear)
- Bit 27:20** *Texture2 size - 2**m X52**n is the largest mipmap texture rectangular
 [23:20] = m - where 2**m is the dimension of X of rectangular texture
 [19:16] = n - where 2**n is the dimension Y of rectangular
- Bit 19** Destination color key transparency enable (CK)
 0 = Disable color key comparion. Pixel write enable
 1 = Enable color key comparison. Pixel write base on compared result.

Note: This is FB color compare against compare color register (A0)

Bit 18:16 Alpha Test Mode
 000 = Alpha always pass (similar to disable alpha test) - default
 001 = pass if $A_s > A_{ref}$
 010 = pass if $A_s = A_{ref}$
 011 = pass if $A_s \geq A_{ref}$
 100 = pass if $A_s < A_{ref}$
 101 = pass if $A_s \neq A_{ref}$
 110 = pass if $A_s \leq A_{ref}$
 111 = Alpha never passes
 Note: A_{ref} at register 9C_[15:8]

Bit 15:9 Reserved

Bit 8:5 LOD Bias - default 0
 Hardware LOD calculation will be offset by this register

Bit 4 LOD Clamp Enable (LCD)
 0 = No LOD clamp - normal operation
 1 = Maximum LOD level will be clamp at bit [3:0]

Bit 3:0 LOD Clamp Level - Valid only when bit [4] = 1
 Maximum LOD level that texture engine could reach.

3D_Test Command

Read Write Address: 0FCh
 Power-on Default: 0h

31	30	29	28	27	26	25	24	23	22	21	20	19	18	17	16
RESERVED															
15	14	13	12	11	10	9	8	7	6	5	4	3	2	1	0
RESERVED			PDA	CDA	R	FTE	FPE	FT	FD	FZ	R	SS	LS	IR	STE

Bit 31:13 Reserved

Bit 12 Select 3D display address as panel display address (PDA)
 0 = CRT normal display mode - use CRT_0C and CRT_0D as display address
 1 = Select 3D display address register (0C4h) as panel address

Bit 11 Select 3D display address as CRT display address (CDA)
 0 = CRT normal display mode - use CRT0C and CRT0D as display address
 1 = Select 3D display address register (0C4h) as CRT display address

Bit 10 Reserved (R)

Bit 9 Force triangle engine ready for both (FTE)

- 1. Accepting data from SU]
- 2. Span ready for pixel engine

- Bit 8** Force pixel engine ready for both (FPE)
 - 1. Accept span data
 - 2. Z and D for memory write

- Bit 7** Force texture ready in both to accept span data and data for filtering (FT)

- Bit 6** Force Destination ready in (FD)
 - 1. Accept span
 - 2. Ready for alpha blending
 - 3. Ready to write out the data to memory. Destination always ready when this bit is set to 1

- Bit 5** Force Z ready in both (FZ)
 - 1. Accept span
 - 2. Data ready for Z compare. Z is always ready when this bit is set to 1.

- Bit 4** Reserved (R)

- Bit 3** All seq used in setup (SS)
 - 0 = Skip according to which feature is on
 - 1 = All UC sequence will be executed no matter what features are on

- Bit 2** Latedone used in setup for debug purpose (LS)
 - 0 = New vertex data will be loaded whenever current vertex register is ready for next one
 - 1 = Vertex register will not load until last UC instruction is executed.

- Bit 1** Select internal rendering register B/A for read (IR)
 - 0 = Select rendering register A
 - 1 = Select rendering register B

- Bit 0** Stop triangle engine (for CPU read rendering register) (STE)
 - 0 = Normal operation mode
 - 1 = Stop triangle engine operation

This bit set to 1 will block the triangle engine from kickoff. All rendering registers would not be changed by triangle engine.

Go Register in Vertex

Read Write Address: 120, 144, and 168 in D3D vertex; 138, 178, and 188 in Open GL vertex
 Power-on Default: 0h

Note: This register is spread to 3 different locations, and is connected to the same physical register.

31	30	29	28	27	26	25	24	23	22	21	20	19	18	17	16	
RESERVED																
15	14	13	12	11	10	9	8	7	6	5	4	3	2	1	0	
RESERVED								PCO	TT	SHADING			FCS		IR	STE

Bit 31:8 Reserved

Bit 7 Perspective correction off (PCO)
0 = Perspective correction on
1 = Perspective correction off

Bit 6 Two Texture (TT)
0 = Single texture triangle
1 = Two texture triangle

Bit 5:4 Shading select
00: Gouraud
01: Flat
1X: Reserved

Bit 3:2 Flat color selection (FCS)
00: Vertex 0 diffuse color as flat color
01: Vertex 1 diffuse color as flat color
10: Vertex 2 diffuse color as flat color
11: Reserved (default vertex 0)

Bit 1 ALL_GO (AG)
0: reset to 0 by setup engine
1: active the setup engine
This bit set means all the vertex information have loaded into the vertex registers and is ready for Setup Engine to kickoff. This bit is reset by setup engine when setup read it or reach RE_GO.

Bit 0 XY_GO (XYG)
0: reset to 0 by setup engine
1: active the setup engine
This bit set means Vertex's XY coordinate has been loaded and Setup Engine is ok to kickoff. This bit is reset by setup engine when setup read it or reach RE_GO.

Z Base Register

Read Write Address: D0
Power-on Default: Don't care

31	30	29	28	27	26	25	24	23	22	21	20	19	18	17	16	
Z BUFFER		RESERVED									BASE ADDRESS					
15	14	13	12	11	10	9	8	7	6	5	4	3	2	1	0	
BASE ADDRESS																

Bit 31:30 Z Buffer
 0x = Local Z buffer
 10 = AGP Z buffer
 11 = PCI system Z buffer

Bit 29:22 Reserved

Bit 21:0 Base address in 64 bit as a unit (21 bit cover 32MB space)
 Note: write to this register will cause flush Z cache

Texture1 Base Register

Read Write Address: CC
 Power-on Default: FC [bit 30] = 0 , or else Don't Care

31	30	29	28	27	26	25	24	23	22	21	20	19	18	17	16
T1	FC	RESERVED			TEXTURE BASE ADDRESS										
15	14	13	12	11	10	9	8	7	6	5	4	3	2	1	0
TEXTURE BASE ADDRESS															

Bit 31 Texture1 in AGP memory: when this bit is set - texture1 is located at AGP memory. The physical address of AGP base is specified in bit [27:0] (T1)

Bit 30 Flush cache: when this bit is 1 - the internal cache will be reset. This bit 1 and new write to this register will generate a cache reset pulse. (FC)

Bit 29:28 Reserved

Bit 27:0 Texture base address in 128-bit (16-byte) as a unit (cover 4GB space)

Texture2 Base Register*

Read Write Address: C0
 Power-on Default: Don't Care

31	30	29	28	27	26	25	24	23	22	21	20	19	18	17	16
T2	RESERVED			TEXTURE BASE ADDRESS											
15	14	13	12	11	10	9	8	7	6	5	4	3	2	1	0
TEXTURE BASE ADDRESS															

Bit 31 Texture2 in AGP memory: when this bit is set - texture1 is located at AGP memory. The physical address of AGP base is in AGP physical address register (T2)

Bit 30:28 Reserved

Bit 27:0 Texture base address in 128-bit (16-byte) as a unit (cover 4GB space)

Texture1 Blending Mode

Read Write Address: C8

Power-on Default: 0h

31	30	29	28	27	26	25	24	23	22	21	20	19	18	17	16
RESERVED		ALPHA BLENDING MODE				AA1S			AA1C	AA1A	AA2S			AA2C	AA2A
15	14	13	12	11	10	9	8	7	6	5	4	3	2	1	0
RESERVED		CLOCK BLENDING MODE				CA1S			CA1C	CA1A	CA2S			CA1C	CA1A

Bit 31:30 Reserved

Bit 29:26 Alpha blending mode

0000: SELECT ARG1 //default

0001: SELECT ARG2

0010: MODULATE //multiply

0011: MODULATE2X //multiply and shift 1 bits

0100: MODULATE4X //multiply and shift 2 bits

0101: ADD //add arg2 together

0101: ADDSIGNED //add with -0.5 bias

 //***Linear alpha blend:

0111: BLENDDIFFUSEALPHA //alpha from diffuse alpha

1000: BLENDTEXTUREALPHA //alpha from texture alpha

1001: BLENDFACTORALPHA //alpha from morphing register

 //Linear alpha blend with pre-multiplied arg1 input: Arg1 = Arg2* (1-Alpha)

1010: BLENDTEXTUREALPHAM //texture alpha

else: reserved

Bit 25:23 Alpha argument 1 selection (AA1S)

000: diffuse alpha

001: specular alpha

010: texture alpha

011: select texture factor - morph alpha

	1xx: reserved
Bit 22	Alpha argument 1 complement (AA1C) 0 = non complement the input alpha 1 = invert the input alpha and color RGB
Bit 21	Alpha argument 1 alpha replicate (AA1A) 0 = color ocmponents no change 1 = repllicate alpha to color components
Bit 20:18	Alpha argument 2 selection (AA2S) 000: diffuse alpha 001: specular alpha 010: texture alpha 011: select texture factor - morph alpha 1xx: reserved
Bit 17	Alpha argument 2 complement (AA2C) 0 = non-complement the input alpha 1 = invert the input alpha and color RGB
Bit 16	Alpha argument 2 alpha replicate (AA2A) 0 = color components no change 1 = replicate alpha to color components
Bit 15:14	Reserved
Bit 13:10	Color blending mode 0000: SELECT ARG1 //default 0001: SELECT ARG2 0010: MODULATE //multiply 0011: MODULATE2X //multiply and shift 1 bits 0100: MODULATE4X //multiply and shift 2 bits 0101: ADD //add arg2 together 0110: ADDSIGNED //add with -0.5 bias //***Linear alpha blend: 0111: BLENDDIFFUSEALPHA //alpha from diffuse alpha 1000: BLENDTEXTUREALPHA //alpha from texture alpha 1001: BLENDFACTORALPHA //alpha from morphing register //Linear alpha blend with pre-multiplied arg1 input: Arg1 = Arg2* (1-Alpha) 1010: BLENDTEXTUREALPHAM //texture alpha else: reserved
Bit 9:7	Color argument 1 selection (CA1S) 000: diffuse color 001: specular color 010: texture color 011: select texture factor - diffuse color 1xx: reserved

- Bit 6** Color argument 1 complement (CA1C)
0 = non complement the input color
1 = invert the input color
- Bit 5** Color argument 1 alpha replicate (CA1A)
0 = color components no change
1 = replicate alpha to color components
- Bit 4:2** Color argument 2 selection (CA2S)
000: diffuse color
001: specular color
010: texture color
011: select texture factor - diffuse color
1xx: reserved
- Bit 1** Color argument 1 complement (CA1C)
0 = non complement the input color
1 = invert the input color
- Bit 0** Color argument 1 alpha replicate (CA1A)
0 = color components no change
1 = replicate alpha to color components

2D3D DMA Registers**Table of Entry Address**

Read Write Address: 3000

Power-on Default:

31	30	29	28	27	26	25	24	23	22	21	20	19	18	17	16
TABLE OF ENTRY ADDRESS															
15	14	13	12	11	10	9	8	7	6	5	4	3	2	1	0
TABLE OF ENTRY ADDRESS														RESERVED	

Bit 31:2 Table of entry address**Bit 1:0** Reserved (R)**DMA Physical Address**

Read Write Address: 3004

Power-on Default:

31	30	29	28	27	26	25	24	23	22	21	20	19	18	17	16
PHYSICAL DATA MEMORY ADDRESS															
15	14	13	12	11	10	9	8	7	6	5	4	3	2	1	0
PHYSICAL DATA MEMORY ADDRESS														DON'T CARE	

Bit 31:2 Physical data memory address

Bit 1:0 Don't care

DMA Block Size/Page Size

Read Write Address: 3008

Power-on Default:

31	30	29	28	27	26	25	24	23	22	21	20	19	18	17	16
PAGE SIZE REMAINING - READ ONLY															
15	14	13	12	11	10	9	8	7	6	5	4	3	2	1	0
PAGE SIZE - 64-BIT AS A UNIT SPACE															

Bit 31:16 Page size remaining - read only

Bit 1:0 Page size - 64-bit as a unit space

DMA Total Transfer Size of 64-Bit Data

Read Write Address: 300C

Power-on Default:

31	30	29	28	27	26	25	24	23	22	21	20	19	18	17	16
EMT	A	DON'T CARE												TTS	
15	14	13	12	11	10	9	8	7	6	5	4	3	2	1	0
TOTAL TRANSFER SIZE															

Bit 31 Enable master transfer (EMT)

Bit 30 Address (A)
0 = Use table of entry address
1 = Use Physical Address

Bit 29:18 Don't care

Bit 17:0 Total transfer size - maximum in double word transfer size 1MB (TTS)

Chapter 26: TV Encoder Registers

Table 33: TV Encoder Registers Quick Reference

Summary of Registers	Page
<i>Common Register</i>	
Mode Register	26 - 2
<i>Closed Captioning Registers</i>	
Closed Captioning Enable Register	26 - 2
Closed Captioning Line Number Register	26 - 3
Closed Captioning 1st and 2nd byte Data for Odd Field	26 - 3
Closed Captioning 1st and 2nd byte Data for Even Field	26 - 4
Closed Captioning Status Register	26 - 4

Register Descriptions

The following are the descriptions for each registers.

Common Register

Mode Register

Read/Write Address: 3?5h, Index: 60h
Power-on Default: 00h

This register controls main function as follows.

7	6	5	4	3	2	1	0
DON'T CARE		GL	OV	BL	VIDEO MODE		

Bit 7:6 Don't Care. These Bits are permanently set to logic 0

Bit 5 Genlock control (GL)
This Bit controls genlock On/Off. When the genlock is on, sub-carrier is aligned by the horizontal sync for every four or eight fields.
0: On
1: Off

Bit 4 Override control (OV)
This Bit switches the video mode select source.
0: Mode pins are selected
1: Mode register Bits are selected

Bit 3 Blank Level control (BL)
This Bit switches are the black setup level
0: Black level is 7.5 IRE
1: Black level is 0 IRE

Bit 2:0 Video Mode select
These Bits switch the video mode when (OV) is 1.
000: NTSC CCIR
001: NTSC Square Pixel
010: NTSC 4Fsc
100: PAL CCIR
101: PAL Square pixel

Closed Captioning Registers

Closed Captioning Enable Register

Read/Write Address: 3?5h, Index: 61h

Power-on Default: 00h

This register controls the closed captioning function On/Off as follows. If this function is enabled and a new data is not written (the field status is 1), a null data (80 hex) will be output.

7	6	5	4	3	2	1	0
DON'T CARE						CCE	

Bit 7:2 Don't Care. These Bits are permanently set to logic 0

Bit 1:0 Closed captioning enable (CCE)
 These Bits control the closed captioning On/Off for each field
 00: Disable
 01: Enable Odd field only
 10: Enable Even field only
 11: Enable both fields

Closed Captioning Line Number Register

Read/Write Address: 3?5h, Index: 62h

Power-on Default: 11h

This register controls closed captioning line number as follows:

7	6	5	4	3	2	1	0
DON'T CARE			CLOSED CAPTIONING LINE NUMBER				

Bit 7:5 Don't Care. These Bits are permanently set to logic 0

Bit 4:0 Closed Captioning Line Number Select
 These Bits set the line number for the closed captioning data.
 For NTSC mode, the actual line number will be CCL + 4 and CCL +263 +4
 For PAL mode, the actual line number will be CCL +1 and CCL + 313+1

Closed Captioning 1st and 2nd byte Data for Odd Field

Read/Write Address: 3?5h, Index: 63h

Power-on Default: 00h

7	6	5	4	3	2	1	0
CLOSED CAPTIONING 1st BYTE ODD FIELD							

Bit 7:0 Closed Captioning 1st Byte Odd Field

Read/Write Address: 64h

Power-on Default: 00h

7	6	5	4	3	2	1	0
CLOSED CAPTIONING 2nd BYTE ODD FIELD							

Bit 7:0 Closed Captioning 2nd Byte Odd Field

The value at Closed Captioning 1st byte will be output as a 1st closed captioning data of the odd filed. And the value at Closed Captioning 2nd byte will be output as a 2nd one. When one of these bytes is written, the odd status Bit OST will be cleared.

Closed Captioning 1st and 2nd byte Data for Even Field

Read/Write Address: 3?5h, Index: 65h
Power-on Default: 00h

7	6	5	4	3	2	1	0
CLOSED CAPTIONING 1st BYTE EVEN FIELD							

Bit 7:0 Closed Captioning 1st Byte Even Field

Read/Write Address: 66h
Power-on Default: 00h

7	6	5	4	3	2	1	0
CLOSED CAPTIONING 2nd BYTE EVEN FIELD							

Bit 7:0 Closed Captioning 2nd Byte Even Field

The value at Closed Captioning 1st byte will be output as a 1st closed captioning data of the even filed. And the value at Closed Captioning 2nd byte will be output as a 2nd one. When one of these bytes is written, the even status Bit EST will be cleared.

Closed Captioning Status Register

Read Only Address: 3?5h, Index: 67h
Power-on Default: 03h

This register shows the closed captioning status of each field. If these Bits are set to 1, existed data was sent out, and suitable for writing a new data to each closed captioning data registers. These Bits are cleared on new data writing for each field

7	6	5	4	3	2	1	0
DON'T CARE						OST	EST

Bit 7:2 Don't Care. These Bits are permanently set to logic 0

- Bit 1** Closed Captioning Odd field status (OST)
This Bit shows the odd field status. When set to 1, the data was sent out.
0: The data is not sent
1: The data is sent and ready for writing next data
- Bit 0** Closed Captioning Even Field Status (EST)
This Bit shows the even field status. When set to 1, the data was sent out.
0: The data is not sent
1: The data was sent and ready for writing next data.

Chapter 27: Electrical Specifications

Absolute Maximum Ratings

Table 34: Absolute Maximum Ratings

Specification	Maximum rating
Ambient temperature (TA)	0° C to 75° C
Storage temperature	-40° C to 125° C
Voltage on I/O pins with respect to VSS	- 0.5V to VDD + 5%
Operating power dissipation	TBD
Core DC Power supply voltage	2.5V ± 5%

Table 35: Recommended DC Operating Voltages

Supply Voltage	Value	Notes
Digital Core	2.5V +/- 5%	
Digital Core (GL Parts)	2.0V +/- 5%	In ReduceOn mode
I/O	3.3V +/- 5%	
Host Interface (HVDD)	3.3V +/- 5%	
Analog DAC (AVDD)	3.3V +/- 5%	
PLL (CVDD)	2.5V +/- 5%	
Flat Panel (FPVDD)	3.3V +/- 5%	

Note: 1. The low voltage parts (GL) is identical to the regular parts. The only difference is that the low voltage parts go through a more rigorous test flow to guarantee a low voltage operation.
2. The low voltage part can be a substitute for the regular part.

DC Specifications

Table 36: Digital DC Specification

Name	Parameter	Min	Typical	Max	Unit	Notes
V _{IL}	Input Low Voltage	-		0.8	V	
V _{IH}	Input High Voltage	2.0		-	V	
V _{OL}	Output Low Voltage	-		0.4	V	
V _{OH}	Output High Voltage	2.4		VDD+0.5	V	

Table 36: Digital DC Specification

Name	Parameter	Min	Typical	Max	Unit	Notes
I _{OZL}	Output Tri-state Current	-		10	μA	
I _{OZH}	Output Tri-state Current	-		10	μA	
I _{OZL} (Pull up pins)	Output Tri-state Current	-130		-10	μA	
I _{OZH} (Pull up pins)	Output Tri-state Current	-		10	μA	
I _{OZL} (Pull down pins)	Output Tri-state Current	-		10	μA	
I _{OZH} (Pull down pins)	Output Tri-state Current	10		130	μA	
C _{IN}	Input Capacitance			10	pF	
C _{OUT}	Output Capacitance			50	pF	
I _{CC*}	Power Supply Current		6		mA	

Note: * Suspend and standby current

Table 37: RAMDAC Characteristics

Parameter	Min	Typical	Max	Unit
Resolution Each DAC	-	8		Bits
LSB Size	-	54.7		μA
Output Full Scale Current	-	14.0		mA
Integral Linearity Error	0	-	1	LSB
Differential Linearity Error	0	-	1	LSB
DAC to DAC Mismatch	0	-	5%	
Power Supply Rejection Ratio	0	-	0.5	% /% AVDD
Output Compliance	0	-	1.2	V
Output Capacitance	-	-	10	pF
Glitch Energy	-	30	-	pV-Sec

Table 38: RAMDAC/Clock Synthesizer DC Specifications

Symbol	Parameter	Min	Typical	Max	Unit
AVDD	DAC Supply Voltage	3.17	3.3	3.47	V
CVDD	PLL Supply Voltage	2.38	2.50	2.63	V
VREF	Internal DAC voltage reference	1.1	1.235	1.35	V

AC Specifications**Table 39: RAMDAC AC Specifications**

Parameter	Typical	Max	Unit	Notes
DAC Output Delay	3		ns	1
DAC Output Rise/Fall Time	3		ns	2
DAC Output Setting Time	15		ns	
DAC-to-DAC Output Skew	2	15	ns	3

Note:

1. Measured from the 50% of VCLK to the 50% point of full scale transaction
2. Measured from 10% to 90% full scale
3. With DAC outputs equally loaded

Parameter	I _{OUT} (mA)	V _{OUT} (V)	BLANK	Input Data
White	14.0	0.7	1	FFh
Data	Data	Data	1	Data
Black	0	0	1	00h
~BLANK	0	0	0	Don't Care

Note: Condition for V_{OUT} is a 50 Ohm terminated load, use of the internal VREF and RFSC = 1.2 K Ohms.

AC Timing Specifications**Power On Reset****Table 40: Power-on Reset and Configuration Reset Timing**

Symbol	Parameter	Min	Max	Unit
t1	Reset active from VCC stable	5	-	ms
t2	Reset active from external oscillator stable	0	-	
t3	Reset active from ~PWRDN signal stable	2	-	ms
t4	Internal Power On ~RESET from VCC stable	-	200	ns
t5	External ~RESET to internal Power On ~RESET inactive	-	20	ms
t6	External ~RESET Pulse Width		-	ns
t7	Configuration cycle setup time	20	-	ns
t8	Configuration cycle hold time	5		

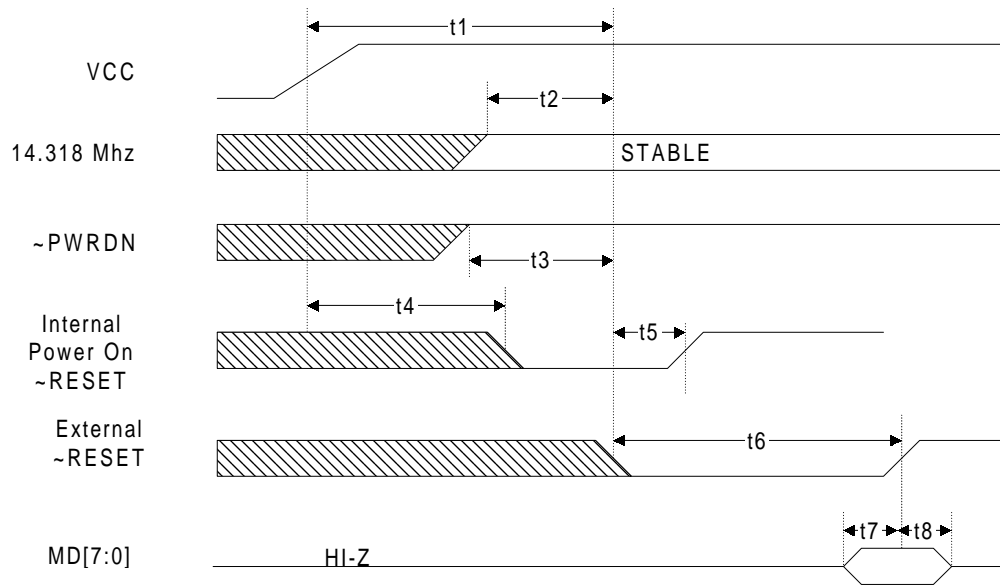

Figure 48: Power-on Reset and Reset Configuration Timing

PCI Bus Cycles

Table 41: PCI Bus Timing (33 MHz)

Symbol	Parameter	Min	Max	Unit
t1	~FRAME setup to CLK	7	-	ns
t2	AD[31:0] (address) setup to CLK	7	-	ns
t3	AD[31:0] (address) hold from CLK	0	-	ns
t4	AD[31:0] (Read Data) valid from CLK	2	11	ns
t5	AD[31:0] (Read Data) hold from CLK	0	-	ns
t6	AD[31:0] (Write Data) setup to CLK	7	-	ns
t7	AD[31:0] (Write Data) hold from CLK	0	-	ns
t8	C/~BE[3:0] (Command) setup to CLK	7	-	ns
t9	C/~BE[3:0] (Command) hold from CLK	0	-	ns
t10	C/~BE[3:0] (Byte Enable) hold from CLK	0	-	ns
t11	~TRDY High-Z to High from CLK	2	-	ns
t12	~TRDY active from CLK	2	11	ns
t13	~TRDY inactive from CLK	2	11	ns
t14	~TRDY High before High-Z	1T	-	CLK
t15	~IRDY setup to CLK	7	-	ns
t16	~IRDY hold from CLK	0	-	ns
t17	~DEVSEL active from CLK	2	11	ns
t18	~DEVSEL inactive from CLK	2	11	ns
t19	~DEVSEL High before High-Z	1T	-	CLK

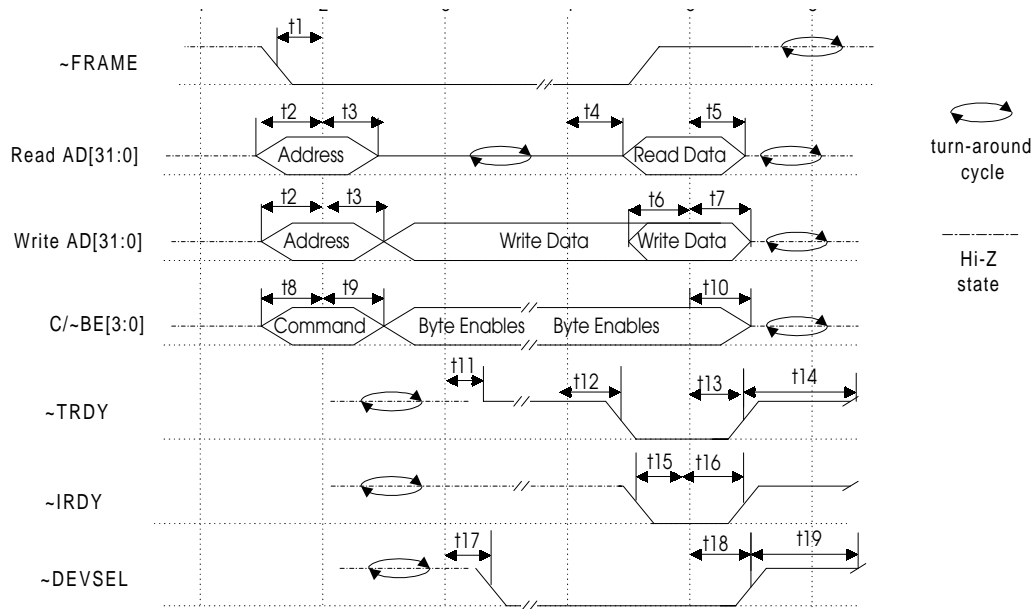

Figure 49: PCI Bus Timing Diagram

AGP BUS Cycles**Table 42: AGP 1X mode BUS Timing**

Symbol	PARAMETER	Min Spec	Max Spec	units
t cyc	CLK Cycle Time	15.0	30.0	ns
t valc	CLK to control signal (Output) valid delay	1.0	5.5	ns
t vald	CLK to data (Output) valid delay	1.0	6.0	ns
t on	Float to Active (Output) Delay	1.0	6.0	ns
t off	Active to Float (Output) Delay	1.0	14.0	ns
t suc	Control signals (Input) setup time to CLK	6.0	-	ns
t sud	Data (Input) setup time to CLK	5.5	-	ns
t h	Control signals (Input) hold time to CLK	0.0	-	ns

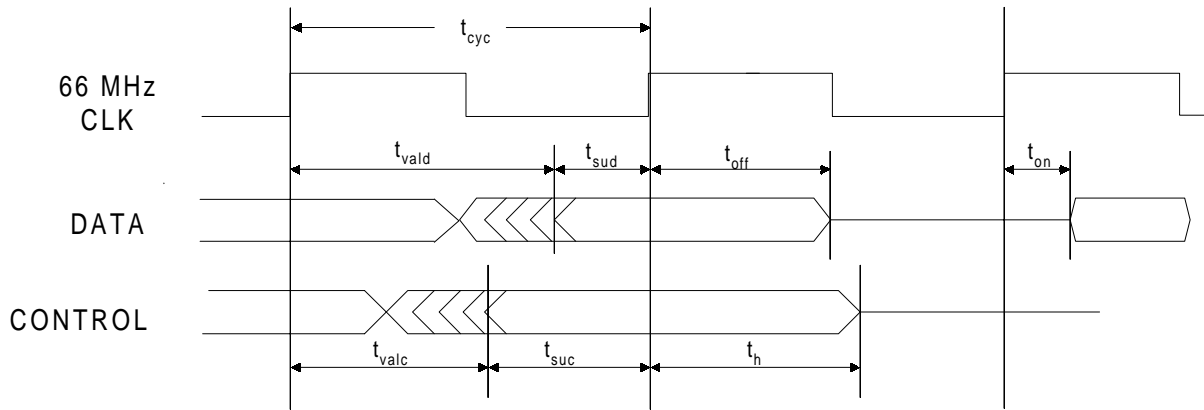

Figure 50: AGP Bus Timing Diagram

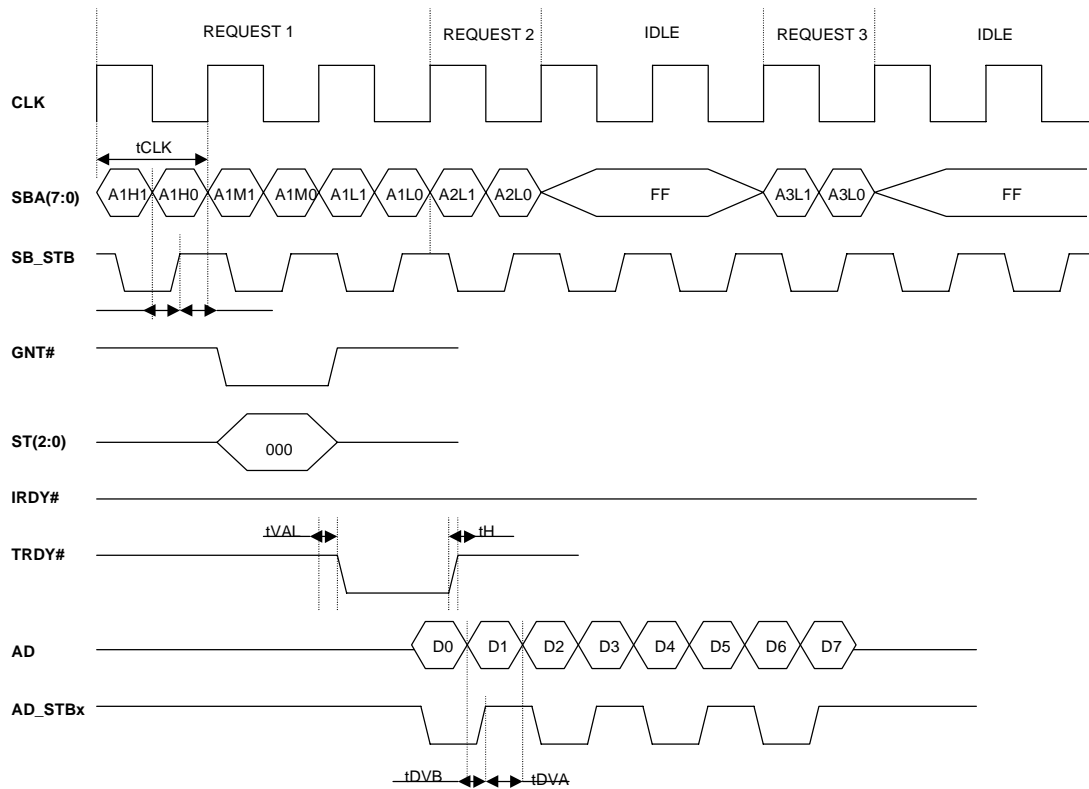

Figure 51: AGP 2X Read Request with Return Data (4Qw)

Table 43: AGP 2X Timing Parameters

Symbol	Description	Min.(ns)	Max.(ns)
tCLK	Clock	-	15
TDVB	Data valid before	1.7	
tDVA	Data valid after	1.7	
TVAL	CLK to control signal and Data valid delay	1	5.5
tH	Control signals hold time to CLK	0	-

Synchronous DRAM (SDRAM) and SGRAM Cycles**Table 44: SDRAM/SGRAM Memory Read Timing**

Symbol	Parameter	Min	Max	Unit
t1	SDCK Cycle Time	12		ns
t2	SDCK High Time	4		ns
t3	SDCK Low Time	4		ns
t4	SDCKEN hold time	3.5		ns
t5	SDCKEN setup time	3.5		ns
t6	Command (\bar{CS} , \bar{RAS} , \bar{CAS} , \bar{WE} , DSF, DQM) setup time	3.5		ns
t7	Command (\bar{CS} , \bar{RAS} , \bar{CAS} , \bar{WE} , DSF, DQM) hold time	3.5		ns
t8	Address/BA setup time	3.5		ns
t9	Address/BA hold time	2.5		ns
t10	Access time from SDCK		T-2	ns
t11	Data Out hold time from SDCK	4		ns
t12	Data In setup time from SDCK	3.5		ns
t13	Data In hold time from SDCK	3.5		ns
t14	Active to READ, WRITE delay	3T		
t15	Read Latency	3T		
t16	Write recovery time	2T		

Note: T = SDCK clock period

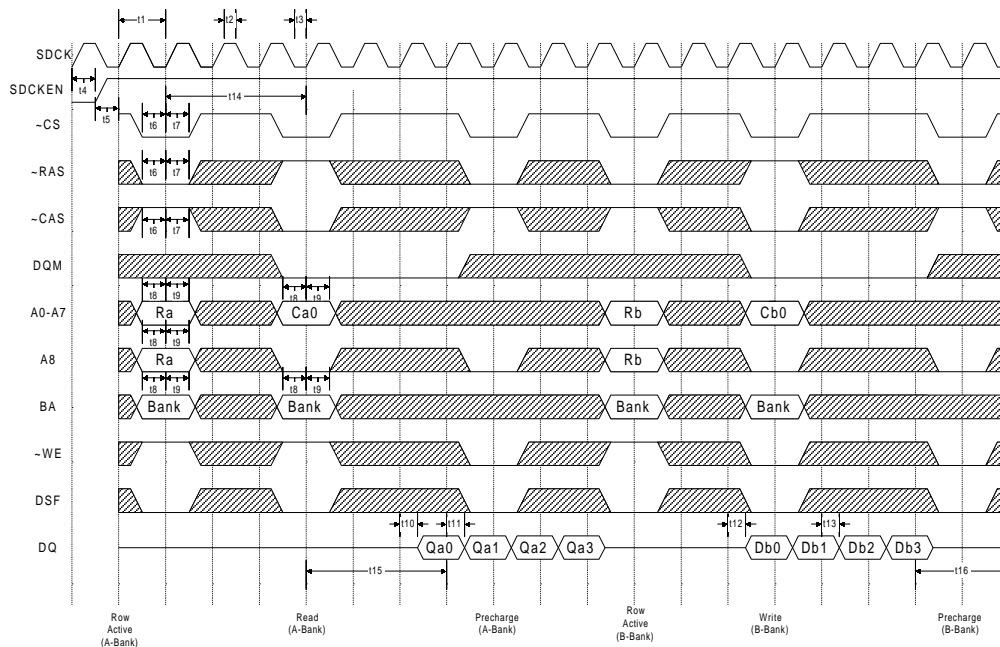

Figure 52: SDRAM/SGRAM Read and Write Cycles

Flat Panel Interface Cycle Timing

Table 45: Color TFT Interface Timing

Symbol	Parameter	Min	Max	Unit
t1	TFT FPSCLK Cycle Time	12		ns
t2f	FDATA setup to FPSCLK falling edge	0.5T-2		ns
t3f	FDATA hold from FPSCLK falling edge	0.5T-2		ns
t4f	DE setup to FPSCLK falling edge	0.5T-4		ns
t5f	DE hold from FPSCLK falling edge	0.5T-4		ns
t2r	FDATA setup to FPSCLK rising edge	0.5T-2		ns
t3r	FDATA hold from FPSCLK rising edge	0.5T-2		ns
t4r	DE VSYNC setup to FPSCLK rising edge	0.5T-4		ns
t5r	DE VSYNC hold from FPSCLK rising edge	0.5T-4		ns
t6	FHSYNC Pulse Width	8	16	T
t7	FVSYNC Pulse Width	1		FHSYNC

Note: T = pixel clock rate on LCD

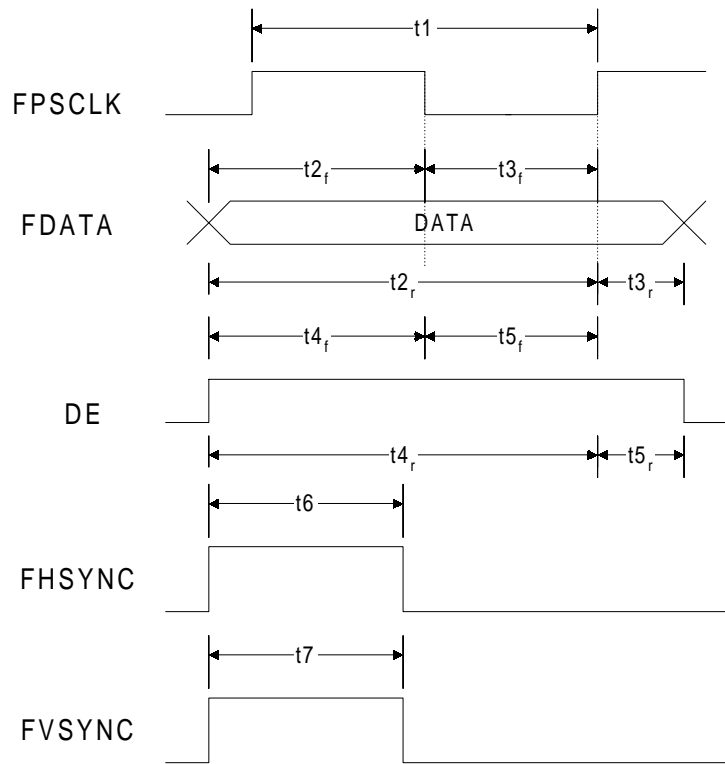

Figure 53: TFT Interface Timing

Table 46: Color DSTN Interface Timing

Symbol	Parameter	16-Bit		24-Bit		Unit
		Min	Max	Min	Max	
t1	DSTN FPSClk High Time	2.5T-3	3T+3			ns
t2	DSTN FPSClk Low Time	2.5T-3	3t+3			ns
t3	FDATA setup to FPSClk falling edge	2.5T-5				ns
t4	FDATA hold from FPSClk falling edge	2.5T-5				ns
t5	LP Pulse Width	16T	32T			ns
t6	FP setup to LP falling edge	20T				ns
t7	FP hold from LP falling edge	4T				ns
t8	DSTN FPSClk active from LP falling edge	16T				ns
t9	DSTN FPSClk inactive to LP rising edge	8T				ns

Note: T = pixel clock rate on LCD

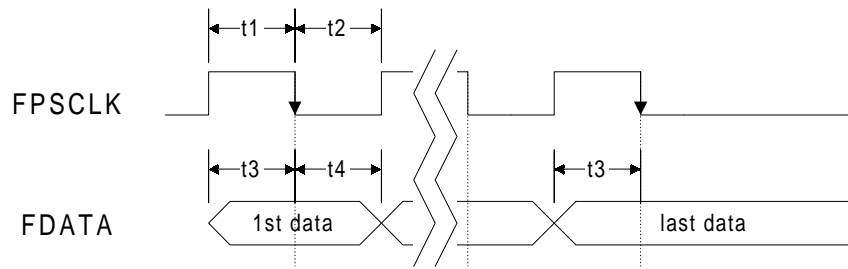

Figure 54: DSTN Interface (Clock and Data) Timing

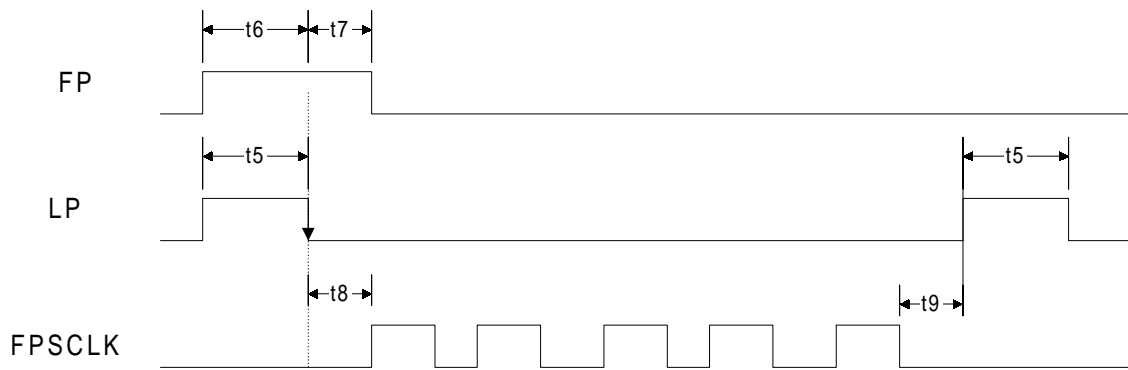

Figure 55: DSTN Interface (Control and Clock) Timing

Thermal Characteristics

Maximum ambient temperature versus air flow

The thermal operating characteristics of the chip depend on the board it is mounted on and on the air flow. Typical maximum ambient temperatures (T_{Amax}) can be derived from the equation:

$$T_{Amax} = T_{Jmax} - P * \theta_{JA}$$

where T_{Jmax} = max junction temperature
 P is power dissipation
 and θ_{JA} is junction-to-ambient thermal resistance.

Power dissipation varies with different display modes, but is typically between 1.0W to 1.8W when the chip is operating at nominal VDD.

The table below shows typical values of θ_{JA} and T_{Amax} for different airflows over the SM721G4/G8 packages.

Table 47: Maximum ambient temperatures vs air flow

Air flow (ms)	SM721G4/G8	
	θ_{JA} (C/W)	T_{Amax} degree C
0	24.2	46
1	20.0	54
2	18.3	57

Maximum recommended junction and case temperatures

The maximum junction temperature allowed (for worst case conditions) is 100° C, and the maximum recommended operating temperature is calculated for junction temperature of about 90° C .

Chapter 28: Mechanical Dimensions

Symbol	dimension in mm			dimension in inch		
	MIN	NOM	MAX	MIN	NOM	MAX
A	2.20	2.33	2.50	0.087	0.092	0.098
A1	—	0.60	—	—	0.024	—
A2	1.12	1.17	1.22	0.044	0.046	0.048
b	—	0.75	—	—	0.030	—
c	0.51	0.56	0.61	0.020	0.022	0.024
D	26.80	27.00	27.20	1.055	1.063	1.071
D1	—	24.13	—	—	0.950	—
D2	23.80	24.00	24.20	0.937	0.945	0.953
D3	17.95	18.00	18.05	0.707	0.709	0.711
E	26.80	27.00	27.20	1.055	1.063	1.071
E1	—	24.13	—	—	0.950	—
E2	23.80	24.00	24.20	0.937	0.945	0.953
E3	17.95	18.00	18.05	0.707	0.709	0.711
e	—	1.27	—	—	0.050	—
ddd	—	—	0.15	—	—	0.006
θ	—	30° TYP	—	—	30° TYP	—

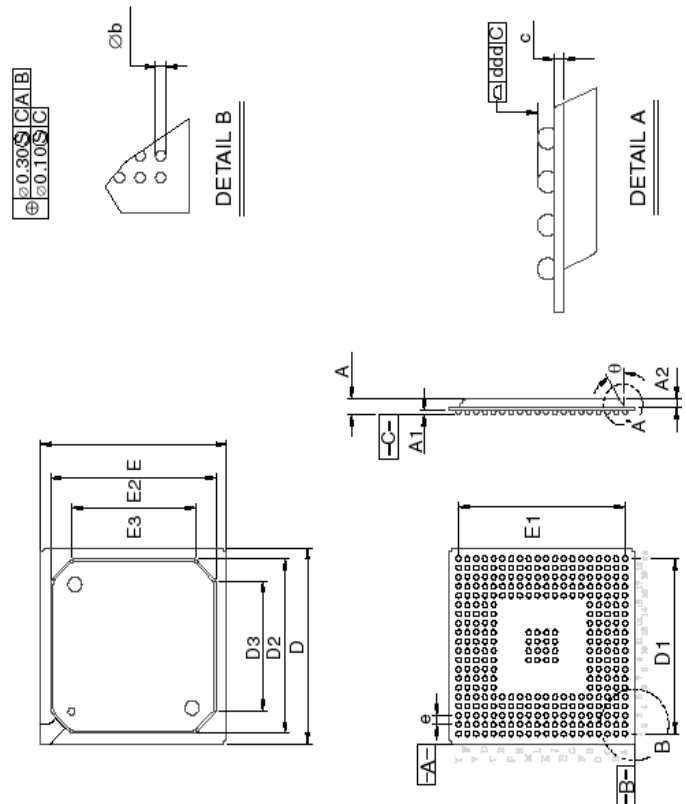

Figure 56: 316 BGA Mechanical Dimensions

Table 46: Ordering Information

Order Number	Description	Detailed Information
M721GM040000-BB	SM721G4 BB	Lynx3DM4 316 BGA Macrovision 4M Rev. BB
SM721GM04LF00-BB	SM721GF4 BB	Lynx3DM4 316 BGA Macrovision 4M Rev. BB (lead free)
SM721GM080000-BB	SM721G8 BB	Lynx3DM8 316 BGA Macrovision 8M Rev. BB
SM721GM08LF00-BB	SM721GF8 BB	Lynx3DM8 316 BGA Macrovision 8M Rev. BB (lead free)
SM721GL040000-BB	SM721GL4 BB	Lynx3DM4 316 BGA Macrovision 4M Rev. BB (low power)
SM721GL04LF00-BB	SM721GLF4 BB	Lynx3DM4 316 BGA Macrovision 4M Rev. BB (low power/lead free)
SM721GL080000-BB	SM721GL8 BB	Lynx3DM8 316 BGA Macrovision 8M Rev. BB (low power)
SM721GL08LF00-BB	SM721GLF8 BB	Lynx3DM8 316 BGA Macrovision 8M Rev. BB (low power/lead free)

Chapter 29: Index

Numerics

3D Engine 1-5
4Fsc 1-6, 17-1

A

AGC 17-4
AGP 1-4, 27-5
Alpha Blending 1-5, 16-4
Anti Alias 16-4

B

Bilinear 16-3
Bi-Linear Filtering 1-5
Block Write 1-4
Blue 2-4
Bus Master 1-4

C

Capture 22-45
CCIR 601 1-6, 17-1
Clock Synthesizer 27-2
Closed Captioning 1-6, 17-1, 17-4
Color Keys 22-23
Composite Video 1-6, 17-1
CRTC 20-9

D

Device ID 4-1, 19-2
Direct3D 16-1
Dithering Engine 21-20
DPMS 21-45
Drawing Engine 21-7, 22-4
DSTN 1-7, 2-4, 27-9
Dynamic Power Management 1-6

E

EMI 21-32

F

Flat Panel 2-4
Flicker Filter 1-7
Fog 1-5, 16-4

G

Gouraud Shading 1-5
Green 2-4

H

Hardware Cursor 21-51, 21-56
HIF 1-4
Horizontal Blank 20-10
Horizontal Sync 20-11, 21-30
Host Interface Unit 1-4

I

IDCT 24-1
IEEE 754 Floating Point Setup Engine 16-1
IEEE Floating Point Setup Engine 1-5
Interlace 21-58

M

Macrovision 1-6, 17-1, 17-3
Mask 22-16
MCLK 1-8, 21-45
Memory 20-8
Memory Clock 2-3
MIP Mapping with LOD 1-5
Mirroring 1-5
Motion Comp 23-2
Motion Compensation 1-5, 15-1
MPEG-2 1-5, 15-1

N

NTSC 1-6, 17-1, 17-4

O

OpenGL 16-1
Overview 1-4

P

PAL 1-6, 17-1, 17-4
Parity 2-2
PCI 1-4, 19-2, 27-4
Perspective Correct 16-3
Perspective Correction 1-5
PLL 1-8
Pop-up Icon 21-52
Power Down 2-2, 19-7, 21-13
Pull-up/ Pull-Down 2-2

R

RAMDAC 1-8, 20-31, 27-2
Read FIFO2 21-27
Red 2-4
Refresh Clock 2-3, 21-45
Rendering Engine 1-5
Reset 20-6, 27-3

S

SDRAM/SGRAM 27-7
Sequencer 20-6
Setup Engine 1-5
SGRAM 2-3
Signature Analyzer 22-37
SM821 Pin Diagram 2-6
Specular Highlights 1-5
Square Pixel 1-6, 17-1
Stretch 22-14
Sub Picture 22-37
Sub-carrier 17-5
Sub-Picture 22-32
Subsystem ID 19-5
Subsystem Vendor ID 19-5
S-video 1-6, 17-1

T

Test Mode 2-5
Texture 16-3
Texture Compositing 16-3
TFT 1-7, 2-4, 27-8
Transparency 16-4
Triangle Engine 16-2
Triangle Setup 16-1
Tri-linear Filtering 1-5
Trilinear Mip-mapping 16-3

TV 1-7, 21-58
TV Encoder 1-6, 17-1, 21-41

U

Underscan 1-7
User 21-49

V

VCLK 1-8, 21-46
Vendor 4-1
Vendor ID 4-1, 19-2
Vertical Blank 20-18
Vertical Sync 20-12, 20-16, 21-32
VGA 1-8
Video Capture 1-7
Video Port 2-4
Video Processor 1-7, 21-7
Video Window I 22-26
Virtual Refresh 14-2, 21-19

W

Write FIFO 21-27

Y

YUV to RGB 22-36

Z

Z Engine 16-2
Zoom Video Port 1-7
ZV Port 8-1

Appendix A: Video Modes

This appendix lists the various tables of video modes supported under various configurations of Lynx3DM: CRT only, LCD only, or simultaneous. The parameters listed in the following tables define the standard capabilities of the Lynx3DM when it is used with the Silicon Motion's Video BIOS.

Abbreviations used:

Txt: text mode

Gr: graphics mode

Standard IBM Compatible VGA Modes

The table details the standard VGA modes supported in CRT only.

Table 47: Standard IBM Compatible VGA Modes

Mode # (Hex)	Type	Colors	Alpha	Resolution	Font	Clock MHz	Hsync KHz	Vsync Hz	Memory Min	Buffer Start
0,1	Txt	16	40x25	320x200	8x8	25.175	31.55	70.3	256K	B8000
0,1*	Txt	16	40x25	320x350	8x14	25.175	31.55	70.3	256K	B8000
0,1+	Txt	16	40x25	360x400	9x16	28.322	31.34	69.8	256K	B8000
2,3	Txt	16	80x25	640x200	8x8	25.175	31.55	70.3	256K	B8000
2,3*	Txt	16	80x25	640x350	8x14	25.175	31.55	70.3	256K	B8000
2,3+	Txt	16	80x25	720x400	9x16	28.322	31.34	69.8	256K	B8000
4,5	Gr	4	40x25	320x200	8x8	25.175	31.55	70.3	256K	B8000
6	Gr	2	80x25	640x200	8x8	25.175	31.55	70.3	256K	B8000
7	Txt	Mono	80x25	720x350	9x14	28.322	31.34	69.8	256K	B8000
7+	Txt	Mono	80x25	720x400	9x16	28.322	31.34	69.8	256K	B8000
D	Gr	16	40x25	320x200	8x8	25.175	31.55	70.3	256K	A0000
E	Gr	16	80x25	640x200	8x8	25.175	31.55	70.3	256K	A0000
F	Gr	Mono	80x25	640x350	8x14	25.175	31.55	70.3	256K	A0000
10	Gr	16	80x25	640x350	8x14	25.175	31.55	70.3	256K	A0000
11	Gr	2	80x30	640x480	8x16	25.175	31.55	60.1	256K	A0000
12	Gr	16	80x30	640x480	8x16	25.175	31.55	60.1	256K	A0000
13	Gr	256	40x25	320x200	8x8	25.175	31.55	70.3	256K	A0000

NOTE: For Modes 3 and 7, 8-dot Fonts are used on the LCD.

VESA Super VGA Modes

VESA extended video modes are supported by the LYNX family BIOS (subject to the constraints of the video subsystem hardware) as follows:

Table 48: VESA Super VGA Modes

VESA Mode # (Hex)	Extended Mode	Type	Colors	Alpha	Resolution	Font	Memory Min	Buffer Start
(Min.)	Buffer Start							
101	50	Gr	256	80x30	640x480	8x16	512K	A0000
102	6A	Gr	16	100x75	800x600	8x8	256K	A0000
103	55	Gr	256	100x75	800x600	8x8	512K	A0000
104	6B	Gr	16	128x48	1024x768	8x16	512K	A0000
105	60	Gr	256	128x48	1024x768	8x16	1M	A0000
107	65	Gr	256	160x64	1280x1024	8x16	2M	A0000
111	52	Gr	64K	80x30	640x480	8x16	1M	A0000
112	53	Gr	16M	80x30	640x480	8x16	1M	A0000
114	57	Gr	64K	100x75	800x600	8x8	1M	A0000
115	58	Gr	16M	100x75	800x600	8x8	2M	A0000
117	62	Gr	64K	128x100	1024x768	8x8	2M	A0000
118	63	Gr	16M	128x100	1024x768	8x8	4M	A0000
11A	67	Gr	64K	160x128	1280x1024	8x8	4M	A0000
11B	68	Gr	16M	160x128	1280x1024	8x8	4M	A0000

Low Resolution Modes

The LYNX family BIOS supports low-resolution modes from 320x200 to 640x400 in 8/16-bit colors for DirectDraw. The low resolution modes are defined as follows:

Table 49: Low Resolution Modes

Mode # (Hex)	Type	Colors	Resolutions	Vsync (Hz)	Video Memory	Buffer Start
40	Gr	256	320x200	70	1MB	A0000
41	Gr	64K	320x200	70	1MB	A0000
42	Gr	256	320x240	75, 60	1MB	A0000
43	Gr	64K	320x240	75, 60	1MB	A0000
44	Gr	256	400x300	75, 60	1MB	A0000
45	Gr	64K	400x300	75, 60	1MB	A0000
46	Gr	256	512x384	75	1MB	A0000
47	Gr	64K	512x384	75	1MB	A0000
48	Gr	256	640x400	70	1MB	A0000
49	Gr	64K	640x400	70	1MB	A0000

NOTE: For modes 320x240 and 400x300, default refresh rate is set to 60Hz and optimal is set to 75Hz.

640 by 480 Resolution Modes**Table 50: 640 x 480 Extended Modes**

Mode # (Hex)	VESA Mode # (Hex)	Type	Colors	Alpha Format	Font	VCLK (MHz)	Hsync +/- (KHz)	Vsync +/- (Hz)	Video Memory	Buffer Start
50	101	Gr	256	80x30	8x16	25.175	31.5	60.0	512 KB	A0000
						31.5	37.5-	75.0-		
						36	43.3	85.0		
52	111	Gr	64K	80x30	8x16	25.0	31.5	60.0	1MB	A0000
						31.5	37.5-	75.0-		
						36	43.3	85.0		
53	112	Gr	16M (24-bit)	80x30	8x16	25.0	31.5	60.0	1MB	A0000
						31.5	37.5-	75.0-		
						36	43.3	85.0		
54		Gr	16M (32-bit)	80x30	8x16	25.0	31.5	60.0	2MB	A0000
						31.5	37.5-	75.0-		
						36	43.3	85.0		

NOTE: For the above resolutions, the default refresh rate for LCD and Simul mode is 60Hz.

800 by 600 Resolution Modes**Table 51: 800x600 Extended Modes**

Mode # (Hex)	Vesa Mode# (Hex)	Type	Colors	Alpha Format	Font	VCLK (MHz)	Hsync +/- (KHz)	Vsync +/- (Hz)	Video Memory	Buffer Start
6A	6A	Gr	16	100x75	8x8	40.0	37.9+	60.3+	256KB	A0000
55	103	Gr	256	100x75	8x8	40.0	37.9+	60.3+	512KB	A0000
						49.5	46.9+	75.0+		
						56.25	53.7	85.0		
57	114	Gr	64K	100X75	8X8	40.0	37.9+	60.3+	1MB	A0000
						49.5	46.9+	75.0+		
						56.25	53.7	85.0		
58	115	Gr	16M (24-bit)	100X75	8X8	40.0	37.9+	60.3+	2MB	A0000
						49.5	46.9+	75.0+		
						56.25	53.7	85.0		
59		Gr	16M (32-bit)	100X75	8X8	40.0	37.9+	60.3+	2MB	A0000
						49.5	46.9+	75.0+		
						56.25	53.7	85.0		

NOTE: For the above resolutions, the default refresh rate for LCD and Simul mode is 60Hz.

1024 by 768 Resolution Modes**Table 52: 1024x768 Extended Modes**

Mode # (Hex)	VESA Mode# (Hex)	Type	Colors	Alpha Format	Font	VCLK (MHz)	Hsync +/- (KHz)	Vsync +/- (Hz)	Video Memory	Buffer Start
6B	104	Gr	16	128x48	8x16	65.0	48.4 -	60.0 -	512KB	A0000
60	105	Gr	256	128x48	8x16	65.0	48.4 -	60.0 -	1MB	A0000
						78.8	60.0+	75.0+		
						94.5	68.7	85.0		
62	117	Gr	64K	128x48	8x16	65.0	48.4 -	60.0 -	2MB	A0000
						78.8	60.0+	75.0+		
						94.5	68.7	85.0		
63	118	Gr	16M	128x48	8x16	65.0	48.4 -	60.0 -	4MB	A0000
			(24-bit)			78.8	60.0+	75.0+		
			94.5			68.7	85.0			
64		Gr	16M	128x48	8x16	65.0	48.4 -	60.0 -	4MB	A0000
			(32-bit)			78.8	60.0+	75.0+		
			94.5			68.7	85.0			

NOTE: For the above resolutions, the default refresh rate for LCD and Simul mode is 60Hz

1280 by 1024 Resolution Modes**Table 53: 1280x1024 Extended Modes**

Mode # (Hex)	VESA Mode# (Hex)	Type	Colors	Alpha Format	Font	VCLK (MHz)	Hsync +/- (KHz)	Vsync +/- (Hz)	Video Memory	Buffer Start
65	107	Gr	256	160x64	8x16	78.8	46.4	86.8i+	2 MB	A0000
						108	64	60.0		
						135	79.98	75.0		
67	11A	Gr	64K	160x64	8x16	78.8	46.4	86.8i+	4 MB	A0000
						108	64	60.0		
						135	79.98	75.0		
68		Gr	16M	160x64	8x16	78.8	46.4	86.8i+	4 MB	A0000
			(24-bit)			108	64	60.0		
			135			79.98	75.0			

NOTE: For the above resolutions, the default refresh rate for LCD and Simul mode is 60Hz

Appendix B: Popup Icon Consideration

Introduction

The Lynx family of silicon supports both the hardware cursor and popup icon. System BIOS uses the popup icon to display system information, such as: Battery Status, LCD Brightness and more. The display driver for GUI operating system uses the hardware Cursor to increase performance. Since both popup icon and hardware cursor image locations are closely coupled both will be described. This appendix details popup icon support and how to implement the support in system BIOS.

Popup Icon

The popup icon size is 64x64, and can be zoomed up by 2 to become 128x128 popup icon. The popup icon can be programmed to anywhere on the screen display.

Furthermore, the popup icon is supported only through the CRT backend. Thus, when display image is processed through the LCD backend (as in the case of Virtual Refresh mode), there is no popup icon support on the LCD.

For example, in simultaneous mode since a display image is processed through the CRT backend, the popup icon can be displayed on both LCD and CRT. Similarly, in LCD only mode (Standard Refresh mode), popup icon can be displayed on the LCD. However, in Dual Monitor mode (or Virtual Refresh mode) under Windows 98, the popup icon will only be displayed on CRT and not on the LCD.

Icon Pattern Memory Location

The Icon pattern memory location is specified in PHR80 and PHR81 registers. These two registers allocate 2KB off-screen video memory within the maximum physical memory. Silicon Motion assigns the highest 2KB address for the physical memory installed. The lower 1KB is used to store Pop-Up icon image. The upper 1KB is used to store hardware cursor image. (Please also refer to Figure 57)

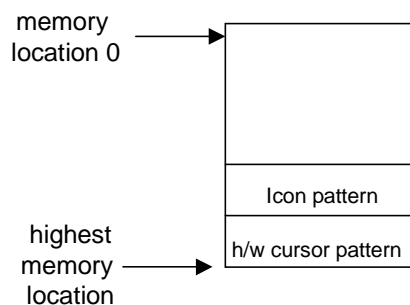

Figure 57: Hardware Cursor and Popup Icon Memory Location

Icon Pattern

Each pixel of the Icon pattern uses 2-bit to select the different color formats. The table below lists the various color selects: transparent, Icon Color1 is defined in POP84 register, Icon Color2 is defined in POP85 register, and Icon Color3 is defined in POP86 register.

Icon Pattern [1:0]	Color Source
00	transparent
01	Icon Color1
10	Icon Color 2
11	Icon Color 3

Furthermore, pixel data is stored in sequential order. For example, Bit[7:6] of a byte in the video memory is the first pixel of the Icon pattern. Bit[5:4] is the second pixel of the Icon pattern.

Bit 7:6	Bit 5:4	Bit 3:2	Bit 1:0
1st pixel	2nd pixel	3rd pixel	4th pixel

Each of the popup icon color registers (POP83-85) is defined in the same way described below:

The 8-bit color register is defined to be 3:3:2 for R:G:B respectively as shown on the table below:

7	6	5	4	3	2	1	0
Red			Green			Blue	
2	1	0	2	1	0	1	0

The Lynx family of silicon will take the 8-bit Icon color and convert it into 24-bit Icon color internally. For example, R2R1R0G2G1G0B1B0 will be expanded to R2R1R0R0R0R0R0G2G1G0G0G0G0G0G0B1B0B0B0B0B0B0.

Icon Control

Register POP82 controls the popup icon enable and size.

POP82[7] controls Popup Icon Enable

0 = Disable

1 = Enable

POP82[6] controls Popup Icon Size

0 = 64x64

1 = 128x128

Video BIOS Function Call

Video BIOS has call services for popup icon. The table below lists the available video BIOS function calls. For more detail information, please refer to the Lynx family BIOS specification.

Function Definition	AX	BX	CH	CL	DX	ES:SI
Icon Control	5F10	0		0 = disable		
1 = enable						
Icon Size	5F10	1		0 = 64x64		
1 = 128x128						
Icon Location	5F10	2	X start	X start	Y start	
Icon Color1	5F10	3	1	Color Value		
Icon Color2	5F10	3	2	Color Value		
Icon Color3	5F10	3	3	Color Value		
Load Icon Pattern	5F10	5				Pattern Address

Furthermore, there is a sample code (pop8.exe) which shows how to use the video BIOS function call to set up popup icon image. Please request this sample code from your local technical support staff.

Appendix C: SMI Handler Programming Consideration

Introduction

The Lynx family of silicon is designed for notebook systems. Notebook systems require support of SMM (system management mode) for handling system-wide functions, such as: power management, system hardware control, and proprietary OEM-design code. This application note describes consideration for system BIOS when implementing SMI (System management interrupt) handler for the Lynx family of silicon.

Background

SMM is a special-purpose operating mode provided for handling system-wide functions. The main benefit of SMM is that it offers an easily isolated processor environment that operates transparently to the operating system or software applications.

When SMM is invoked through SMI, the processor saves the current state of the processor, then switches to a separate operating environment contained in the system management RAM. While in SMM, the processor executes a SMI handler code to perform operations such as power down HD when it is idle or displaying an OEM-design message on the screen. When the SMI handler has completed its operations, it executes a resume instruction. This instruction causes the processor to reload the saved context of the processor, switch back to protected or real mode, and resume executing the interrupted operating-system program or interrupted application programs.

System BIOS Consideration

The video BIOS provides an alternate INT 10h entry to allow SMI handlers to execute VGA BIOS function calls. This entry point bypasses the STI (Set Interrupt Flag) instruction at the beginning of the standard interrupt handler.

Int10 Vector Entry

The standard interrupt handler INT10 vector is located in 0000:0040h. This INT10 handler will issue STI instruction.

Alternate INT10 Entry

The alternate INT10 entry is specified within the content of location C000:0034h. This alternate INT10 handler entry does not issue STI.

Note: For system BIOS from Phoenix, there is a function named: PmModifyInt10Vector that can be used to modify the INT10 vector.

Video BIOS service calls read/modify the I/O and memory-mapped registers. The memory-mapped registers are accessed through A000-B000 range in real mode or SMM; they are video processor registers, drawing engine registers and capture port registers. Due to the fact that A000-B000 range is reserved for power management under SMM mode, special consideration is necessary:

There are two methods as listed below:

1. **Exit SMM**

Exit SMM when calling video BIOS services or accessing memory-mapped registers. Upon completion, it is ok to resume back to SMM.

2. **Map Power Management Data to another location**

The default area for storing the power management data is A000-B000. In order to allow video BIOS services to access A000-B000 area, system BIOS can map the A000-B000 data to another location, such as D000-E000.

Appendix D: Programming USR [3:0] Pins

Application Notes for control of USR [3:0] Pins

*GPR 72 is General Purpose Register 72 with address 3C5h and index 72h
GPR 73 is General Purpose Register 73 with address 3C5h and index 73h

USR0

GPR72 [4]	GPR72 [0]	USR0 Pad	Remark
0	0	Input	*
0	1	Input	
1	0	Output 0	
1	1	Input	

* When USR0 is in input state, the input status can be read from GRP72[2].

USR1

GPR72 [5]	GPR72 [1]	USR1 Pad	Remark
0	0	Input	*
0	1	Input	
1	0	Output 0	
1	1	Input	

* When USR1 is in input state, the input status can be read from GRP72[3].

USR2

GPR73 [5]	GPR73 [1]	USR1 Pad	Remark
0	0	Input	*
0	1	Input	
1	0	Output 0	
1	1	Input	

* When USR2 is in input state, the input status can be read from GRP73[2]. When toggling USR2 as an input pin, it will generate a hardware interrupt. The status of the interrupt can be read at bit 2 of SCR1C register.

USR3

GPR73 [5]	GPR73 [1]	USR1 Pad	Remark
0	0	Input	*
0	1	Input	
1	0	Output 0	
1	1	Input	

* When USR3 is in input state, the input status can be read from GRP73[3]. When toggling USR3 as an input pin, it will generate a hardware interrupt. The status of the interrupt can be read at bit 3 of SCR1C register.

Appendix E: Monitor & TV Detect

CRT Monitor Detect

To simplify the monitor detect procedure SM720 implemented four new registers (*ccr7a*, *ccr7b*, *ccr7c*, *ccr7d*) and detect circuitry. As for R, G, B corresponds to *ccr7a*, *ccr7b*, *ccr7c* data and *ccr7d*[_7] as enable. When all these registers are programmed properly, and without waiting for sync period the users can read back the register *3c2*[_4] to determine if the monitor is connected.

3c2[_4] = 0; No monitor detect

3c2[_4] = 1; Color monitor detect

TV Detect

To simplify the TV monitor detect procedure SM720 also uses registers (*ccr7a*, *ccr7b*, *ccr7c*, *ccr7d*), and TV monitor detect circuitry.

For Y = {*ccr7a*,00} as 10 bit data

For C = {*ccr7b*,00} as 10 bit data

For CVBS = {*ccr7c*,00} as 10 bit data

With *ccr7d*[_7] as enable and all these registers are programmed properly the users can read back the register *ccr7d*[_6] to determine SVHS monitor's status.

Ccr7d[_6] = 0; No TV monitor detect

Ccr7d[_6] = 1; TV monitor detect

With *ccr7d*[_7] as enable and all these registers are programmed properly the users can read back the register *ccr7d*[_5] to determine CVBS monitor's status.

Ccr7d[_5] = 0; No TV monitor detect

Ccr7d[_5] = 1; TV monitor detect

Appendix F: CRT Timing Register Summary

CRT Timing Register Summary

Table 54: CRT Timing and LCD Shadow Register Summary

Parameter	CRT Register Bits						
	[10]	[9]	[8]	[7]	[6]	[5]	[4:0]
H Total				CRT00[7]	CRT00[6]	CRT00[5]	CRT00[4:0]
H Total Shadow				SVR40[7]	SVR40[6]	SVR40[5]	SVR40[4:0]
H Display End				CRT01[7]	CRT01[6]	CRT01[5]	CRT01[4:0]
H Blank Start				CRT02[7]	CRT02[6]	CRT02[5]	CRT02[4:0]
H Blank Start Shadow				SVR41[7]	SVR41[6]	SVR41[5]	SVR41[4:0]
H Blank End				CRT33[6]	CRT33[5]	CRT05[7]	CRT03[4:0]
H Blank End Shadow						SVR44[7]	SVR42[4:0]
H Sync Start				CRT04[7]	CRT04[6]	CRT04[5]	CRT04[4:0]
H Sync Start Shadow				SVR43[7]	SVR43[6]	SVR43[5]	SVR43[4:0]
H Sync End							CRT05[4:0]
H Sync End Shadow							SVR44[4:0]
V Total	CRT30[3]	CRT07[5]	CRT07[0]	CRT06[7]	CRT06[6]	CRT06[5]	CRT06[4:0]
V Total Shadow		SVR4A[5]	SVR4A[0]	SVR45[7]	SVR45[6]	SVR45[5]	SVR45[4:0]
V Sync Start	CRT30[0]	CRT07[7]	CRT07[2]	CRT10[7]	CRT10[6]	CRT10[5]	CRT010[4:0]
V Sync Start Shadow		SVR4A[7]	SVR4A[2]	SVR48[7]	SVR48[6]	SVR48[5]	SVR48[4:0]
V Sync End							CRT011[3:0]
V Sync End Shadow							SVR49[3:0]
V Display End	CRT30[2]	CRT07[6]	CRT07[1]	CRT12[7]	CRT12[6]	CRT12[5]	CRT012[4:0]
V Blank Start	CRT30[1]	CRT09[5]	CRT07[3]	CRT15[7]	CRT15[6]	CRT15[5]	CRT015[4:0]
V Blank Start Shadow		SVR4B[5]	SVR4A[3]	SVR46[7]	SVR46[6]	SVR46[5]	SVR46[4:0]
V Blank End		CRT33[4]	CRT33[3]	CRT16[7]	CRT16[6]	CRT16[5]	CRT016[4:0]
V Blank End Shadow				SVR47[7]	SVR47[6]	SVR47[5]	SVR47[4:0]
Line Compare				CRT18[7]	CRT18[6]	CRT18[5]	CRT018[4:0]
Offset				CRT13[7]	CRT13[6]	CRT13[5]	CRT013[4:0]

Note: Bits shown in bold text are SMI extended registers

Appendix G: 2D/3D Bus Master DMA Data Stream Format

2D3D Bus Master - DMA Data Stream Format

DMA data format is always in Mask-Data pair. It could be one 32-bit Mask followed by one 32-bit data, or more sets of 32-bit data depending on the setting in the mask.

DMA 32-bit Mask

Vertex Data DMA Mask Format

31	30	29	28	27	26	25	24	23	22	21	20	19	18	17	16
0	0	DMA CONTROL		VS		FVF FORMAT				RESERVED					
15	14	13	12	11	10	9	8	7	6	5	4	3	2	1	0
RESERVED						PC	DT	RESERVED		GCS		GCFC		ALL	XY

Bit 31:30 DMA Data Type
00: Vertex data
 01: 2D/3D registers/commands
 10: Host blit write data
 11: Low level engine (wait, flush, flip,...etc.)*

Bit 29:28 DMA Control
 x1: End of A DMA buffer
 1x: End of A DMA block
 Each DMA buffer could contain several DMA blocks. Each DMA block (max 4K byte) consists of a number of DMA mask/data pairs.

Hardware DMA operation sequence:

1. Fetch the first DMA mask;
2. Fetch the DMA data defined by the present DMA mask and fetch the next DMA mask;
3. Load/check the next DMA mask:
 - a) If end-of- DMA buffer then DMA is done; or
 - b) If end-of-block (go to step 1); or
 - c) Else (go to step 2)

Bit 27:26 DMA head - Vertex selection (VS)
 00 data for vertex 0
 01 data for vertex 1
 10 data for vertex 2
 11 data contains 3 vertices (v0, v1 and v2) for list or first triangle in the strip or fan

- Bit 25:22** DMA head - FVF Format - there are 5 groups
 xxxx include x, y, z
 lxxx include diffuse color
 x1xx include specular color
 xx1x include texture 1 (Wi1, U1, V1)
 xxxl include texture 2, (U2, V2)*
- Bit 21:10** Reserved
- Bit 9** Go command - Perspective correction off when = 1 (PC)
- Bit 8** Go command - Dual textures when = 1 (DT)
- Bit 7:6** Reserved
- Bit 5:4** Go command shading (GCS)
 00: Gouraud shading
 01: Flat shading
 1x: Reserved
- Bit 3:2** Go command flat color section (GCFC)
 00: Vertex 0's diffuse color as flat color
 01: Vertex 1's diffuse color as flat color
 10: Vertex 2's diffuse color as flat color
 11: Reserved
- Bit 1** All_go
- Bit 0** XY_go

* Not supported for SM720/SM721

2D/3D Register Mask Format

31	30	29	28	27	26	25	24	23	22	21	20	19	18	17	16
0	1	DMA CONTROL		PCI OFFSET											
15	14	13	12	11	10	9	8	7	6	5	4	3	2	1	0
PCI OFFSET				DWORD COUNT											

- Bit 31:30** DMA Data Type
 00: Vertex data
01: 2D/3D registers/commands
 10: Host blit write data
 11: Low level engine (wait, flush, flip,...etc.)*
- Bit 29:28** DMA Control

x1: End of A DMA buffer

1x: End of A DMA block

Bit 27:12 PCI offset - 16 bits**Bit 11:0** Dword count - number of consecutive DW in the following DMA data

Host Blit Write Data Mask Format

31	30	29	28	27	26	25	24	23	22	21	20	19	18	17	16
1	0	DMA CONTROL		RESERVED											
15	14	13	12	11	10	9	8	7	6	5	4	3	2	1	0
RESERVED															

Bit 31:30 DMA Data Type
 00: Vertex data
 01: 2D/3D registers/commands
10: Host blit write data
 11: Low level engine (wait, flush, flip,...etc.)*

Bit 29:28 DMA Control
 x1: End of A DMA buffer
 1x: End of A DMA block

Bit 27:0 Reserved